

# US VIRGIN ISLANDS ENVIRONMENTAL PROTECTION HANDBOOK

2022 UPDATE

A GUIDE TO STORMWATER MANGEMENT STANDARDS AND CONTROL MEASURES



**PREPARED FOR**

VI DEPARTMENT OF PLANNING AND NATURAL RESOURCES  
US ENVIRONMENTAL PROTECTION AGENCY

**PREPARED BY**

HORSLEY WITTEN GROUP, INC.



## FORWARD

The Environmental Protection Handbook (EPH) is intended to guide engineers, designers, builders, and regulators on the criteria and practices for temporary and permanent stormwater management to comply with the Virgin Islands Environmental Protection Law, Title 12, Chapter 13 of the Virgin Islands Code and the corresponding Rules and Regulations. The EPH includes the island's first comprehensive set of stormwater management standards aimed at avoiding negative environmental impacts, addressing water quality and flooding concerns, and improving climate resiliency during land development and redevelopment activities. The EPH presents guidance on applying sustainable site design principles, selecting appropriate structural and non-structural stormwater control measures (SCMs), and designing and maintaining practices over time to ensure proper function. While homeowners and small residential lot development will benefit from using the techniques presented herein, some of the practices and standards are more applicable to larger projects.

The information presented here will be used by reviewing agencies to evaluate proposed erosion control plans, stormwater drainage plans, and unpaved road maintenance needs. Applicants can propose practices that are not included herein but will need to provide sufficient information to ensure compliance with stormwater standards.

This handbook does not address renewable energy, wastewater management, gut restoration, or shoreline stabilization techniques. Future volumes of the EPH may include these practices.

This manual has been supported by a grant from the U.S. Environmental Protection Agency's CWA Section 319 Program and supplemental funding provided by the NOAA Coral Reef Conservation Program service contracts DG133C-12-BA-0056 and EA133C-17-BA-0054 for Watershed Coordination, Protection, and Restoration to Control Land Based Sources of Pollution in the Caribbean and Pacific Islands. It is considered an update to the 2002 Environmental Protection Handbook published by the University of the Virgin Islands Cooperative Extension Service and retains much of the original material.

## REVISION HISTORY

Wright, J., J. Bernier, M. Montes, and M. Morales. 2002. *Virgin Islands Environmental Protection Handbook*. Third Revision. University of the Virgin Islands, Cooperative Extension Service. 302 pp.

Wright, J.A. 1995. *1995 Virgin Islands Environmental Protection Handbook*, Virgin Islands Nonpoint Source Pollution Control Committee, Virgin Islands Department of Planning and Natural Resources, St. Croix, U.S. Virgin Islands.

Virgin Islands Conservation District. 1976. *Virgin Islands Environmental Protection Handbook*, Kingshill, St. Croix, U.S. Virgin Islands.

## SUGGESTED CITATION

Horsley Witten Group. 2022. *Virgin Islands Environmental Protection Handbook: A Guide to Stormwater Management Standards and Control Measures*. Prepared for VI Department of Planning and Natural Resources, Division of Environmental Protection.

*Cover Photo: Coral Bay Community Council*

## ACKNOWLEDGEMENTS

The 2022 EPH update benefited significantly from previous efforts by the authors, agency staff, and local practitioners in the Virgin Islands that have been investigating watershed issues, observing the land development process, and demonstrating stormwater management techniques over the past few decades. The rainfall analyses and stormwater standards presented here were developed in 2015 in collaboration with the Stormwater Working Group, which, at the time, included contributions from the following individuals: Jean Pierre Oriol, Bevan Smith, Emanuel Liburd, Alexis Doward, Benjamin Keularts, Vernill Roberts, Syed Syedali, and Anita Nibbs (DPNR); John Green, Alan Fleming, and Vancito Gumbs (VIHFA); Carlos Tessitor (GEC); Bill McComb (CDR Maguire); Taylor Babb; Patricia Reed (CBCC); Anne Marie Hoffman (TNC); Kynoch Reale-Munroe (UVI); Julie Wright (USDA NRCS); and Marlon Hibbert, Rob Ferguson, and Lisamarie Carrubba (NOAA). The unpaved road standards are a new addition to this handbook that were not considered by the Stormwater Working Group but are based on the 2021 Unpaved Road Standards for Caribbean and Pacific Islands.

We appreciate the input of Sharon Coldren and Shiloh Moates from the Coral Bay Community Council and of additional DPNR staff as the EPH update was being drafted, including Pedro Nieves, Hilary Lohmann, and Emanuel Liburd. Special thanks to Julie Wright for maintaining electronic files from the 2002 Handbook and to Donna Somboonlakana at USEPA, Austin Callwood, Mary Stiehler, and Jedidah Morrell at DPNR for keeping the dream alive.

## DISCLAIMER

This publication was developed under Assistance Agreement No. C9-96286401, awarded by the U.S. Environmental Protection Agency to the Virgin Islands Department of Planning and Natural Resources. The views expressed in this document do not necessarily reflect those of the Agency. EPA does not endorse any products or commercial services mentioned in this publication.

# TABLE OF CONTENTS

<b>CHAPTER 1: INTRODUCTION.....</b>	<b>1-1</b>
1.1 PURPOSE.....	1-2
1.2 STORMWATER IMPACTS.....	1-2
Watershed Alterations.....	1-2
Erosion and Sedimentation.....	1-5
Increased Flooding.....	1-6
Water Quality Degradation.....	1-6
Infrastructure Damage.....	1-8
Ecological Impacts.....	1-8
Economic Impacts.....	1-9
1.3 MANAGEMENT OBJECTIVES.....	1-9
Low Impact Site Design.....	1-10
Erosion and Sedimentation Control.....	1-10
Green Stormwater Infrastructure.....	1-10
New Development, Redevelopment, & Retrofits.....	1-13
Social Equity.....	1-13
Climate Resiliency.....	1-15
Regulations and Permitting.....	1-17
1.4 HOW TO USE THE HANDBOOK.....	1-17
1.5 THE STORMWATER PLANNING PROCESS.....	1-18
<b>CHAPTER 2: STORMWATER STANDARDS.....</b>	<b>2-1</b>
2.1 STANDARDS FOR TEMPORARY EROSION AND SEDIMENT CONTROL.....	2-4
ESC-1 ESC Plan and Sequencing.....	2-4
ESC-2 Resource Protection.....	2-5
ESC-3 Clearing and Grading.....	2-6
ESC-4 Soil Stabilization.....	2-6
ESC-5 Slope Protection.....	2-7
ESC-6 Perimeter Controls.....	2-7
ESC-7 Settling Devices.....	2-7
ESC-8 Conveyance Structures.....	2-8
ESC-9 Education and Training.....	2-8
ESC-10 Practice Maintenance.....	2-9
ESC-11 Performance Accountability.....	2-9
2.2 POST-CONSTRUCTION STANDARDS FOR PERMANENT STORMWATER CONTROL.....	2-9
SW-1 No Unmanaged Runoff.....	2-10
SW-2 Runoff Reduction.....	2-11
SW-3 Water Quality.....	2-12
SW-4 Gut Protection.....	2-12
SW-5 Safe Conveyance.....	2-13
SW-6 Overbank Flooding.....	2-14
SW-7 Operation/Maintenance.....	2-14
SW-8 Pollution Prevention.....	2-15
SW-9 Pollutant Hotspots.....	2-15

	SW-10 Illicit Discharges .....	2-16
2.3	UNPAVED ROAD STANDARDS .....	2-16
	UR-1 Controlled Runoff .....	2-17
	UR-2 Upgradient Disconnection .....	2-17
	UR-3 Road Width .....	2-18
	UR-4 Surface Pitch .....	2-18
	UR-5 Unpaved Surface Restrictions .....	2-19
	UR-6 Reduced Surface Travel Times .....	2-19
	UR-7 Conveyances and Outlets .....	2-20
	UR-8 Surface Compaction .....	2-21
	UR-9 Stabilized Cut & Fill Slopes .....	2-21
	UR-10 Maintenance Agreements .....	2-21

**CHAPTER 3: SITE DESIGN & PLANNING STRATEGIES .....3-1**

3.1	GETTING TO KNOW YOUR SITE .....	3-2
	Watershed Context .....	3-2
	Environmental Justice .....	3-4
	Climate .....	3-4
	Soils .....	3-7
	Other Environmental Factor .....	3-12
	Contributing Drainage Areas .....	3-13
	Applicable Permits .....	3-14
3.2	RUNOFF REDUCTION USING LID .....	3-14
	Vegetated Open Space Preservation .....	3-16
	Soil Protection .....	3-17
	Multi-functional Landscaping .....	3-17
	Impervious Surface Diet .....	3-18
	Runoff Disconnection and Distribution .....	3-19
3.3	PLANNING FOR ROADS AND DRIVEWAYS .....	3-20
	Road Planning Principles .....	3-20
	Designing for Drainage .....	3-23
	Construction Planning .....	3-25
	A Commitment to Maintenance .....	3-26
3.4	GOOD HOUSEKEEPING PRACTICES .....	3-28
	Waste Disposal .....	3-28
	Material Management .....	3-29
	Spill Prevention and Response .....	3-30
3.5	OPERATIONS AND MAINTENANCE .....	3-30
	Operations and Maintenance Plans .....	3-31
	Functional System Components .....	3-31
	Inspections .....	3-33
	Scheduled and Corrective Maintenance .....	3-33
3.6	RETROFITS AND REDEVELOPMENT .....	3-34

<b>CHAPTER 4: EROSION AND SEDIMENT CONTROL PRACTICES FOR CONSTRUCTION .....</b>	<b>4-1</b>
4.1	SEDIMENT BARRIERS ..... 4-2
	Limits of Disturbance ..... 4-3
	Tree and Buffer Protection ..... 4-5
	Stabilized Construction Entrance ..... 4-7
	Brush Berms ..... 4-9
	Filter Socks ..... 4-10
	Silt Fencing ..... 4-12
	Turbidity Curtains ..... 4-17
4.2	STABILIZATION PRACTICES ..... 4-19
	Surface Roughening ..... 4-21
	Temporary and Permanent Seeding/Planting ..... 4-24
	Mulches ..... 4-31
	Erosion Control Mats and Blankets ..... 4-32
	Retaining Walls/Soil Bioengineering ..... 4-35
4.3	DIVERSION AND CONVEYANCE PRACTICES ..... 4-42
	Diversion Berms and Swales ..... 4-43
	Pipe Slope Drains ..... 4-45
	Check Dams ..... 4-47
	Lined Waterways ..... 4-50
	Temporary Stream/Gut Diversions and Isolation ..... 4-53
4.4	SEDIMENT TRAPPING DEVICES ..... 4-55
	Sediment Traps ..... 4-57
	Sediment Basins ..... 4-60
	Dewatering Devices ..... 4-65
4.5	INLET AND OUTLET PROTECTION PRACTICES ..... 4-70
	Inlet Protection ..... 4-71
	Rock Outlet Protection ..... 4-77
	Level Spreader ..... 4-84
4.6	UNPAVED ROAD PRACTICES ..... 4-86
	Grade Breaks ..... 4-88
	Broad-Based Dips ..... 4-89
	Cross Drains and Culverts ..... 4-93
	Waterbars ..... 4-96
	Turnouts ..... 4-99
	Geosynthetics ..... 4-100
	Surface Stabilizers ..... 4-103
<b>CHAPTER 5: POST-CONSTRUCTION STORMWATER PRACTICES.....</b>	<b>5-1</b>
5.1	PRACTICE SELECTION SUMMARY ..... 5-3
5.2	RUNOFF REDUCTION PRACTICES ..... 5-7
	Rainwater Harvesting ..... 5-8
	Green Roofs ..... 5-17
	Infiltration Practices ..... 5-22
5.3	WATER QUALITY TREATMENT PRACTICES ..... 5-41
	Filters ..... 5-41
	Constructed Wetlands ..... 5-52

5.4	PRETREATMENT PRACTICES .....	5-63
	Grass Channels .....	5-63
	Sediment Forebay .....	5-66
	Deep Sump Catch basin .....	5-67
	Proprietary Devices.....	5-70
5.5	LARGE STORAGE PRACTICES.....	5-72
	Stormwater Basins.....	5-72
	Underground Storage Devices.....	5-79

**REFERENCES.....R-1**

**APPENDICES**

- APPENDIX A: STORMWATER STANDARDS CHECKLIST
- APPENDIX B: PRECIPITATION INFORMATION
- APPENDIX C: SAMPLE OPERATIONS & MAINTENANCE TEMPLATES





# 1

# INTRODUCTION

<b>1.1 PURPOSE.....</b>	<b>1-2</b>
<b>1.2 STORMWATER IMPACTS.....</b>	<b>1-2</b>
Watershed Alterations .....	1-2
Erosion and Sedimentation.....	1-5
Increased Flooding.....	1-6
Water Quality Degradation.....	1-6
Infrastructure Damage.....	1-8
Ecological Impacts.....	1-8
Economic Impacts.....	1-9
<b>1.3 MANAGEMENT OBJECTIVES .....</b>	<b>1-9</b>
Low Impact Site Design.....	1-10
Erosion and Sediment Control.....	1-10
Green Stormwater Infrastructure.....	1-10
New Development, Redevelopment, & Retrofits.....	1-13
Social Equity.....	1-13
Climate Resiliency.....	1-14
Regulations and Permitting .....	1-16
<b>1.4 HOW TO USE THIS HANDBOOK .....</b>	<b>1-17</b>
<b>1.5 THE STORMWATER PLANNING PROCESS .....</b>	<b>1-18</b>

The prevention and control of nonpoint pollution from development activities and other sources in coastal areas requires comprehensive solutions to protect and enhance coastal water quality. The 2022 Virgin Islands Environmental Protection Handbook (EPH) supersedes previous versions of the Handbook (2002, 1995, and 1976) and includes new standards to manage stormwater runoff at construction sites, developed sites, and unpaved roads.

Over the last 20 years, additional scientific evidence has emerged regarding the negative impacts of stormwater runoff from development in the Caribbean region. There is general agreement by engineers and island managers on the effectiveness and limitations of stormwater control practices. The flood control focus that was the emphasis of past stormwater management approaches has evolved into a strategy focused on reducing the amount of runoff generated, stabilizing exposed soils immediately, and using green stormwater infrastructure to mimic natural hydrologic processes and enhance infrastructure resiliency. New federal and territorial rules and regulations governing stormwater discharges have expanded in response to the growing number of receiving waters impaired by stormwater runoff, the addition of coral species to the endangered species list, climate change, and environmental justice. This handbook was updated using the most current information available regarding practices to control or prevent stormwater pollution in the Virgin Islands.

## 1.1 PURPOSE

The 2022 EPH is intended for use as a guide to the reader by identifying appropriate standards, practices, and procedures that should be used in the development process to comply with the Virgin Islands Environmental Protection Legislation, Title 12, Chapter 13 of the Virgin Islands Code and the corresponding Virgin Islands Rules and Regulations. It is designed to assist, developers, architects, engineers, and builders implement an effective erosion and sediment control plan for construction sites, a post-construction stormwater management plan, and drainage plans for unpaved roads. This handbook provides information on standards for the design and maintenance of temporary and permanent stormwater measures to prevent or reduce the negative impacts of stormwater on a site. It also describes structural practices that can be used and how to select, size, and design them.



*Unmanaged stormwater runoff from construction sites, impervious surfaces, and unpaved roads can have a negative impact on the environment, infrastructure, and economy. Sediment plumes like the one pictured in Coral Bay are a visual indicator of inadequate stormwater controls and the resulting harm to coastal resources (photo credit: Coral Bay Community Council, 2007).*

Careful consideration must be given to selecting the most appropriate control measures based on site-specific conditions, and on properly installing the controls in a timely manner. The drawings presented in this Handbook are examples and should be reviewed by a licensed engineer and/or architect before construction.

## 1.2 STORMWATER IMPACTS

Stormwater runoff is the portion of precipitation that drains off the land's surface. Rainfall amount and intensity, land cover, slopes, and soils are all critical factors that will impact the volume and speed of runoff that is generated during a storm. Surface runoff can lead to the erosion of exposed soils and guts, flood streets, and pick up and transport pollutants. Depending on the watershed, unmanaged stormwater can lead to water quality concerns that can impact both humans and aquatic biota.

### Watershed Alterations

The natural hydrologic cycle describes how water moves through the environment. Rain can follow several paths depending on where it falls including infiltration into the ground, storage in a surface feature such as a pond or ocean, transpiration (uptake by vegetation), evaporation, or surface runoff (**Figure 1.1**). Infiltration into groundwater can be critical for

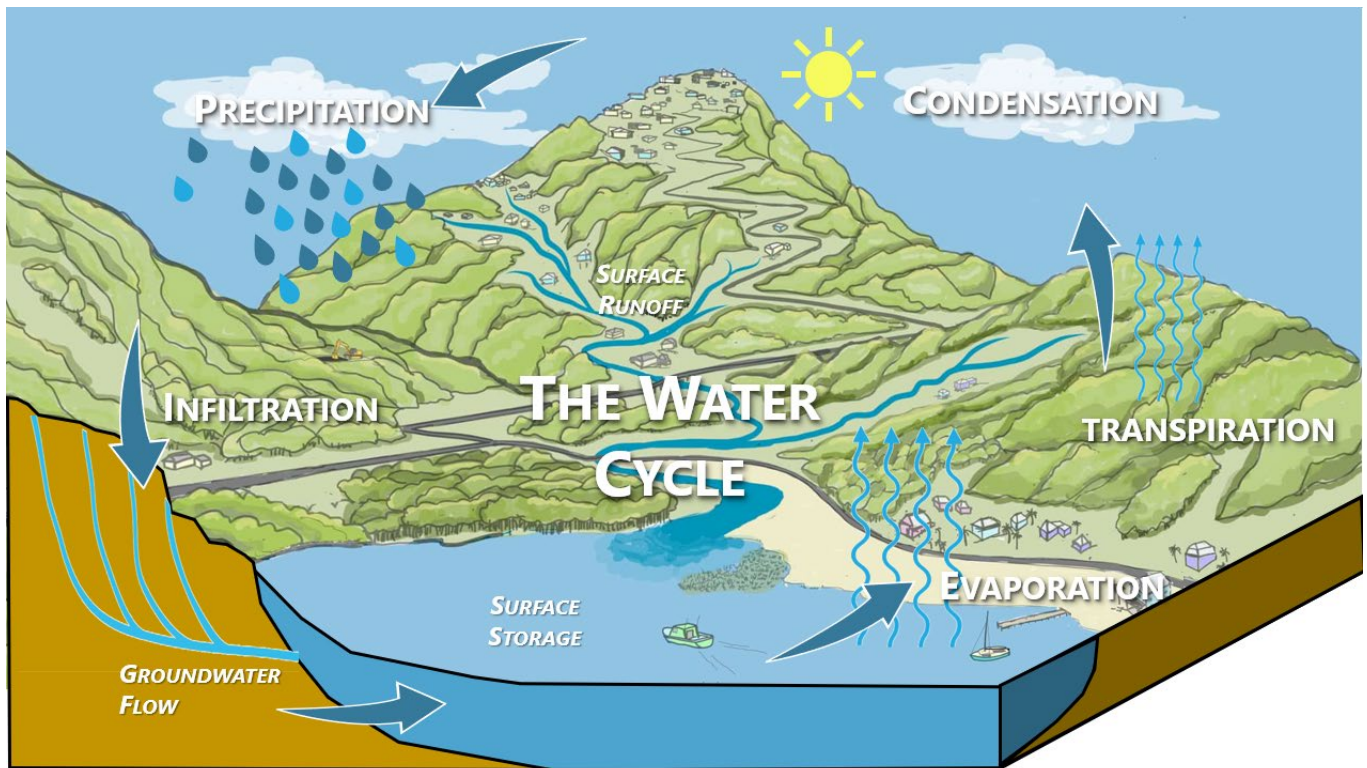

Figure 1.1 The hydrologic cycle (adaptation of graphic created by the Coral Bay Community Council)

islands that rely on aquifers for drinking water. Evaporation from surface waters and evapo-transpiration from vegetation return water to the atmosphere, where it condenses and turns back into rain.

Watersheds respond negatively when the natural hydrology is altered by human activities. A watershed is broadly defined as the area of land that drains to a particular waterbody when it rains (**Figure 1.2**). Watershed boundaries are primarily based on topography but can be adjusted to account for groundwater flows and manmade pipe networks. In a natural, vegetated watershed, rainfall can seep into the soil, be absorbed by vegetation, or temporarily be held in natural depressions until it evaporates or drains to the ocean. Surface runoff is slowed by plants and conveyed non-erosively through guts that were naturally formed to handle most rainfall events without eroding. Plant foliage also intercepts raindrops, reducing the detachment and erosion of soil particles through raindrop splashing.

During development, however, vegetation and soils are stripped from the land and the surface is compacted or built upon, further reducing infiltration

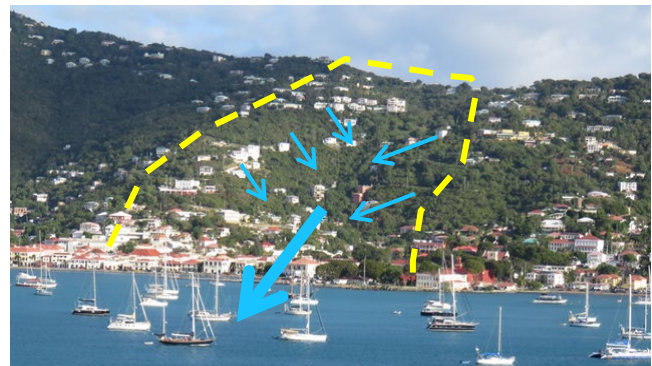
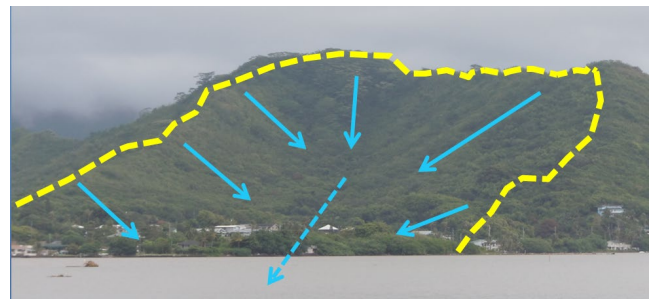

Figure 1.2 The hydrology of undeveloped (top) and urbanized (bottom) watersheds is significantly different. Urban watersheds experience increased flooding frequencies, more water quality problems, reduced groundwater recharge, and declining biological health. This trend corresponds directly with increased surface runoff generated by impervious cover and the loss of vegetation and native soils.

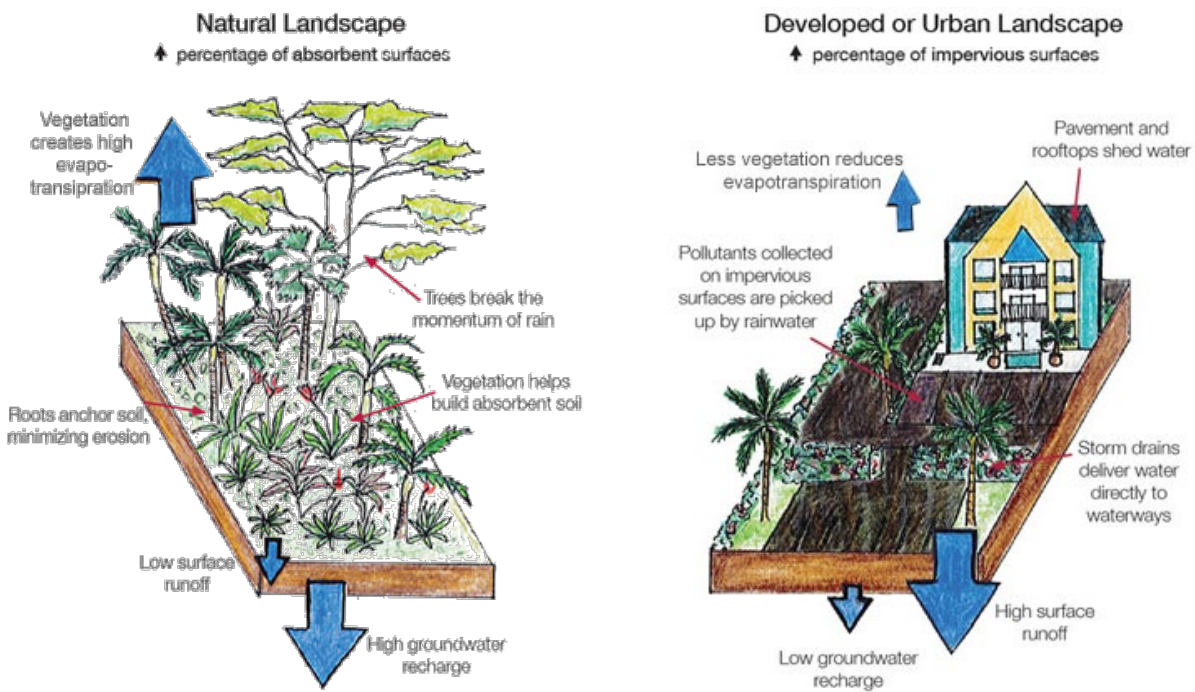

Figure 1.3. Hydrologic changes associated with urbanization can result in microclimate change in small, island ecosystems, such as the Virgin Islands (adapted from Coral Reef Alliance).

and plant uptake. As such, the amount of rain converted to surface runoff increases disproportionately (**Figure 1.3**). This change can lead to severe erosion and more frequent flooding where surface storage features and drainage systems do not have enough capacity to handle excess runoff. Eroding roadbeds and the cutting of slopes can cause costly property damage. Sediment and other pollutants carried from construction sites, roads, and other impervious surfaces can clog drainage inlets and culverts or be deposited in guts, downhill properties, or in ponds and coastal waters. Large-scale removal of vegetation reduces wildlife habitat, promotes landslides, and threatens biological diversity. Construction along ridge lines and in guts (intermittent streams) is rapidly depleting moist forest habitat and changing microclimates in the territory.

Individual land clearing and development decisions may not have a measurable effect on the hydrologic cycle; however, collectively, these land use changes can be significant. In fact, it is widely accepted that a watershed with approximately 10% impervious cover will show signs of flooding, poor water quality, and biological degradation. As the conversion of undeveloped lands to urban uses continues in the VI, negative trends in watershed health seen today will continue (**Figure 1.4**).

The beauty and health of the Virgin Islands' environment is vital to the health and well-being of all Virgin Islanders. Many residents enjoy the beaches and coastal waters for swimming, bathing, snorkeling, diving, sailing, and fishing. The Virgin Islands fishing industry depends upon healthy coastal waters and reefs for its livelihood. Many residents also use native plants for cultural or medicinal purposes. To provide fresh water to the growing population, and to ensure healthy terrestrial ecosystems, it is critical to retain as much rainwater as possible within the ground, in guts and in other surface water bodies.

Coastal water quality has been steadily deteriorating due to the influx of sediment, sewage and other pollutants. However, these services and environmental health, in general, are often considered to be secondary to urban growth and development. Unsightly, raw excavation scars remain long after land development has been completed. The health of the coral reefs is correspondingly declining. Many native plants and animals have become rare, threatened or endangered. This degradation is a long-term threat to the Virgin Islands economy, especially since that economy is dependent upon its environmental health and beauty to attract tourism, the largest industry.

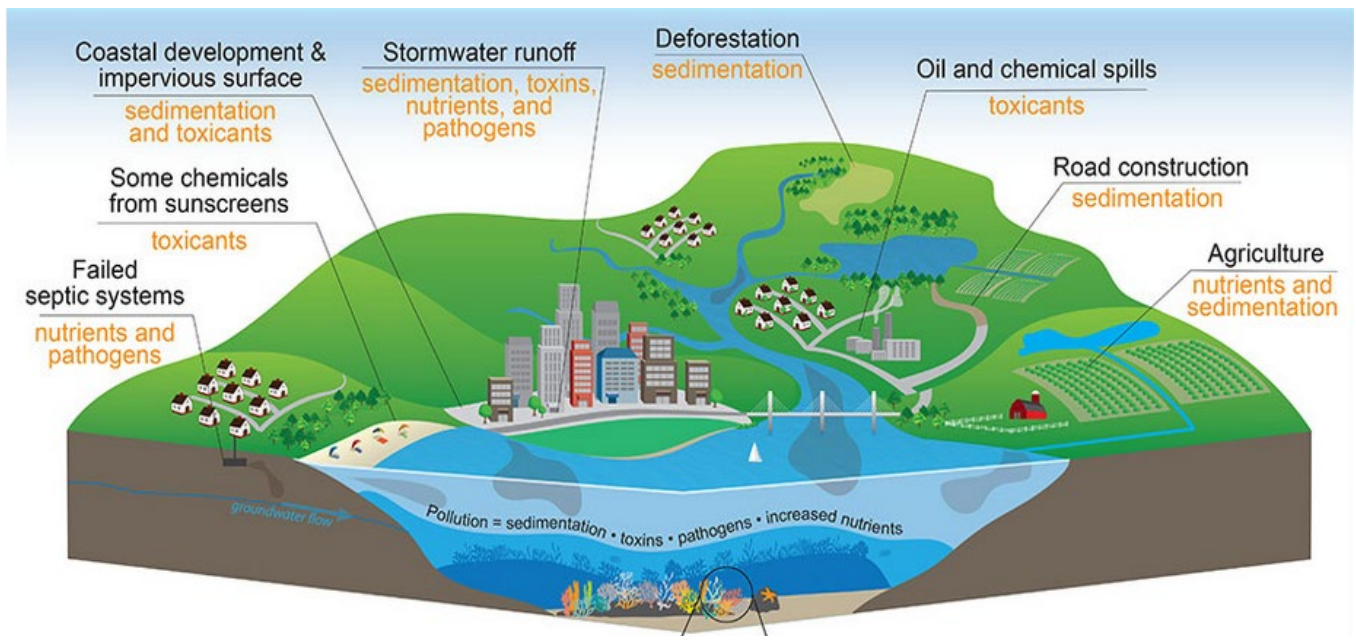

Figure 1.4. Coral watersheds are susceptible to a diversity of land-based sources of pollution. The focus of the 2022 EPH Vol. 1 Stormwater Standards and Design is on managing the impacts of coastal development and impervious surfaces, deforestation, stormwater runoff, and road construction (info graphic from NOAA, 2021).

### Erosion and Sedimentation

Erosion is the loosening and removal of soil particles from the land surface by running water. There are many different types of erosion that get progressively more severe as concentrated flows grow bigger and faster: raindrop, sheet, rill, gully, and channel erosion. The primary factors affecting erosion are rainfall intensity and frequency, soil characteristics, vegetative and other surface cover, slope, climate, and aspect (i.e., degree of exposure to sun and trade winds). Rainfall intensity and slope steepness are the most significant factors affecting erosion (Figure 1.5). Unlike flat terrain, water concentrates and travels faster down steep slopes. Sediments on cut and fill slopes are particularly vulnerable to erosion. Heavy rainfall can exacerbate erosion and sediment loss. If possible, avoid exposing surfaces during the rainy season. Soil texture and structure can also affect infiltration capacity, soil detachment, and transport.

While land erosion is a natural process, manmade changes to the landscape often trigger more rapid rates of erosion and sediment transport, such as unpaved roads that serve as drainageways; gut scouring and bank erosion due to high runoff velocities; exposed soils from grazing and agriculture; and land clearing for construction. Studies in the USVI and Puerto Rico have shown that unpaved roads can

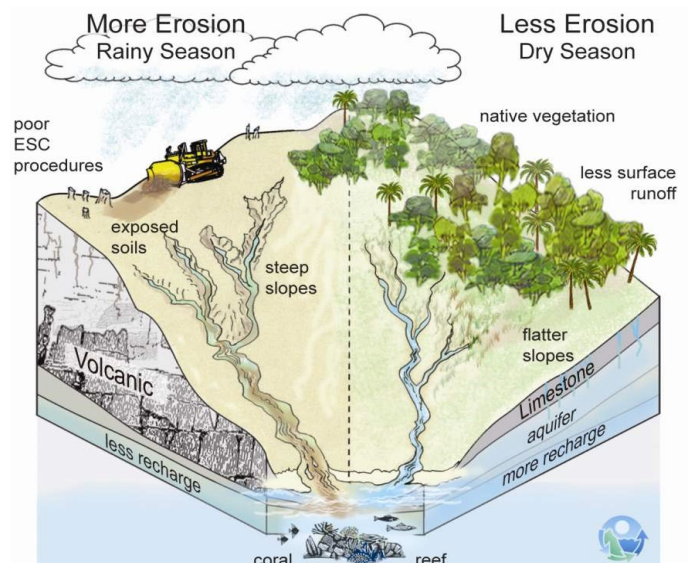

Figure 1.5. Factors contributing to soil erosion at construction sites in a coral watershed (HW, 2009).

generate sediment at a rate of up to four orders of magnitude greater than undisturbed lands (Ramos-Scharrón and MacDonald, 2005; Ramos-Scharrón and LaFevor, 2016). Erosion rates from unpaved roads in Culebra, Puerto Rico was estimated to contribute nearly 400 metric tons of sediment delivery to the coast per year (Ramos-Scharrón and Hernandez, 2015). Bare soil from unmanaged construction sites can have erosion rates of 80-100 times greater than vegetated

land. Plants help to reduce erosion by intercepting rainfall and reducing raindrop energy, slowing runoff velocity, holding soil in place with roots, and improving soil porosity. Over time, runoff will deepen rills and cut gullies on land surfaces and eroded sediment can be transported directly to wetlands and marine waters, which can be disastrous for aquatic ecosystems.

Finally, improperly installed or maintained ESC practices can lead to significant erosion and sedimentation. If proper ESC measures are not planned and implemented, the environment, human health, public safety, project costs, and the local economy can all be impacted. Preventing erosion and containing sediment is particularly important in the Virgin Islands because of the potential impacts on sensitive coral reef and sea grass habitats which are important for fisheries, tourism, and ecological sustainability.

### Increased Flooding

Impervious surfaces can generate higher volumes and speed (rate or velocity) of runoff than undeveloped lands that can lead to increased frequency and severity of flooding (**Figure 1.6**). The hydrologic changes resulting from urbanization include:

- Increased peak runoff discharges two to five times pre-development levels;
- Increased volume of stormwater runoff produced by storms (a moderately developed watershed can produce 50% more runoff than a forested watershed during the same storm);
- Greater runoff velocity during storms;
- Reduced water levels in soils, guts, and aquifers due to the reduced level of infiltration in the watershed; and
- Collapse of roadways and contribution to the formation of sinkholes.

Small storms can be controlled with stormwater facilities in many cases, but the management of larger storms (hurricanes and 100-yr storms) is more about providing “safe” conveyance to protect people, property, and infrastructure. Managing more surface runoff often involves investments in road drainage improvements, culvert replacements, and the modification of existing drainage systems to accommodate larger flows while protecting road infrastructure and minimizing channel erosion.

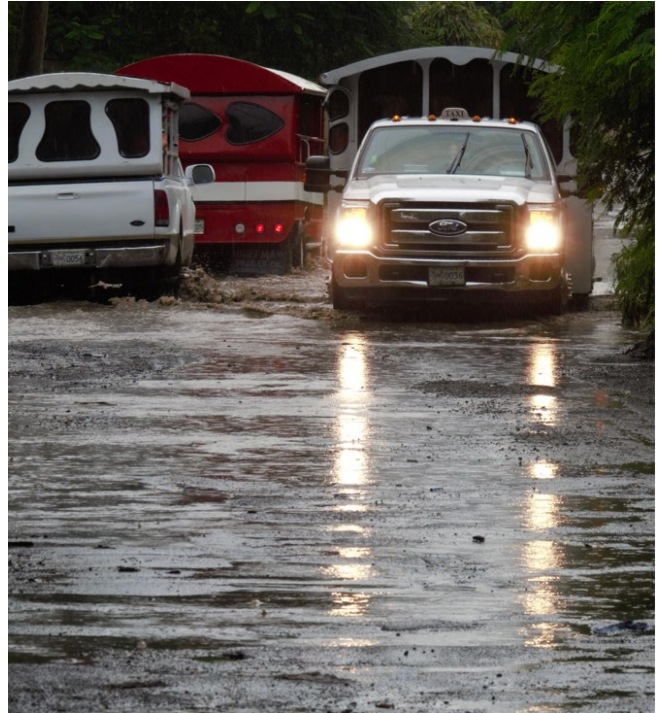

*Figure 1.6. Flooding in Smith Bay is a recurring issue due to lack of drainage controls, development density, and alterations to the natural system of guts and wetlands.*

### Water Quality Degradation

Pollutant loading to receiving waters increases dramatically both during and after development. During construction, soils are exposed and large amounts of sediment, along with attached nutrients and other pollutants, can run off into surface waters if proper erosion and sedimentation controls are not used. Once construction is complete, pollutants accumulate rapidly on impervious surfaces and are washed off during storm events if not managed properly with pollution prevention measures and stormwater management practices.

The primary pollutant carried by stormwater runoff in the VI is sediment, but many other pollutants can be transported to coastal waters by stormwater runoff such as excess nutrients, harmful bacteria and viruses, oil and grease, heavy metals, trash, and other contaminants. The sources of many stormwater-related pollutants include exposed soils, atmospheric deposition, fertilizers, animal waste, sanitary sewer overflows, and vehicle emissions, brake pads, etc. Some pollutants, such as nutrients, heavy metals, and hydrocarbons, also travel attached to sediments and organic material. The overall effect of development can

result in a 10-fold increase in pollutant loads entering surface waters.

According to the 2020 USVI Integrated Waters Monitoring and Assessment Report, almost half of the 305(b) assessment units are classified as impaired (category 4 and 5) for water quality, primarily for bacteria, turbidity, or dissolved oxygen. These impaired waters cover most of the shoreline along St. Thomas and St. John and over 1/3 of the shoreline in St. Croix.

### *Sediment*

Sediment is the most prevalent pollutant, by volume, polluting surface waters in the U.S. Virgin Islands. Uncontrolled construction site sediment loads have been reported to average 35 to 45 tons/acre/year in the continental United States (Novotny and Chesters, 1981). Studies in Puerto Rico have shown that unpaved roads can generate sediment at a rate of up to four orders of magnitude greater than undisturbed lands (Ramos-Scharrón and MacDonald, 2005). A 1986 study of erosion rates on St. Thomas and St. Croix estimated erosion from a disturbed unpaved road site to be 591 tons/acre/year (Wernicke, Seymour and Mangold, 1986). In the Fish Bay watershed on St. John, soil loss from dirt roads was estimated between 100 to 600 tons/yr (MacDonald, et. al., 1997; Sampson, 1997).

Sediment has many short- and long-term harmful impacts on aquatic ecosystems. These include increased turbidity, reduced light penetration (which inhibits coral and seagrass growth), reduced prey capture for sight-feeding fish, clogging of gills and filters in fish and shellfish, reduced spawning and juvenile fish survival, and the decline of commercial and recreational fishing success. Heavy sediment deposition in coastal waters smothers seagrass beds and coral reefs, increases sedimentation of channels and harbors (requiring more frequent dredging), changes bottom composition, and leads to loss of use for recreational purposes (such as swimming and snorkeling). Additional chronic effects may occur where there are sediments rich in clay or organic matter, as is frequently the case in the Virgin Islands. Heavy metals and other toxic pollutants can tightly attach to soil particles. When these contaminated sediments settle to the bottoms of ponds, bays, channels and lagoons, they present a continued risk to aquatic and benthic life (organisms that live in the sediments at the bottom of bays, estuaries, and other

waterbodies), especially when the sediments are disturbed and resuspended (U.S. EPA, 1993). Wave-induced resuspension of sediment in coastal waters may also have negative impacts on reefs and seagrass beds (Gray et al., 2012 and Sears, 2015).

### *Nutrients*

Excess levels of nutrients (particularly nitrogen and phosphorus) that runoff to coastal waters cause an imbalance in the natural nutrient cycle, leading to unwanted and excessive algae growth. This process is called eutrophication (Arms and Camp, 1988; Dunne and Leopold, 1978; Miller, 1982). Excessive algae growth uses up dissolved oxygen in the water and results in decreased fish, coral, and seagrass populations, and in extreme cases, can result in fish kills and widespread destruction of benthic habitats. In addition, low dissolved oxygen has been associated with reduced resistance to disease, lower reproductive rates, and increased susceptibility of aquatic animals to toxic substances. Algal blooms can cause discoloration and odors, cover water surfaces depriving aquatic organisms of light, and clog waterways. Surface algal scum and the release of toxins from sediment may also occur. Research is linking excess nutrient pollution with increased coral diseases such as yellow band disease, possibly due to nutrient utilization by the pathogens thought to cause the disease (Bruno et al., 2003). The relationship between nutrients and coral pathogens provides another reason for tropical watershed managers to be concerned about eutrophication and sedimentation derived from land-based sources of pollution.

### *Bacteria, Viruses and Other Pathogens*

Sources of bacteria include residents, tourists, wildlife, domestic animals and wildlife, wastewater systems, boat waste disposal, dumpster leachate, and stormwater runoff from developed lands (Pandey et al., 2014). Stormwater runoff from residential, commercial, and industrial areas usually contains levels of bacteria and other harmful (pathogenic) organisms (viruses, parasites) that exceed public health standards for water-contact recreation or seafood consumption. The presence of pathogens in runoff may result in beach closings to avoid contact recreation due to public health hazards, as well as to warn of contaminated fish and shellfish. In the Virgin Islands, beach closures frequently occur due to sewage bypasses. However, as more stringent water quality monitoring is put in place,

it is very likely that more beach closures will occur due to contamination by bacteria, viruses and other pathogens. It is worth noting that coral pathogens connected to land-based sources of pollution are a significant threat to the remaining coral populations in the region. Terrestrial pathogens, for example, may potentially cause disease in sea fans and stony corals (Thomas & Devine, 2005).

### *Petroleum Hydrocarbons (Oil and Grease)*

Most of the oil, grease and other petroleum hydrocarbon pollutants found in stormwater runoff come from car and truck engines that leak oil and other fluids. Therefore, hydrocarbon levels are highest in stormwater runoff from parking lots, roads, and gas stations. Some do-it-yourself auto mechanics also dump used oil directly on the ground, in guts, or into storm drains. Petroleum-based hydrocarbon levels in surface waters are often high enough to kill aquatic organisms. Oil and grease contain a wide variety of hydrocarbon compounds. Some of these are known to be toxic to aquatic life at low concentrations, and many are human carcinogens. Hydrocarbons also tend to collect in bottom sediments where they may persist for long periods of time and result in adverse impacts to benthic communities. Waterbodies with poor circulation (such as enclosed marinas) are particularly susceptible to this phenomenon.

### *Heavy Metals and Toxic Substances*

Heavy metals and other toxic materials found in stormwater runoff are of concern because of their poisonous effects on aquatic life and their potential to contaminate ground water. Copper, lead, and zinc are the most common metals found in stormwater runoff (many come from trucks and cars). A large amount of the metals present in stormwater runoff are attached to sediment. Metals and toxic compounds that enter coastal waters can accumulate in the tissues of fish and shellfish, harming human health.

### **Infrastructure Damage**

Increased peak flows can lead to backups, scour, and failure of stormwater facilities, culverts, roadbeds, and other hard infrastructure. Sediment laden discharge can clog downstream drainage infrastructure (e.g., drain inlets, culverts, and outfalls) that may lead to flooding of public roadways and adjacent properties and create unsafe pedestrian and traffic conditions. Cleaning out these systems can be costly, not only

from a labor and equipment perspective, but it can result in negative publicity for the construction company. Sedimentation can reduce the storage capacity of permanent stormwater ponding basins, fill farm ponds, reduce the flood storage functions of wetlands, and fill in conveyance ditches and swales. If sediment is discharged into a surface drinking water supply, such as a reservoir, it can also result in increased filtering costs.

On high-gradient islands in the tropics, erosion of unpaved roads can transport sediment into coastal waters and onto paved roads, clogging drainage infrastructure and becoming a public safety concern. Rutted and muddy road surfaces can render unpaved roads impassable, and when poorly repaired, can lead to increased maintenance frequency. In some watersheds, unpaved roads may account for more than half of the road network and most of the watershed-derived sediment loads to marine waters. Most of these are secondary access roads or driveways that are built and maintained by property owners with little municipal oversight. Where private roads require permits, or when publicly owned roads are constructed, there are often no regulations governing road layout, design, or drainage criteria.

### **Ecological Impacts**

Increased pollutant loads associated with watershed development has caused negative and sometimes irreversible damage to coral reefs, one of the most threatened ecosystems in the Caribbean, as well as the health of sea grasses, mangroves, and other highly valued coastal ecosystems. The most significant impacts are a reduction in water quality and loss of spawning, nursery, and foraging habitat for many ecologically and commercially important fish and invertebrate species. Sediment and organic particulate matter can increase turbidity, which is the amount of suspended particles in the water. Turbid water reduces the amount of light that can reach coral and seagrass, which rely on sunlight for photosynthesis presenting a major threat to reef health (Campbell, 2017). Increased turbidity can also reduce visibility for animals to feed and avoid predators and has been linked to reduced reproduction success.

Coral bleaching and disease triggered by other stressors (such as temperature shifts or pathogens) can be more problematic when poor water quality reduces the resiliency of coral populations to bounce back



from these events—increasing coral mortality rates. **Figure 1.7** shows results from two studies correlating reductions in coral populations and increases in macroalgae and coral bleaching as turbidity increases.

Increased erosion associated with the unpaved road network and land development in the Coral Bay watershed over the last 30 years, for example, has reduced the Bay’s ability to function as a thriving marine habitat (CBCC, 2021). Similar impacts on habitat and biological communities can be seen in

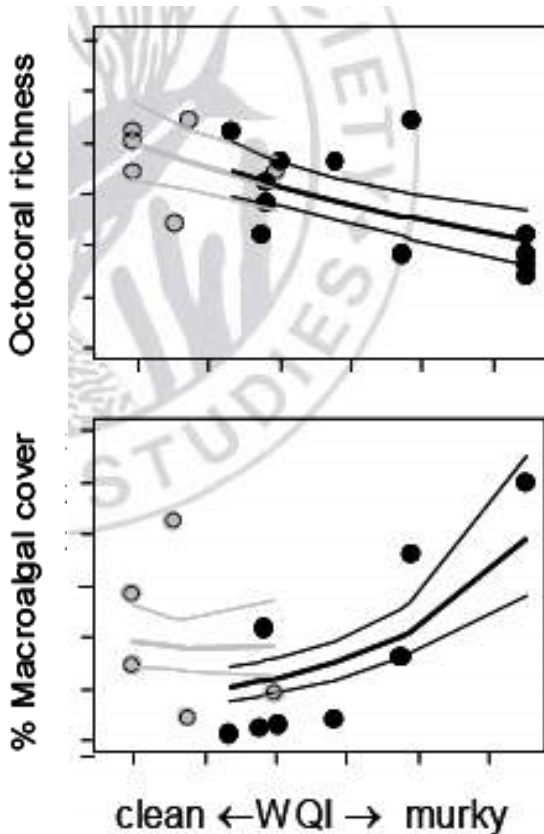
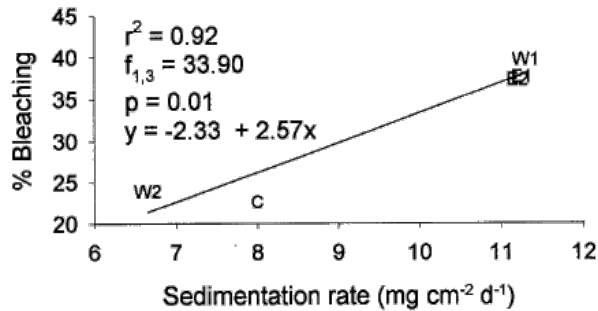

Figure 1.7 Top graph shows increase in %coral bleaching as sedimentation rate increases near construction sites in the US Virgin Islands (Nemeth and Nowlis, 2001). Middle and bottom graphs show decline in coral richness and increase in algal cover as turbidity increases (from Fabricus and De’ath, 2004).

guts and in freshwater ponds and wetlands. On land, the loss of sediment from a site may also correspond to loss of topsoil, which is a valuable component of terrestrial habitats.

### Economic Impacts

Private and commercial recreational uses, tourism, and subsistence fishing are all at risk from stormwater impacts on receiving waters. Beaches and nearshore environments contribute millions of dollars annually to the local economy from visitors and residents alike. When sediment-laden water reaches the coast, fish populations can decline, which can have a negative impact on the fishing industry for both locals and tourists. Fewer tourists may visit an area if sediment plumes at the coast look unsightly, beaches are closed due to pollution, or reefs are degraded which reduce their attraction to divers and snorkelers.

When the overall reef structure fails, there is the potential for higher wave energy and increased shoreline erosion. The USGS estimated the value of flood protection benefits in the form of averted damages to property and economic activities provided by coral reefs for all US coastal communities as being close to \$2B U.S. dollars per year and \$47M/yr. for the USVI specifically (Storlazzi, et al., 2019). A different economic analysis estimated total ecosystem services in the U.S. Virgin Islands was estimated at \$187M per year reflecting the value of tourism, recreation, real estate, coastal protection, and fishing (Van Beukering et al., 2011).

Negative impacts on water quality or flooding due to offsite runoff may also violate water quality standards, which can result in fines, clean-up requirements, and construction delays.

## 1.3 MANAGEMENT OBJECTIVES

Minimizing the impacts of stormwater requires a commitment to better runoff management at the watershed and individual site scale. There are several objectives to be achieved with stormwater management planning: 1) minimizing the amount of runoff that will be generated at the initial design stage; 2) preventing erosion and sedimentation; 3) using green infrastructure as the preferred approach to post-construction practices; 4) finding opportunities to enhance social equity; and 5) improving climate resiliency.

## Low Impact Site Design

Stormwater management begins at the planning stage with the recognition that land is a limited resource and that development decisions have consequences on watershed health. Proper planning provides for the informed use of soil, water, plants, and other natural resources. Strategies for environmental site design or low impact design (LID) are described in Chapter 3 and include the identification of site constraints and the intentional design of site layouts to be protective of the natural hydrologic features and judicious in the addition of new impervious cover. Site layout should take into consideration multi-functional landscaping, pollution prevention, and opportunities for watershed stewardship and restoration, where possible. Fully embracing this approach will require capitalizing on aspects of island culture that lend themselves to LID, overcoming physical and regulatory challenges unique to island settings:

- Trees provide shade, are a carbon sink, hold the soil in place, and offer habitat to wildlife; why not work around them where we can?
- Paving is expensive and native soil is valuable, so minimizing site disturbance and the use of impervious cover has an economic benefit.
- Freshwater is precious, droughts are frequent, and cisterns are common practice; therefore, reusing rain on site makes a lot of sense.
- Stormwater practice performance and the climate are both unpredictable, so distributing smaller practices throughout the site rather than relying on one big pond at the bottom of the hill builds redundancy.
- Space is a premium, so integrating landscaping with hydrologic objectives is a win/win.
- Evapotranspiration rates are high and vegetation growth rates are fast, making plants a big component of the stormwater plan.

## Erosion and Sediment Control

Fortunately, erosion and sedimentation can be effectively controlled on construction sites and unpaved roads using simple methods at minimal cost. Installation of a combination of the proper erosion and sediment control (ESC) practices can significantly reduce sedimentation from construction sites in the mainland US (**Figure 1.8**). The various practices have been grouped into three broad categories based on function, though there may be some overlap:

Effect of Erosion and Sediment Control Measures On Suspended Sediment Concentrations From Piedmont Construction Sites

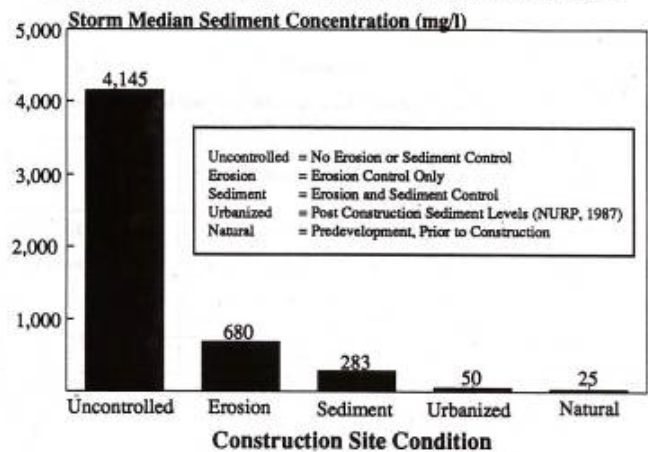

Figure 1.8. Effectiveness of erosion and sediment control practices at construction sites (adapted from Schueler and Lugbill, 1990)

*Erosion Prevention*—practices used to keep exposed soil in place and to keep it stabilized over the duration of the site work. Proper ESC begins with good planning to limit the amount of exposed soils on site and, thus, reduce the potential for erosion. Erosion control measures include construction phasing, limited clearing and grading, tree protection, and temporary and permanent stabilization, such as using erosion control blankets or hydroseeding.

*Sediment Trapping*—once erosion has occurred, mobilized sediment needs to be kept on site. Practices to prevent sediment from leaving a site include sediment barriers (silt fences and construction entrances), sediment trapping devices, dewatering, and dust control.

*Conveyance Mechanisms*—equally important are the practices used to move water around the site safely and without causing additional erosion. These include berms and swales, pipe-slope drains, check dams, and inlet/outlet protection devices.

ESC practices for construction sites and for improving drainage on unpaved roads are detailed in Chapters 4 and 6, respectively.

## Green Stormwater Infrastructure

Green infrastructure filters and absorbs stormwater where it falls. In 2019, Congress enacted the [Water Infrastructure Improvement Act](#), which defines green

infrastructure as "the range of measures that use plant or soil systems, permeable pavement or other permeable surfaces or substrates, stormwater harvest and reuse, or landscaping to store, infiltrate, or evaporate/transpire stormwater and reduce flows to sewer systems or to surface waters." Unlike conventional stormwater management designed primarily to control flooding and peak flow, GSI mimics the natural water cycle and is an effective, economical approach that enhances community safety and quality of life. Green infrastructure "integrates the natural environment and engineered systems to clean runoff, conserve ecosystem values and functions, and provide a variety of benefits to both people and wildlife" (American Rivers, 2022).

An important objective of GSI is to reduce stormwater volume, which improves water quality by reducing pollutant loads, stream bank erosion, and sedimentation. When employed as part of a larger-

scale stormwater management system, it reduces the volume of stormwater that requires conveyance and treatment through conventional means, such as detention ponds (Tetra Tech, 2015). GSI includes infiltration practices, bioretention/rain gardens, tree trenches, vegetated swales, permeable pavers, green roofs, and cisterns, and other devices described in detail in Chapter 5. Applying GI means distributing smaller practices around the site (e.g., integrate into landscaping, parking area, and rooftops); using volume reducing practices to promote infiltration, reuse, or evapotranspiration, then using vegetation and/or engineered media to clean runoff prior to any off-site discharge; and finally selecting storage practices if needed (**Figure 1-9**).

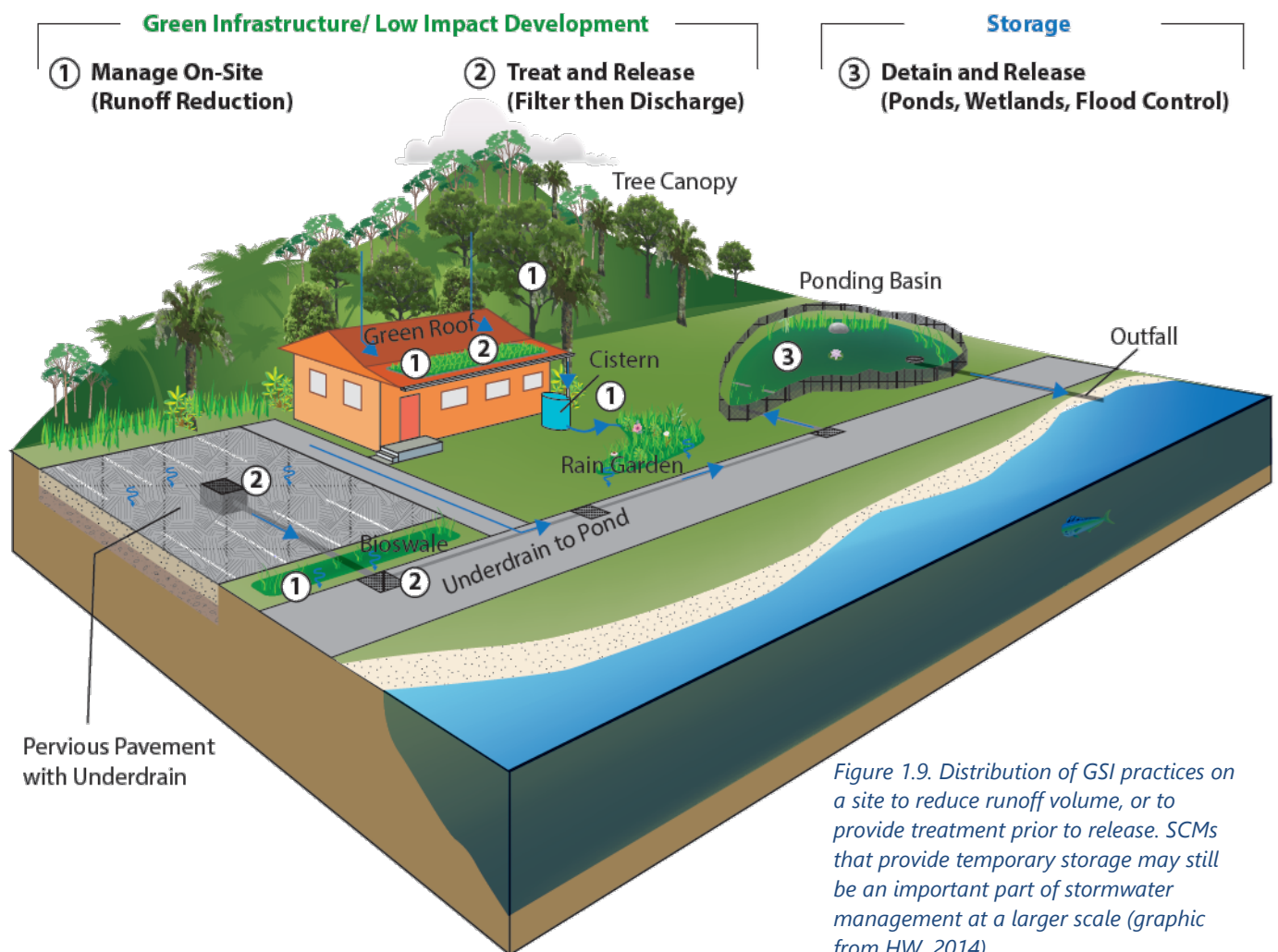

**Figure 1.10** is a representative hydrograph illustrating why stormwater management objectives have evolved over time. Comparing the runoff hydrograph between a natural, undeveloped site (green) and a developed site (red) shows a significant increase in the amount of runoff (area under the curve) and the speed at which the peak flows occur during a rain event. The use of detention ponds (black curve) helps reduce the peak flow but extends the length of time that large volumes of stormwater are released, causing downstream erosion. The GSI approach (blue) reduces total runoff volumes and peak flows and better mimics the natural condition, which is needed to maintain watershed health, meet climate challenges, and invest in nature-starved communities.

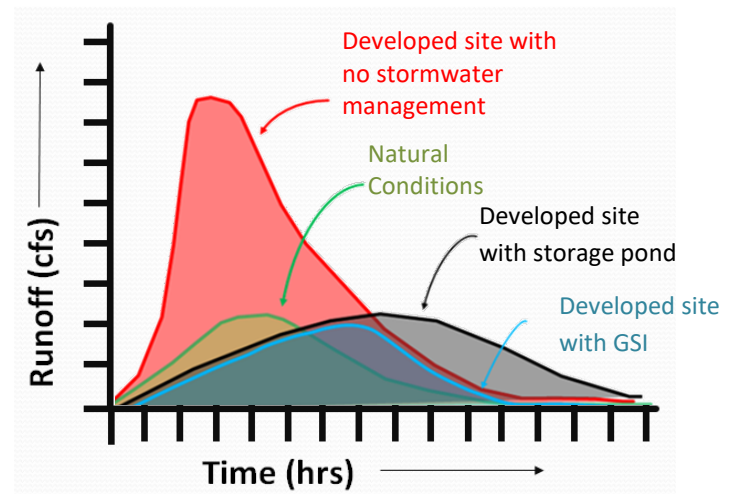

Figure 1.10. Hydrograph illustrating how the green infrastructure approach better mimics runoff from natural conditions (HW, 2014).

**Green stormwater infrastructure is, perhaps, best appreciated within the context of how stormwater management has evolved over the past few decades.**

Then

Now

**The Evolution of Stormwater Management**



**Pipe-and-Pond Approach**

In the past, stormwater management meant getting rainwater off the site as quickly as possible using pipes to convey runoff directly to receiving waters. This direct discharge approach increased the speed and volume of stormwater surface discharge, which caused flooding. In response, large storage basins/ponds were constructed to temporarily detain runoff and slow discharge. Unfortunately, these storage basins offered little in the way of water quality treatment and often created downstream erosion.



**Multi-purpose practices**

Water quality issues and problems with peak-flow-centric management led to a new set of objectives for managing small storms. Separate storage volumes were allocated in BMP designs to meet recharge, water quality, and channel protection criteria in addition to flood control. New filtering and infiltration BMPs were introduced, and storage basin designs were revamped with extended detention, sediment forebays, and vegetation to improve pollutant removal and recharge.



**Reducing Runoff**

Despite improvements in the quality and control of stormwater discharges, we learned that replication of the natural hydrology is needed to maintain watershed health, meet climate challenges, and invest in nature-starved communities. To this end, the reduction of runoff leaving the site has become the new focus. Under the modern green stormwater infrastructure paradigm, the goal is to manage a larger fraction of the stormwater generated on-site by reducing or disconnecting impervious cover, using vegetation to absorb runoff, and diverting remaining surface flows into smaller practices for filtering, recharge, and reuse.

## New Development, Redevelopment, & Retrofits

Different opportunities will arise for advancing stormwater management objectives depending on the development situation. New development is an earth change operation that takes place on an undeveloped, presumably vegetated, property. All new development adds to existing hydrologic impacts, such as downstream sedimentation, flooding, gut erosion, or water quality impairment *if* stormwater runoff is not completely managed on site.

Redevelopment activities that take place on a previously developed site can result in either a maintaining of the status quo or an improvement in site conditions by managing stormwater for new and existing impervious cover at the site. Some communities require that stormwater improvements be made during non-emergency repairs or during the regrading of roads and parking lots.

Retrofitting involves actively looking for sites (developed or undeveloped) to construct stormwater facilities for the sole purpose of restoration. Capitalizing on redevelopment and retrofit opportunities to fix existing sites with inadequate stormwater management is the only way to restore watershed conditions.

## Social Equity

Social equity is the impartial treatment and fairness towards all people regarding social policies. Promoting equity and continually investing in communities to build capacity and make them more livable is a benefit to all and will ensure future viability. Environmental decisions must be made as part of a comprehensive approach that includes social equity, to improve community sustainability. Social inequities have—and continue to be—intricately connected to environmental disparities. Most people can quickly point to increased wastewater, drinking water, and solid and hazardous waste issues in disinvested, vulnerable communities. However, stormwater issues are also prevalent in these places such as insufficient or failing stormwater infrastructure, lack of green space and irregular development patterns that lead to increased and more frequent flooding, as well as chronic water quality concerns (**Figure 1.10**). Intense rainfall, steep slopes, and tight soils exacerbate these



*Figure 1.10. The Smith Bay community on St. Thomas experiences frequent flooding and is targeted for FEMA Hazard Mitigation funds for green stormwater infrastructure to improve drainage conditions and investment in the community recreational facilities.*

stormwater problems in the VI. Change is needed to ensure a basic right to live in a clean, healthy environment is met for all, and that there is an equitable distribution of the benefits from regional stormwater efforts. The VI's complex history of colonization and slavery, together with its vulnerability relative to climate change, elevate this need for environmental justice and sustainable development.

As discussed above, using green stormwater infrastructure (GSI) to manage stormwater quantity and quality has the added benefits of also addressing many other public health issues, including improving air quality, reducing heat island effects, neighborhood beautification and green space, reduced crime, and added climate resiliency. However, in many places, GSI has mostly been implemented in higher income areas where funding was readily available to “demonstrate” these practices and/or there were vocal advocates requesting or demanding nature-based solutions.

The updated EPH attempts to address these social/stormwater inequities by requiring GSI as the primary management mechanism in the VI and setting consistent planning and design standards island-wide to ensure that all populations experience GSI's benefits as new and redevelopment continues. While creative, on-the-ground outreach needs to be targeted to those areas least likely to be reached by traditional community engagement efforts, the hope is that this handbook can lay the groundwork for those efforts, providing easily accessible on-line information for all.

## Environmental Justice

According to US EPA's definition (<https://www.epa.gov/environmentaljustice/learn-about-environmental-justice>), "Environmental justice (EJ) is the fair treatment and meaningful involvement of all people regardless of race, color, national origin, or income with respect to the development, implementation and enforcement of environmental laws, regulations and policies.

Fair treatment means no group of people should bear a disproportionate share of the negative environmental consequences resulting from industrial, governmental and commercial operations or policies.

Meaningful involvement means:

- People have an opportunity to participate in decisions about activities that may affect their environment and/or health;
- The public's contribution can influence the regulatory agency's decision;
- Community concerns will be considered in the decision making process; and
- Decision makers will seek out and facilitate the involvement of those potentially affected.
- All people have a right to be protected from environmental hazards and to live in and enjoy a clean and healthful environment.

## Climate Resiliency

In the coming decades the VI is likely to experience an increased vulnerability to severe storms, reduced availability of fresh water during the dry season, loss of coral reef ecosystems, and more uncomfortably hot days due to climate change. Stormwater management approaches will need to evaluate projections and plan accordingly (i.e., appropriately size practices and piped conveyances for high end precipitation amounts and increased intensities, consider the effect of rising sea levels at discharge locations; increase rainwater harvesting capacity, and plant more shade trees and drought tolerant vegetation).

### Precipitation

**Figure 1.11** shows the NOAA estimates of annual rainfall (range of 30-60 inches) across the USVI from 1981-2020. Higher elevations and the western or leeward side of the islands receive more rain. Most rainfall comes in frequent, brief showers; tropical

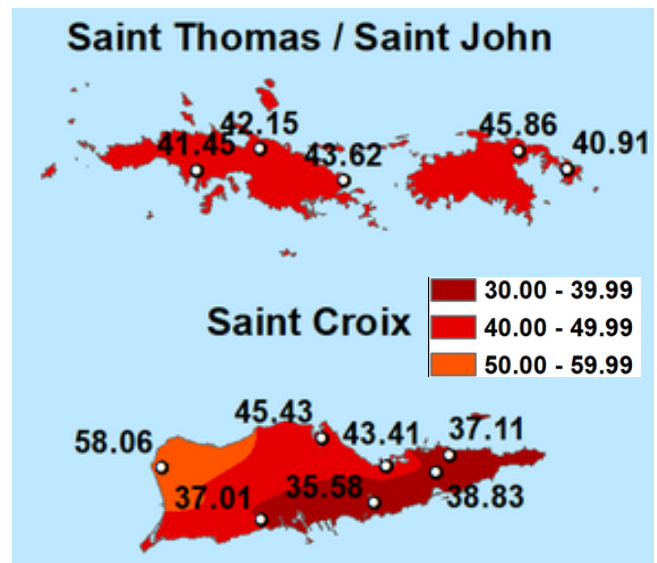

Figure 1.11. USVI mean annual rainfall totals (in inches) 1981-2020 (NOAA NWS)

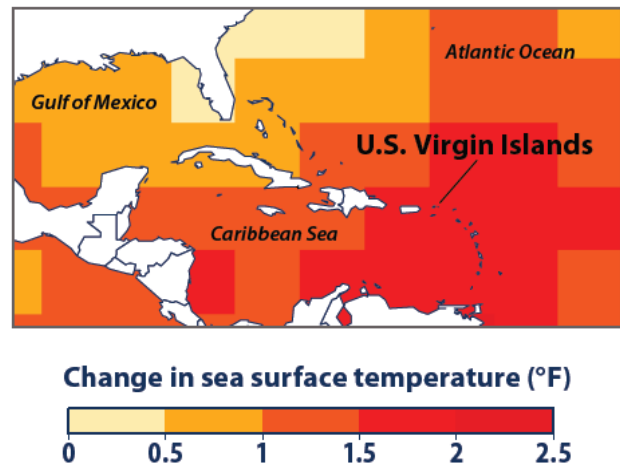

Figure 1.12 Sea surface temperatures have risen 2 degrees around the USVI since 1901 (EPA, 2016).

storms bring heavier, more intense rains that are more infrequent (Santiago-Rivera & Colon-Dieppa, 1986) with rains of more than 3 inches occurring about once a year" (NRCS, 2000). Climate predictions call for up to 25% drier region by the 2080s due to warming air and ocean temperatures (**Figure 1.12**). Individual rainfall intensities and hurricane frequency (and intensity) are projected to increase. Two category 5 hurricanes in 2017 and the intense flooding that followed are fresh examples of this altered storm pattern.

Drought occurrence and duration are also increasing with the more drought periods recorded in the last two decades (**Figure 1.13**). There is evidence that cisterns, ponds and aquifers are taking longer to fill, and rainwater harvesting is a growing priority for farmers and residents. Access to freshwater is already an issue in the virgin Islands and water security is increasingly challenging.

### Flooding

During an average year, the total annual runoff in the VI ranges from 2-8% of rainfall but can be as high as 30% for individual storms when rainfall is intense and soil saturation is high (Adams et al., 1996) or possibly up to 75% runoff conversion if severe storms occur back-to-back (Cosner, 1972). Floodwaters rise and recede quickly during heavy storms because of the steep slopes and impermeable underlying volcanic rocks. In addition to existing flooding issues caused by a lack of stormwater management and drainage maintenance for existing urban areas, inland flooding is likely to become more frequent as storm intensities increase. Rainfall during heavy storms has increased by 33% percent in Puerto Rico since 1958, and similar trends are observed around the region where impacts to streams and damage to road crossings are occurring more often. Vulnerable populations are experiencing more and more flooding and the economic impacts are high (Waddell, 2021).

### Evaporation Rates

Evaporation rates in the VI are high because of the steady flow of trade winds and the warm temperatures and can exceed average annual rainfall (NRCS, 2000). Vegetative evapotranspiration rates of 40 to 42 inches per year were reported by Cosner (1972) which accounts for 90-95% of the rainfall (Gomez-Gomez, et.al, 1985) leaving 2-4 inches of the annual rainfall for groundwater and streams.

### Coral Loss

Widespread coral loss is predicted due in part to ocean warming, increasing acidity, and more frequent bleaching events (EPA, 2016). Improved water quality conditions are critical to giving coral populations a fighting chance.

### Sea Level Rise

A 1-inch rise in sea level has been occurring every ten years and the prediction is for an increase of 1-3 ft

over the next century. Coastal homes, resorts, and beach bars are likely to flood more often as sea level rises, storm surges become higher, and watershed runoff volumes increase. Stormwater discharges near the shore or mouth of a gut will need to evaluate if

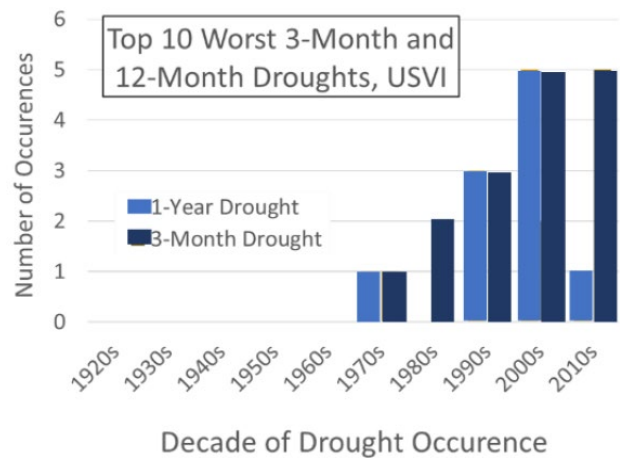

Figure 1.13 Drought occurrences since 1920's (Waddell 2021).

## Shared Vulnerabilities of U.S. Caribbean and Pacific Islands

(from the USGCRP, 2018)

The U.S. Caribbean islands face many of the same climate change related challenges as Hawai'i and the US-affiliated Pacific Islands, including:

- Isolation and dependence on imports, making islands more vulnerable to climate-related impacts;
- Critical dependence on local sources of freshwater;
- Temperature increases that will further reduce supply and increase demand on freshwater;
- Vulnerability to drought in ways that differ from mainland regions;
- A projected significant decrease in annual rainfall in all (Caribbean) or parts (Hawai'i and Pacific Islands) of these regions;
- Sea level rise, coastal erosion, and increasing storm impacts that threaten lives, critical infrastructure, and livelihoods on islands;
- Prominent concerns about the economic consequences of coastal threats;
- Coral bleaching and mortality due to warming ocean surface waters and ocean acidification; and
- Threats to critical economic marine resources, including fisheries.

flow backups are likely to occur at outfall locations. Groundwater elevations will rise as the freshwater lens floats above intruding saltwater which may alter infiltration rates and depth of practice inverts.

Engineers and designers are likely to be required to account for anticipated climate change impacts for proposed projects based on sea level projections. The black line in **Figure 1.14** was proposed in 2017 by DPNR as a sea level rise trajectory in between federal high and low SLR estimates through the year 2100. Applicants should proactively consider how their project reduces vulnerability and susceptibility to storm surges and abnormally large rainfall events.

### Regulations and Permitting

Concern for the environment, including plant, soil and water resources, was made a matter of public policy through passage of the Soil and Water Conservation District Law and the Environmental Protection Law of 1971, as amended. The Environmental Protection Program, overseen by the Virgin Islands Department of Planning and Natural Resources (DPNR), promulgates rules and regulations in accordance with the Environmental Protection Law to “...prevent improper development of land and harmful environmental changes” (VIDCCA, 1979). This Program includes both temporary erosion and sediment control and permanent, post-construction stormwater measures applicable to public and private developments, including the construction and maintenance of streets and roads. These rules and regulations are modified as necessary to meet the requirements of federal programs and territorial needs.

Depending on the project, site layout and stormwater management plans will likely need to comply with some of the following regulations, among others:

- Amended Virgin Islands Flood Damage and Prevention Regulations, Title 3 V.I.C., Chapter 22, Subchapter 401(b)(15): Includes regulations for building or alterations within the floodplain and adjacent to certain waterways. Allows DPNR to require more stringent buffer protections on watercourses.
- Protection of Indigenous, Endangered and Threatened Fish, Wildlife and Plants, Title 12 V.I.C., Chapter 2, §105: includes prohibition on pruning, cutting, or removal of mangroves in addition to

protection of nests and sensitive species. §106 outlines a policy of no net wetland loss.

- Community Heritage and Tree Law Title 12 V.I.C. Chapter 3A—encourages the conservation and preservation of trees; restricts public tree removal and pruning; and provides regulations for the care and maintenance of public trees, public nuisance trees and heritage trees.
- Water Pollution Control Title 12 V.I.C., Chapter 7—outlines monitoring, inspection, access, and enforcement provisions to comply with pollution control standards and states that which states that “...no person shall discharge or cause a discharge of any pollutant without a TPDES permit having been issued to such person...”
- Trees and Vegetation Adjacent to Watercourses Title 12 V.I.C., Chapter 13, §123—protects vegetation within 25 of gut bank or 30 ft of centerline, whichever is greater. For certain rainwater supply areas, Title 30 V.I.C. §67, trees and other vegetation are protected within 100 ft of watercourse, gut, ravine, or spring.
- Road and Highway Construction Title 20 V.I.C., Chapter 3—road standards, including Subchapter II, the “Complete Streets Act.”

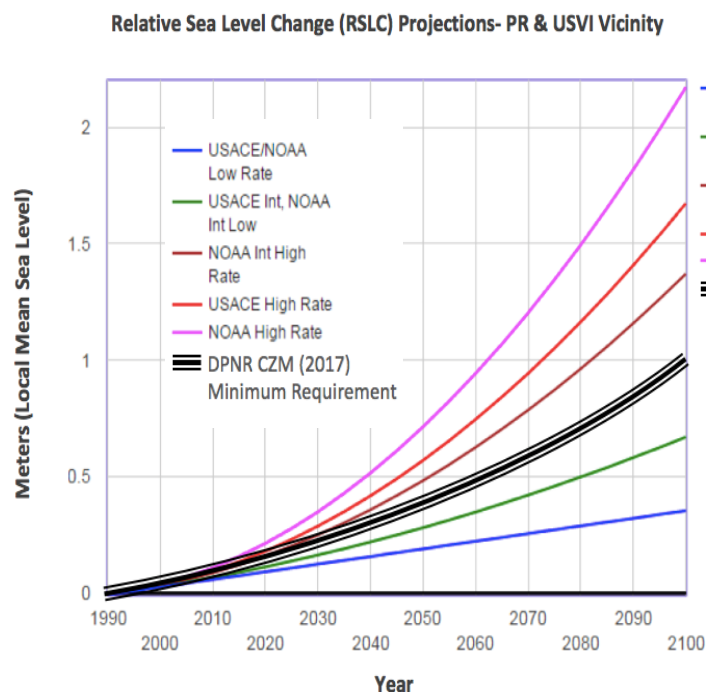

Figure 1.14. Relative Sea Level Change Predictions in the PR and USVI (DPNR, 2017)



- Zoning and Subdivisions Title 29 V.I.C. Chapter 3—includes requirements for various land use development, parking, open space, lot geometry, landscaping, etc. Also includes development of subdivisions, streets and surrounding areas and for water, drainage and sanitary facilities.
- Preservation of cultural or historical areas (archeological, scenic, or recreation) Title 29, Chapter 3 §280 and Chapter 17.
- Water supply, cisterns, gutters, downspouts, wells, Title 29 V.I.C., Chapter 5, Subchapter VIII, § 308—sizing and water reuse requirements.

The following agencies and permits are geared towards ensuring proper stormwater management for development activities:

- DPNR Department of Environmental Protections Earth Change Permit for gut and/or brush clearing, single lot and major development, as well as unpaved road maintenance.
- CZM major/minor development permit related to drainage criteria or required permit application information.
- Public Works road and driveway permit.
- The territorial pollutant discharge elimination system, known as TPDES, permitting and compliance program is a federally delegated program which permits and regulates discharges from several point and non-point sources including industrial facility storm water discharges, and storm water discharges from construction sites with over one acre of exposed soils.
- Floodplain and water quality certifications.

## 1.4 HOW TO USE THIS HANDBOOK

This Handbook is not intended to be read cover to cover, rather it is organized as a quick reference guide that can be referred to for instructions on how to manage stormwater at your site. For land clearing and development projects subject to stormwater regulations, you will need to show compliance with the construction and post-construction stormwater standards. The design and maintenance criteria described for specific structural practices should be followed to assume an acceptable level of performance for those practices.

**Chapter 2** outlines each stormwater standard and provides instructions on how to meet them. Standards are organized into three groups: construction standards for erosion and sediment control (ESC); post-construction stormwater standards (SW); and standards for unpaved roads (UR). The remaining chapters go into more detail on the various structural and non-structural practices that can be used to meet each standard.

**Chapter 3** discusses non-structural strategies that can be applied during initial site planning stages to help reduce stormwater impacts and save money on the construction and long-term maintenance of the stormwater system. The low impact development (LID) approach provides strategies for runoff reduction (e.g., multifunctional landscaping and impervious cover reductions). Good housekeeping, operation and maintenance (O&M) planning, and stormwater retrofitting are also discussed.

**Chapter 4** presents design and maintenance criteria for temporary practices used to prevent erosion of exposed soils and offsite sedimentation when it rains on construction sites. Practices are organized by function, including sediment barriers (silt fences), stabilization practices (hydroseeding), conveyance measures (check dams), trapping devices (sediment basins), and inlet/outlet protection (level spreader). When correctly implemented and maintained, these practices can significantly reduce erosion of valuable topsoil and downgradient damage to adjacent properties, roads, and receiving waters. This chapter also includes practices for managing drainage on unpaved roads. Keeping dirt/gravel on the road surface results in less road maintenance and better water quality for coral reefs.

**Chapter 5** presents design and maintenance criteria for structural stormwater control measures (SCMs) to handle runoff generated when it rains on roofs, parking lots, roads, and other impervious surfaces long after construction is completed. SCMs include vegetated filters, swales, permeable pavers, detention ponds, and constructed wetlands., with a preference for green stormwater infrastructure that mimics nature. Practices are organized by function, including runoff reduction for small storms, water quality treatment, pretreatment devices, and large storage practices.

**Appendix A** includes the Stormwater Standards checklists needed to document compliance with the standards, including the runoff reduction standard. Additional checklists may be available as part of Earth Change, CZM Major Permit, or other permit application packages.

**Appendix B** includes additional precipitation data for specific site locations in the USVI.

**Appendix C** offers example inspection and maintenance templates that can be adapted for project specific O&M plans.

## 1.5 THE STORMWATER MANAGEMENT PLANNING PROCESS

Landowners, developers, and engineers should follow these general steps when embarking on a development, redevelopment, or retrofit/restoration project.

**Step 1.** Review USVI land use restrictions, development regulations, and DPNR's permitting criteria to determine specific regulatory requirements for the development site and project type. Contact local CZM or DEP staff to clarify uncertainties. At a minimum, designers should review and adhere to the stormwater management standards and performance criteria in this handbook.

**Step 2.** Collect the site data needed to advance design concepts and develop the stormwater management approach, concepts, and designs. You will need to acquire the appropriate level of topographic and property line survey; understand rainfall, flow paths, and drainage areas; identify off-site land uses and watershed impairments; establish soil, groundwater and geologic conditions; identify natural resources (guts, trees, wetlands, threatened and endangered species, etc.); evaluate alternative roadway configurations; locate existing utilities (wells, wastewater, etc.); and assess contamination potential. You should be able to answer questions, such as: are there existing flooding and erosion problems? Is there a downstream wetland. Are there existing wellheads or sensitive species to avoid? Is spill containment a primary concern? Will soils affect SCM selection?

**Step 3.** Confirm required design criteria for the development site (Runoff Reduction,  $Re_v$ ; Water Quality,  $WQ_v$ ; etc.) to meet standards SW 2-6, as well as any applicable unpaved road standards. Determine if your project crosses multiple subwatersheds, discharges to different receiving waters, and if it creates new or replaces existing impervious cover. Draft a short report that quantifies the level of controls needed, the types of SCMs that can or cannot be used, and the basic quality and quantity control targets for the project.

**Step 4.** Prepare the initial site layout with an eye towards reducing the amount of stormwater runoff generated by your project (Standard SW-2) and avoiding disturbance of natural hydrology (Standard ESC-2). If unpaved roads are part of the design, Standards UR-1—3 and UR-5 should be reviewed. Minimizing the hydrologic alteration of a site is just as important (maybe more) as the stormwater control measures that will be implemented later. Once sensitive resource areas have been avoided, the next objective is to reduce the impact of land alteration by minimizing impervious areas to reduce the volume of stormwater runoff, increase groundwater recharge, and reduce pollutant loadings generated from a site. Runoff comes primarily from impervious surfaces, such as rooftops, roadways or any hard surface that prevents water from absorbing into the ground.

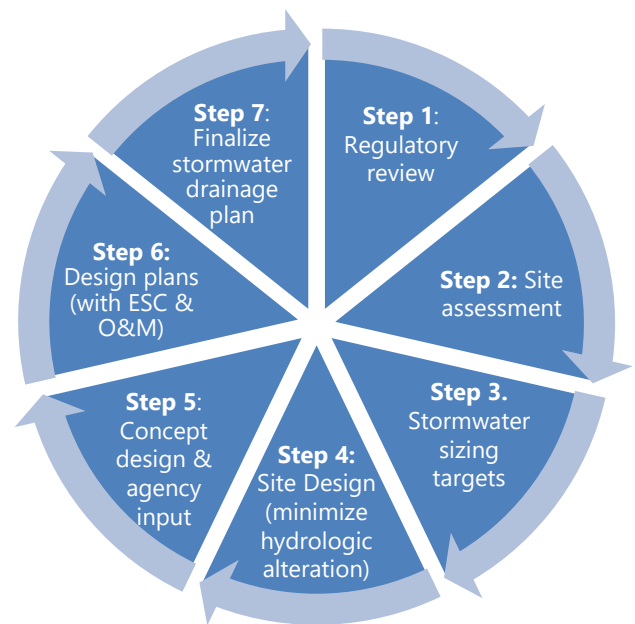

Figure 3.1 Steps to designing the stormwater management system.

After making every effort to avoid and reduce potential development impacts (use the Runoff Reduction Checklist in **Appendix A**), the next step is to determine the basic approach for effectively managing the remaining stormwater runoff at the source.

**Step 5.** Stormwater designers should use the approach determined in Step 4 to develop a conceptual design plan at approximately the 25% design stage that identifies:

- the location and types of SCMs to be utilized,
- the approximate footprint needed to meet sizing requirements,
- construction and maintenance access requirements; and
- general information needed to verify physical conditions, the overall feasibility of each SCM, adequate land area or required easements and/or right-of-way acquisition, etc.

At this stage, designers should coordinate with approving agencies to address potential constraints prior to final design. If additional data is determined to be necessary, designers can collect it and revise the concept before moving forward with full design. Field testing of soils or other physical characteristics for specific SCMs should also occur at this time.

**Step 6.** Move forward with site design, ensuring that the proposed construction and post-construction stormwater management systems meets Standards ESC 1-11 and SW-1 – 10 (see Stormwater Standards Checklist in **Appendix A** and design criteria in **Chapters 4** and **5**). Designers will need to work with the other project planners and engineers to develop the detailed plans, specifications, and construction quantity estimates for the stormwater management system. These plans will be of sufficient detail for construction of the proposed stormwater facilities and will include specifications, notes, tables, alignment, vertical controls, and all other features in sufficient detail for construction. Plans should also include construction staging, sequencing, and traffic control (if needed). If access roads will be unpaved for more than a year, it becomes more critical that drainage plans address Standards UR 1-10.

Both temporary and post-construction stormwater management plans must include an operation and maintenance (O&M) plan to ensure that it continues to

function as designed, as required by Standards ESC-10, SW-7, and UR-10. To meet this standard, designers should refer to the SCM-specific operation and maintenance guidance included in **Chapters 4** and **5**, as well as the example O&M plan included in **Appendix C**. The O&M plan should include frequency of inspection and maintenance, access locations, and sediment disposal options, among others. Designers should consider ease of access, maintenance equipment storage, sediments stockpiles, and traffic control needs as key factors in the design process.

**Step 7 – All final development proposals must include a stormwater management site plan for review by the approving agency.** The final plan should address all the applicable stormwater standards through compliance with the requirements of this manual. Designers should complete the Stormwater Standards Checklist in **Appendix A** to ensure sufficient information is provided with permit applications to document compliance.



# 2

# STORMWATER STANDARDS

## **2.1 STANDARDS FOR TEMPORARY EROSION AND SEDIMENT CONTROL ..... 2-4**

ESC-1. ESC Plan and Sequencing .....	2-4
ESC-2. Resource Protection .....	2-5
ESC-3. Clearing and Grading .....	2-6
ESC-4. Soil Stabilization .....	2-6
ESC-5. Slope Protection .....	2-7
ESC-6. Perimeter Controls .....	2-7
ESC-7. Settling Devices .....	2-7
ESC-8. Conveyance Structures .....	2-8
ESC-9. Education and Training .....	2-8
ESC-10. Practice Maintenance .....	2-9
ESC-11. Performance Accountability .....	2-9

## **2.2 POST-CONSTRUCTION STANDARDS FOR PERMANENT STORMWATER CONTROL ..... 2-9**

SW-1. No Unmanaged Runoff .....	2-10
SW-2. Runoff Reduction .....	2-11
SW-3. Water Quality .....	2-12
SW-4. Gut Protection .....	2-12
SW-5. Conveyance .....	2-13
SW-6. Overbank Flooding .....	2-14
SW-7. Operation & Maintenance .....	2-14
SW-8. Pollution Prevention .....	2-15
SW-9. Pollutant Hotspots .....	2-15
SW-10. Illicit Discharges .....	2-16

## **2.3 UNPAVED ROAD STANDARDS ..... 2-16**

UR-1. Controlled Runoff .....	2-17
UR-2. Upgradient Disconnection .....	2-17
UR-3. Road Width .....	2-18
UR-4. Surface Pitch .....	2-18
UR-5. Unpaved Surfacing Restrictions .....	2-19
UR-6. Reduced Surface Travel Times .....	2-19
UR-7. Conveyances and Outlets .....	2-20
UR-8. Surface Compaction .....	2-21
UR-9. Stabilized Cut & Fill Slopes .....	2-21
UR-10. Maintenance Agreements .....	2-21

To protect natural resources in the USVI, the negative impacts of stormwater must be avoided during site design, minimized during construction AND perpetually mitigated long after construction is completed. Stormwater standards for temporary construction activities, permanent post-construction, and for drainage control on unpaved roads are presented in this chapter (**Figure 2.1**). See **Appendix A** for a Stormwater Standards checklist for use by designers, applicants and permit reviewers to document that the stormwater standards have been adequately addressed. Each standard includes a concise description of purpose, specific requirements, and guidance on how to achieve compliance. These standards outline specific requirements for the volume of stormwater to manage on site and the level of required treatment. This information is intended to help designers and permit reviewers understand the requirements, identify the documentation needed to prove that the standard is being met, inform selection and design of stormwater control measures (SCMs), and avoid violations.

Stormwater standards come into play during all stages of the development process (**Figure 2.2**). Initial site planning and design will have a profound impact on the amount of runoff that is generated. Before site clearing, there are resource protection measures that must be taken. Once a site is cleared, there are erosion



Figure 2.1 The three stormwater standards categories.

control measures that must be installed and maintained throughout the construction process. After construction is done, the permanent stormwater facilities must be sized properly to accommodate anticipated rainfall, and these will require maintenance in perpetuity. Some of the standards are intended to improve accountability of site owners in complying with stormwater measures at all stages of the development process.

**Table 2.1** summarizes which standards are geared towards more effective documentation, practice sizing, or enforcement and the phase of development they are primarily applied.

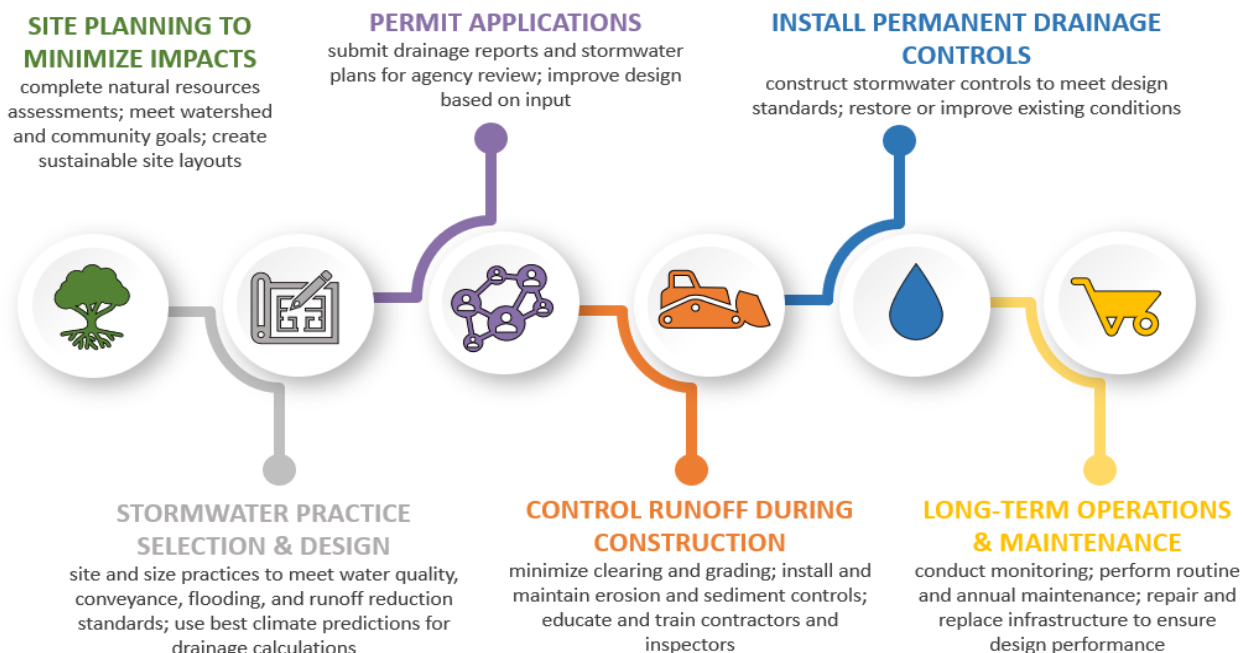







Figure 2.2 Stages of development process where stormwater management standards are applicable.

Table 2.1 Stormwater Standards Matrix

Stormwater Standards		Phase of Development				
		SITE PLANNING	SCM DESIGN	TEMPORARY SCMs	PERMANENT SCMs	O&M
						
Standards for Temporary Erosion & Sediment Control During Construction	ESC-1 ESC Plan and Sequencing <sup>1</sup>	●				
	ESC-2 Resource Protection <sup>1, 2</sup>	●		●		
	ESC-3 Clearing and Grading <sup>1, 2</sup>	●		●		
	ESC-4 Soil Stabilization <sup>2</sup>		●	●	●	
	ESC-5 Slope Protection <sup>2</sup>		●	●	●	
	ESC-6 Perimeter Controls <sup>2</sup>		●	●		
	ESC-7 Settling Devices <sup>2, 3</sup>		●	●	●	
	ESC-8 Conveyance Structures <sup>2, 3</sup>		●	●		
	ESC-9 Education and Training <sup>1</sup>			●		
	ESC-10 Practice Maintenance <sup>1, 4</sup>			●		
	ESC-11 Performance Accountability <sup>1, 4</sup>			●		
Standards for Permanent Post-Construction	SW-1 No Unmanaged Runoff <sup>1</sup>	●				
	SW-2 Runoff Reduction (1-yr, 24-hr) <sup>1, 2, 3</sup>	●	●		●	
	SW-3 Water Quality (1-inch) <sup>3</sup>		●		●	
	SW-4 Gut Protection (1-yr, 24-hr) <sup>3</sup>		●		●	
	SW-5 Conveyance (25 & 100-yr, 24-hr) <sup>3</sup>		●		●	
	SW-6 Overbank Flooding (10 & 100-yr, 24-hr) <sup>3</sup>		●		●	
	SW-7 Operation/Maintenance <sup>1</sup>		●			●
	SW-8 Pollution Prevention <sup>1, 2</sup>	●				●
	SW-9 Pollutant Hotspots <sup>1, 2</sup>				●	●
	SW-10 Illicit Discharges <sup>1, 4</sup>	●				●
Unpaved Road Drainage Standards	UR-1 Controlled Runoff <sup>1</sup>	●				
	UR-2 Upgradient Disconnection <sup>2, 3</sup>	●			●	
	UR-3 Road Width <sup>1, 3</sup>	●		●	●	
	UR-4 Surface Pitch <sup>2</sup>		●	●		●
	UR-5 Unpaved Road Restrictions <sup>2, 4</sup>	●				
	UR-6 Conveyances & Outlets <sup>2, 3</sup>		●	●	●	
	UR-7 Reduced Surface Travel Time <sup>2</sup>		●	●	●	
	UR-8 Surface Compaction <sup>4</sup>			●	●	●
	UR-9 Cut/Fill Slope Stabilization <sup>2, 4</sup>		●		●	
	UR-10 Maintenance Agreement <sup>1, 4</sup>					●

<sup>1</sup>Documentation standards identify written materials to be submitted with permit applications.

<sup>2</sup>SCM selection standards help designers determine the most appropriate measures to apply at a site.

<sup>3</sup>SCM sizing standards help designers determine the required dimensions for certain practices.

<sup>4</sup>Enforcement standards identify certain activities that must occur to avoid enforcement action.

## 2.1 STANDARDS FOR TEMPORARY EROSION AND SEDIMENT CONTROL

Erosion and sediment control (ESC) standards establish minimum guidelines for how stormwater should be managed during the site construction process. The clearing and grading phases of construction can be one of the most vulnerable times during the land development process and can result in significant water quality problems for downstream waters. The clearing of vegetation can expose soils to erosive rainfall and wind, which can result in off-site sedimentation, loss of topsoil, and clogging of downstream drainage infrastructure. Site planning, erosion prevention, and sedimentation control practices can have a significant and immediate effect on sediment retention when installed and maintained properly.

The following 11 ESC standards will help minimize the impact of site erosion on downstream properties, infrastructure, and ecological communities:

- ESC-1 ESC Plan and Sequencing
- ESC-2 Resource Protection
- ESC-3 Clearing and Grading
- ESC-4 Soil Stabilization
- ESC-5 Slope Protection
- ESC-6 Perimeter Controls
- ESC-7 Settling Devices
- ESC-8 Conveyance Structures
- ESC-9 Education and Training
- ESC-10 Practice Maintenance
- ESC-11 Performance Accountability

The objective, specific requirements and suggestions for achieving each standard are detailed below. Information on the design, installation, and maintenance of specific ESC practices can be found in **Chapter 4**.

### ESC-1. ESC Plan and Sequencing

#### Objective

Enable easier review and enforcement of ESC measures.

#### Requirement

ESC measures shall be shown on a separate, stand-alone, stamped plan sheet as part of the plan set submitted for Earth Change, TPDES, or other



*The extent of exposed soils at this steep-sloped construction site on St. Thomas illustrates why proper use of ESC measures is important for protecting downstream resources.*

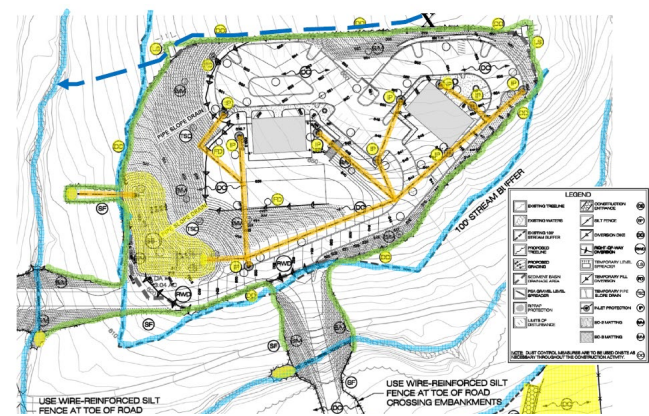

*This ESC plan includes perimeter controls, sediment traps, inlet and outlet protection devices, and slope stabilization practices (colored highlights).*

permitting applications. A narrative description shall accompany the ESC plan that documents compliance with each of the ESC standards, provides a site-specific construction sequence specifying the installation timing of ESC practices prior to and after site clearing. Not only should an Operations and Maintenance (O&M) plan be included, but also a signed O&M agreement with the responsible party.

#### How to Address this Standard

Stand-alone ESC plans and narrative shall be submitted with applicable permitting applications and be stamped by a licensed engineer. Stormwater Pollution Prevention Plan (SWPPP) submittals under the TPDES permit may be used for this purpose, as long as all the information described here is included. Planning for how to incorporate effective ESC throughout the development process is critical and detailed construction sequencing will vary by project.

**Figure 2.3** illustrates a general framework for construction sequencing.



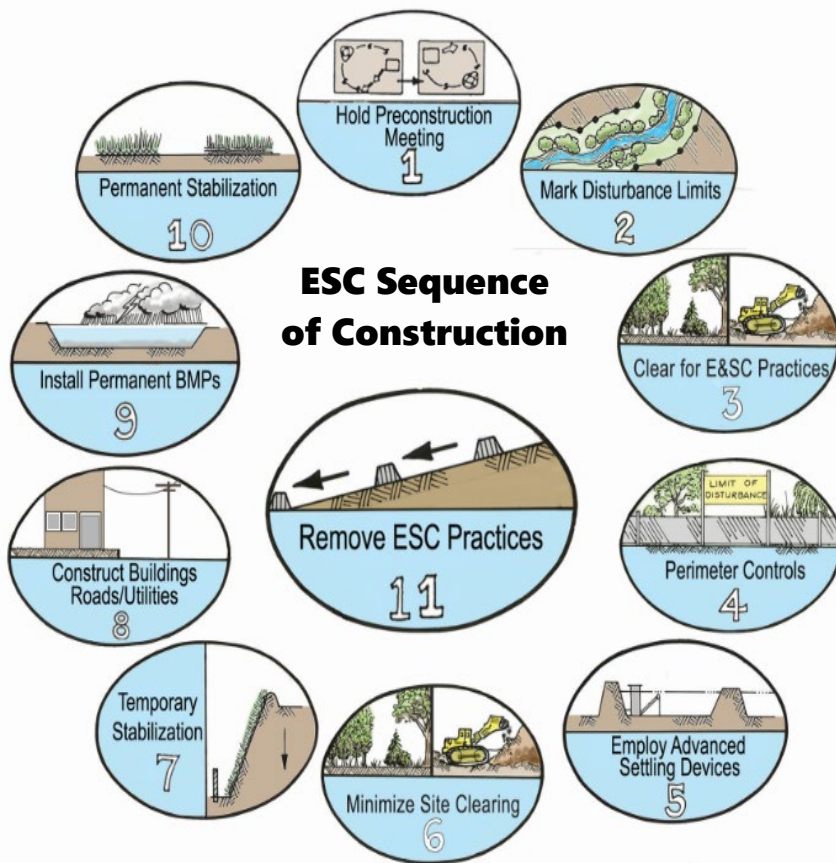

**Before Extensive Site Clearing:**

1. Hold a pre-construction meeting to make sure everyone is on the same page with the approved ESC Plan.
2. Mark limits of disturbance using flagging or fencing to protect waterway buffer, existing vegetation, and areas not to be disturbed.
3. Clear and grub only the areas necessary to install ESC control practices.
4. Install stabilized construction entrance and other necessary perimeter controls.
5. Install temporary sediment trapping devices and runoff conveyance systems.

**During Construction:**

6. Complete clearing and rough grading needed for buildings, roads, etc.
7. Provide temporary stabilization with vegetation or mulch for inactive, disturbed areas.
8. Construct utilities, roads, and buildings.
9. Convert temporary devices or install new, permanent stormwater practices.

**After Construction is Complete:**

10. Stabilize pervious areas with permanent vegetation.
11. Remove temporary erosion and sedimentation control practices.

Figure 2.3 Framework for proper sequencing of construction (adapted from Center for Watershed Protection)

**ESC-2. Resource Protection**

*Objective*

Protect important natural resources from construction impacts.

*Requirement*

The site surveys shown on the ESC Plan must depict all guts, ponds, wetlands, shorelines, and other protected natural resources (e.g., habitats for rare, threatened, and endangered species), as well as their jurisdictional buffers. The removal of vegetation within jurisdictional buffers is prohibited, with the exception of approved crossings. Vegetative buffers greater than the jurisdictional distances are encouraged to the maximum extent practicable.

*How to Address this Standard*

The most important first step to addressing this standard is to identify and delineate the natural resources at your site and clearly show the locations on your ESC Plan. Visible limits of disturbance and/or

perimeter controls shall be installed at the edge of the required disturbed areas, rather than automatically at the edge of the jurisdictional resource buffer. Protective fencing or other barriers shall be installed outside the drip lines of individual trees or around sensitive upland habitats to be protected from heavy equipment. Where valuable native plants will be impacted during clearing and grading, efforts shall be made to relocate and/or reuse on site.



No protection was provided for this stream during adjacent site construction.

### ESC-3. Clearing and Grading

#### Objective

Minimize soil exposure.

#### Requirement

Minimize “unnecessary” clearing and grading by limiting work to only those areas needed to build the project, including structures, utilities, roads, recreational amenities, post-construction stormwater management facilities, and related infrastructure. Provide a plan for separating, stockpiling, and reusing valuable topsoil that will be removed during grading. Provide cut/fill estimates and identify the number and species of trees >6-inch diameter that will be removed.

#### How to Address this Standard

This standard should be evaluated at the early stages of site design. Limits of disturbance shall be clearly identified on site plans and visibly demarcated in the field prior to clearing. Trees greater than >6-inch diameter that will be removed should be flagged and the species identified by a forest ecologist. Cut and fill estimates should be calculated based on the grading plan. Proposed ESC measures shall be installed prior to extensive site clearing. For this standard, “extensive site clearing” is defined as any clearing beyond what is necessary to access the site to install ESC measures. Construction activities should be scheduled to minimize soil exposure in the wettest months and during periods of coral spawning (August–November).

### ESC-4. Soil Stabilization

#### Objective

Stabilize any soil that must be exposed for duration of project to minimize export.

#### Requirement

Stabilization measures must be initiated as soon as practicable in portions of the site where construction activities have temporarily or permanently ceased, but no more than 14 days after the construction activity in that portion of the site has ceased. Whenever practicable and feasible, construction should be phased to limit disturbance to only one area of active construction at a time to reduce the total area requiring temporary stabilization. ESC practices shall not be removed until the area draining to them has been stabilized.



*Clear cutting of the entire site at one time eliminates any potential to protect trees or reduce the amount of exposed soil that now requires stabilization.*

#### How to Address this Standard

Temporary stabilization can be achieved through vegetation, mulching, erosion control blankets, or other combination of measures to prevent rain and runoff from eroding the soil. Temporary and permanent vegetative stabilization is considered achieved when ≥75% coverage has successfully been established and maintained at all disturbed areas. Percent coverage is evaluated by looking more closely at a small, representative area of coverage (e.g., 1 sq ft quadrant, rather than broadly across the entire site (see Vegetated Stabilization in **Chapter 4** for helpful graphic to estimate percent coverage). Therefore, if 75% of the site is stabilized except for a large bare area in northwest corner of the property, for example, then the site has not achieved this standard.



*Chipped wood generated during site clearing for a solar farm on St. Croix was spread at this site to cover exposed soils to prevent erosion.*

## ESC-5. Slope Protection

### Objective

Provide extra protection for disturbed steep slopes that are particularly vulnerable to erosion.

### Requirement

Steep slopes shall be protected from erosion by minimizing disturbance of the slope and, where grading is unavoidable, using a combination of erosion control measures. A steep slope is defined as any slope over 20% (5:1) in grade over a length of 50 feet.

### How to Address this Standard

Restrict clearing of existing slope vegetation to the required development footprint. Where grading is unavoidable, use diversion practices to prevent concentrated upland runoff from flowing uncontrolled down the slope and use stabilization practices for the slope itself. Temporary access roads should be stabilized immediately after construction with gravel, geoweb, or other measures to prevent erosion. Permanent roads or driveways should be stabilized, and drainage infrastructure installed immediately after construction.

## ESC-6. Perimeter Controls

### Objective

To prevent sediment-laden runoff from leaving the site.

### Requirement

Prior to extensive site clearing, appropriate perimeter controls shall be installed. Control measures shall not negatively impact adjacent properties.

### How to Address this Standard

Perimeter controls include sediment barriers (e.g., stabilized construction entrances and silt fences), diversion practices (e.g., swales and berms), dust control, inlet protection, and other devices used at strategic locations to prevent sediment from being carried off-site via rain, wind, or tire tracking. Diversion practices should be used to divert upland runoff around planned areas of disturbance. Wash pads and other containment devices used for equipment cleaning, concrete truck cleanouts, and dewatering shall be designed to prevent off-site discharge.



*Silt fence is a commonly used perimeter control device to keep sediment from leaving a site.*



*Erosion gullies on an exposed steep slope are being stabilized with vegetation through hydroseeding (photo credit: Protectores de Cuencas).*

## ESC-7. Settling Devices

### Objective

Provide adequately sized sediment containment.

### Requirement

When sediment traps, basins, or other devices are proposed to collect and retain sediment-laden runoff to allow time for suspended sediments to settle out, they shall be sized to hold at least 1 inch of runoff from the contributing drainage area. These practices must be installed prior to extensive site clearing in the area draining to them.

### How to Address this Standard

This standard only applies to sites where settling devices are being used. First, define the total area draining to the device. Then, size settling device to hold at least 3,600 cubic feet per acre of drainage area

(equivalent to 1 inch). These practices must conform to embankment design standards and maintenance procedures in order to meet performance, safety, and potential post-construction use requirements. Accumulated sediments shall be removed when device volume is reduced by half and disposed of properly away from water resources.

## ESC-8. Conveyance Structures

### Objective

Manage concentrated flows through and around construction sites.

### Requirement

Conveyance structures (e.g., constructed diversion berms and swales; NOT natural guts) used to direct concentrated flows shall be stabilized to prevent erosion. These temporary conveyances must be installed prior to extensive site clearing and sized to handle the peak flow from the 10-year, 24-hour Type II storm event for all contributing drainage area, at a minimum. All outfalls shall be stabilized, and velocities dissipated, to prevent erosion at discharge locations.

### How to Address this Standard

Use appropriately sized and stabilized diversion and outlet protection practices to prevent erosion from concentrated flows through and around the site. This may require the use of check dams or other energy dissipaters as necessary to slow erosive velocities.

## ESC-9. Education and Training

### Objective

Ensure that those performing construction activities are knowledgeable about ESC.

### Requirement

Construction site managers (or superintendents) shall provide documentation that they have: 1) received ESC training; 2) are familiar with ESC practices described in this Handbook and how they function; and 3) have educated equipment operators and other site personnel on the proper application and maintenance of ESC practices for that project site.

### How to Address this Standard

Actively look for erosion control training courses for foremen and site supervisors to attend. Provide



*A sediment trap collects runoff from a construction site on St. Thomas East End.*



*This ditch is carrying high velocity runoff through an exposed construction site. The channel should be stabilized and have check dams to slow runoff and prevent erosion.*



*Agency sponsored training on construction site erosion and sediment control on St. Croix*

continuing education to avoid expiration of certifications. Walk through the site with workers during practice installation to ensure they understand the purpose of the practice and proper installation methods. Train workers on methods of routine inspection, notification procedures for when there is an observed problem, and how to maintain individual practices.

## ESC-10. Practice Maintenance

### Objective

Ensure approved practices are working as intended during all phases of construction.

### Requirement

To ensure proper function, ESC practices shall be aggressively maintained throughout all phases of construction, including periods of inactivity. Accumulated sediments must be disposed of properly away from water resources.

### How to Address this Standard

All ESC plans shall include an enforceable operation and maintenance (O&M) agreement to ensure that practices are maintained during the construction process. Copies of the ESC plan and O&M agreement must always be available on site during the construction process.



*If sediment-laden runoff is leaving a construction site, the construction site manager needs to identify the cause of failure, repair or add practices, and potentially amend the ESC plan.*

## ESC-11. Performance Accountability

### Objective

Ensure approved plan is working as intended during all phases of construction.

### Requirement

The goal of ESC standards is to reduce erosion and minimize off-site sedimentation. The construction site manager is responsible for ensuring that downstream natural areas, roads, and public infrastructure are protected from sedimentation to the maximum extent

practicable. Site managers and owners may be subject to DPNR enforcement action if they fail to protect these resources, regardless of how well the originally approved ESC plan was implemented.

### How to Address this Standard

If, once the plan is put into practice and it is found that additional measures are required or that some of the implemented measures are not working, the construction site manager shall submit amendments to the plan and make the necessary changes on site.

## 2.2 POST-CONSTRUCTION STANDARDS FOR PERMANENT STORMWATER CONTROL

Post-construction stormwater management standards are intended to establish USVI-specific requirements for site design and permanent stormwater control measures (SCMs) as they relate to the generation and management of stormwater, respectively. The goals of post-construction stormwater management are to:

- 1) Reduce the amount of runoff generated by minimizing impervious cover (e.g., parking lots, roads, roof, and compacted turf);
- 2) Reduce the volume of runoff discharged from a site;
- 3) Remove/prevent pollutants picked up and transported by stormwater; and
- 4) Reduce downstream gut erosion and flooding.

The 10 post-construction stormwater standards include:

- SW 1 No Unmanaged Runoff
- SW 2 Runoff Reduction
- SW 3 Water Quality
- SW 4 Gut Protection
- SW 5 Conveyance
- SW 6 Overbank Flooding
- SW 7 Operation/Maintenance
- SW 8 Pollution Prevention
- SW 9 Pollutant Hotspots
- SW 10 Illicit Discharges

Each standard is described in more detail below, including the objective, specific requirements, and guidance on how to address.



*Post-construction stormwater management includes permanent practices designed to reduce the volume, filter out pollutants, and prevent downstream flooding impacts caused by impervious cover and other watershed alterations.*

SCM sizing criteria for managing small and large rainfall events are based on updated rainfall analyses, but these precipitation estimates use historic data that may not adequately forecast future climate conditions. It is anticipated that better rainfall estimates will become available for the Caribbean and should be used by regulators and engineers for stormwater design. Precipitation information is presented in **Appendix B**. Design criteria for accepted SCMs are described in **Chapter 5**.

It is important to note that applicants meeting Standard 2 automatically meet Standards 3 and 4. Sites with direct discharges to the ocean are exempt from Standards 4 and 6, since there are no downstream guts or flood potential.

**Applicants meeting Standard 2 are automatically presumed to meet Standards 3 and 4. Sites with direct discharges to the ocean are exempt from Standards 4 and 6.**

### SW-1. No Unmanaged Runoff

#### *Objective*

Establish appropriate stormwater management approach for all types of regulated development and affected water resources.

#### *Requirement*

No stormwater runoff shall leave a new development or redevelopment site without adequate management, as defined below:

**New Development:** All stormwater runoff generated from new disturbed areas (buildings, parking lots, roads, and other impervious surfaces) shall be managed on site by addressing all remaining post-construction standards (SW Standards 2 – 10). New development on vegetated land is subject to the standards even if other portions of the site are currently developed.

**Redevelopment:** Redevelopment of existing disturbed areas shall be managed by addressing SW Standards 2, 3, and 7 through 10. Specifically, Standards 2 and 3 (runoff reduction and water quality) shall be addressed with one of, or a combination of, the following techniques:

- Reduce existing impervious area by at least 50% of the redevelopment area; or
- Use on-site, non-structural or structural SCMs to provide reuse, recharge, and water quality management for at least 50% of redevelopment area. If none of the above options are practical, alternatives may be proposed that would achieve an equivalent pollutant reduction by using a combination of other types of SCMs and strategies, including treating 100% of the redevelopment area by SCMs with a lesser pollutant removal efficiency than stipulated in Standard 3.
- For extremely space-limited or otherwise constrained sites, implement off-site SCMs in the same watershed that provide reuse, recharge, and water quality management for an area equal to or greater than 50% of redevelopment areas. This option requires the applicant to satisfactorily demonstrate that impervious area reduction, non-structural, and/or structural SCMs have been implemented to the maximum extent practicable on-site.

An approved off-site location must be identified, the specific management measures described, and an implementation schedule developed in accordance with agency review. The applicant must also demonstrate that there will be no downstream drainage or flooding impacts as a result of not providing on-site management for large storm events.

**Critical Areas:** Stormwater discharges to critical areas (e.g., coral reefs, swimming beaches, wellhead protection areas, designated sensitive ecosystems, etc.)

or to impaired receiving waters may be subject to additional performance criteria, as determined by DPNR (e.g., type of stormwater practice allowed, enhanced pollutant removal, additional pollution prevention controls, or reduced impervious cover, etc.).

### *How to Address this Standard*

Applicants must document whether the site qualifies as new development, redevelopment, or a combination of the two. A summary table must be provided with the permit submission that clearly identifies the breakdown of new vs. redevelopment areas within the site and the associated requirements. In addition, applicants must identify the water resources impacted by stormwater discharges from the site and any known designations for those water resources (e.g., sensitive ecosystems or impaired waters).

## SW-2. Runoff Reduction

### *Objective*

Reduce the total volume of runoff produced at a site using a combination of non-structural and structural practices.

### *Requirement*

Designers shall use LID strategies and site design techniques to reduce the generation of stormwater runoff to the maximum extent practicable such that there is no discharge from the 1-year, 24-hour Type II design storm (i.e., the entire runoff volume is reused, infiltrated, evaporated, or otherwise retained on site).

For sites located in aquifer recharge areas, efforts will be made to infiltrate the 1-inch of rain using structural and non-structural methods. Recharge must occur in a manner that protects groundwater quality (e.g., pretreatment to remove soluble pollutants). The recharge requirement may be specifically waived if an applicant can demonstrate a physical limitation that would make implementation impracticable or where unusual geological or soil features may exist.

All development proposals must include a completed Runoff Reduction checklist that shows compliance with this standard for review by the approving agency. If full compliance is not provided, an applicant must document why key steps in the process could not be met and what is proposed as mitigation.



*Cisterns and permeable pavers are techniques that can be used to reduce runoff volumes on site.*



*Vegetated filters like rain gardens can be integrated into the landscape and used to clean runoff before it is discharged off site.*



*Redevelopment projects and road improvements offer the best opportunity to fix existing water quality and stormwater problems.*

Applicants meeting this standard are presumed to automatically meet Standards 3 and 4.

The site design process must include measures and/or methods to:

- Protect as much undisturbed open space as possible to maintain pre-development hydrology and allow precipitation to naturally infiltrate into the ground;
- Minimize soil compaction and restore soils compacted due to construction activities or prior development;
- Provide low-maintenance, native vegetation that encourages retention and minimizes the use of lawns, fertilizers, and pesticides;
- Minimize impervious surfaces;
- Break up or disconnect the flow of runoff over impervious surfaces;
- Manage precipitation as close as possible to the point it reaches the ground; and
- Use practices that maximize rainwater harvesting (reuse), infiltration, and/or evapotranspiration.

#### *How to Address this Standard*

Start during site design to reduce the overall volume of runoff that will need to be managed. A runoff reduction checklist is included in **Appendix A**. Consider that climate predictions indicate drier annual conditions, which is already contributing to dwindling freshwater and incentives for rainwater harvesting. Designers shall use the most updated rainfall data available (see **Appendix B**) and the models TR-55 and TR-20 (or approved equivalent) for determining the runoff volume from the post-development 1-year, 24-hour Type II storm.

More guidance on potential runoff reduction techniques at the planning stage is included in **Chapter 3**. Applicable structural SCMs are further described in **Chapter 5**.

**No additional calculations or stormwater control measures (SCMs) are required for Standards 3 or 4, if an applicant has fully met Standard 2.**

## SW-3. Water Quality

### *Objective*

Design stormwater SCMs to remove pollutants and provide recharge, where applicable, to protect coastal, surface water, and groundwater resources.

### *Requirement*

Stormwater runoff from the 1-inch rain event must be adequately treated by acceptable SCMs designed to remove 85% removal of total suspended solids (TSS), 60% removal of pathogens, 30% removal of total phosphorus (TP), and 30% removal of total nitrogen (TN); and sized to capture the prescribed water quality volume (WQ<sub>v</sub>). If an applicant has fully met Standard 2, it is presumed that this standard is also met; thus, no additional calculations or SCMs are required.

### *How to Address this Standard*

Based upon documented removal rates, the structural SCMs listed in **Chapter 5** are presumed to meet these standards when properly designed, constructed, and maintained. Pretreatment is required for water quality treatment practices where specified in the design guidelines.

The water quality volume (WQ<sub>v</sub>) is the amount of stormwater runoff from any given storm that must be captured and treated to remove a significant fraction of stormwater pollutants on an average annual basis. The required WQ<sub>v</sub>, which results in the capture and treatment of the entire runoff volume for 90 percent of the average annual storm events, is equivalent to the runoff associated with 1 inch of rain. The WQ<sub>v</sub> is calculated using the following equation:

$$WQ_v = (1") (I) / 12$$

where WQ<sub>v</sub> = water quality volume (ac-ft); and  
I = impervious area (acres)

## SW-4. Gut Protection

### *Objective*

Design stormwater practices to prevent discharges from contributing to excessive gut erosion.

### *Requirement*

For sites with direct discharges to a gut, a gut protection volume (Gp<sub>v</sub>) shall be provided by means of



24 hours of extended detention storage for the 1-year, 24-hour Type II design storm event runoff volume from the site, and stabilized outfalls must be provided. Guts with and without perennial flows need protection. Sites with direct discharges to coastal waters are exempt from this standard. If an applicant can fully meet Standard 2, it is presumed that this standard is also met; thus, no additional calculations or SCMs are required.

*How to Address this Standard*

Designers shall use the most updated rainfall data available and the models TR-55 and TR-20 (or approved equivalent) for determining the  $Gp_v$ . The model shall include all off-site contributing areas, which should be modeled based on anticipated future buildout conditions. The required minimum  $Gp_v$  shall be computed by calculating 65% of the direct runoff volume from the post-development 1-year, 24-hour Type II storm (Short-cut sizing method; Harrington, 1987), using the following equation:

$$Gp_v = 0.65 * V_r$$

where  $Gp_v$  = required gut protection storage volume; and

$V_r$  = runoff volume from 1-year, 24-hour Type II storm.

The  $Gp_v$  shall be released at roughly a uniform rate over a 24-hour duration. To determine the average release rate, use the following equation:

$$\text{Average release rate} = V_r / T$$

where  $V_r$  = defined above; and

$T$  = extended detention time (24 hours).

**SW-5. Conveyance**

*Objective*

Ensure that conveyance infrastructure (e.g., pipes, channels, culverts, etc.) are adequately sized to pass peak flows from large rain events in a safe and non-erosive manner.

*Requirement*

Post-construction open and piped conveyance systems must be designed to provide adequate passage for flows leading to, from, and through stormwater management facilities for at least the peak flow from the 25-year, 24-hour Type II design storm event from



*Standard 4 is intended to protect guts from erosive forces that may be generated from direct stormwater discharges upstream.*



*Structural practices will need to be sized to attenuate peak discharge rates to minimize downstream flooding (photo credit: Frank Galdo).*

the entire contributing drainage area. A description of flow paths during the 100-year, 24-hour Type II design storm event shall also be included.

*How to Address this Standard*

Designers shall use the most updated rainfall data available and the Rational Method for sizing the conveyance system. Since climate change projections indicate higher intensity of big storm events, consideration should be given to upsizing conveyance pipes, culverts, and open channels. This could be done by adding a factor of safety (2x) to modeled flow estimates, using the high end of precipitation ranges, and/or sizing for a larger design storm. Models should include all off-site contributing areas, which should be based on anticipated future buildout conditions.

## SW-6. Overbank Flooding

### Objective

Prevent an increase in the frequency and magnitude of overbank flooding and protect downstream and abutting structures from flooding.

### Requirement

Downstream overbank flood protection must be provided at each site by attenuating the post-development peak discharge rate to the pre-development levels for the 10-year and 100-year, 24-hour Type II design storm events (i.e., matching peak flows not volumes). In addition, designers must demonstrate that runoff from the site for storms up to the 100-year, 24-hour Type II design storm events actually reach proposed structural practices designed to meet this standard.

### How to Address this Standard

Designers shall use the most updated rainfall data available and the models TR-55 and TR-20 (or approved equivalent) for determining the required storage volume and outlet control structure design for matching peak flows from the 10-year and 100-year storms (Note: this does not equate to full on-site storage of the total runoff volume for these storm events, only matching peak discharge rates). Model shall include all off-site contributing areas, which should be modeled based on anticipated future buildout conditions.

## SW-7. Operation & Maintenance

### Objective

Ensure approved practices function as intended throughout their design life.

### Requirement

The stormwater management system, including all non-structural and structural stormwater controls and conveyances, must have an enforceable operation and maintenance plan and agreement. **Appendix C** includes sample templates for an O&M plan.

**Sites discharging directly to coastal waters are exempt from Standards 4 and 6 since there is not a receiving gut or downstream flooding potential.**



*Excessive volume and high velocity runoff conveyed in open channels, pipes, and guts can cause flooding, undermine roads, and lead to other infrastructure damage (photo: Valerie Peters).*



*This sediment forebay to a detention pond in Coral Bay will require ongoing maintenance to remove accumulated sediment for the basin to properly function.*

### How to Address this Standard

The long-term Operation and Maintenance Plan shall at a minimum include:

- Stormwater management system(s) owners and party(ies) responsible for operation and maintenance, including how future property owners will be notified;
- Stormwater management system and the requirement for proper operation and maintenance;
- The routine and annual maintenance plan for each practice to be undertaken after construction is complete;
- A maintenance log for tracking inspections and repairs;

- A plan that is drawn to scale and shows the location of all stormwater SCMs along with the discharge point;
- A description and map of public safety features;
- An operation and maintenance budget; and
- Funding source for operation and maintenance activities and equipment.

## SW-8. Pollution Prevention

### *Objective*

Prevent, to the maximum extent practicable, pollutants from coming into contact with stormwater runoff.

### *Requirement*

All sites require the use of source control and pollution prevention measures to minimize the impact that land use may have on stormwater runoff quality.

### *How to Address this Standard*

The pollution prevention measures shall be outlined in the submitted Stormwater Management Plan, including how future property owners will be notified of these measures. SWPPP submittals under the TPDES permit may be used, as long as all the information described here is included.

## SW-9. Pollutant Hotspots

### *Objective*

Prevent, to the maximum extent practicable, pollution from entering water resources.

### *Requirement*

Stormwater discharges from land uses or activities with higher potential pollutant loadings, defined as hotspots, are required to use specific structural and source control/pollution prevention practices. In addition, stormwater from a hotspot land use may not be recharged to groundwater without adequate treatment for the pollutant of concern as determined by the approving agency. The recharge prohibition at hotspots applies only to stormwater discharges that come into contact with the area or activity on the site that may generate higher potential pollutant load.

In addition, infiltration practices shall not be used where subsurface contamination is present from prior land use due to the increased threat of pollutant



*Some land uses are considered pollution hotspots and will have additional requirements for managing stormwater runoff.*



*Pollution prevention measures, such as protecting the ground from hydraulic fluids at boatyards, covering dumpsters, or providing secondary containment are an ongoing operational requirement.*

migration associated with increased hydraulic loading from infiltration systems, unless the contamination is removed and the site has been remediated, or if approved by DPNR on a case-by-case basis.

The land uses and activities considered stormwater hotspots are listed in the adjacent box. There are emerging contaminants, such as PFAS, that may expand the list of qualifying land uses as more information becomes available in the future.

### *How to Address this Standard*

Applicants must document the pollutants of concern at a hotspot and shall select stormwater practices that specifically address those pollutants. For example, hotspots with higher potential hydrocarbon loading (e.g., gas stations), the design must include oil-grit

separator or similar practice and must incorporate a shut-off device to isolate contamination in the case of a spill. Use sector-specific practices listed in the TPDES Multi Sector General Permit (MSGP), as applicable. In the areas where infiltration is not appropriate, other stormwater practices from **Chapter 5** can be used if they are lined (e.g., lined bioretention areas). See **Chapter 3** for a discussion of some non-structural pollution prevention measures.

### Stormwater Hotspot Land Uses

1. Areas within an industrial site (identified by SIC Code) that are the location of activities subject to the TPDES Multi-Sector General Permit (MSGP), which include the following general categories, further divided into 29 sectors (see permit for more information);
  - Heavy manufacturing
  - Mining, oil & gas
  - Hazardous waste facilities
  - Landfills
  - Recycling facilities
  - Steam electric power plants
  - Transportation industries (includes marinas and boatyards)
  - Sewage treatment facilities
  - Light industry
2. Auto fueling facilities (i.e., gas stations);
3. Exterior vehicle service, maintenance, and equipment cleaning areas;
4. Outdoor storage and loading/unloading of hazardous substances; and
5. Others that may be identified by the approving agency as necessary.

## SW-10. Illicit Discharges

### Objective

Prevent pollutants associated with illicit discharges from being discharged into Waters of the Territory, and to safeguard natural resources and the environment, public health, safety, and welfare.

### Requirement

All illicit discharges to stormwater management systems are prohibited, including untreated gray water and discharges from septic systems. The stormwater management system is the system for conveying, treating, and infiltrating stormwater on site, including stormwater best management practices and any pipes



*Illicit discharges include non-stormwater discharges (dry weather flow) such as those from leaking septic systems and dry cleaners.*

intended to transport stormwater to ground water or surface water. Illicit discharges to the stormwater management system (i.e., illicit connections), are discharges not entirely comprised of stormwater.

### How to Address this Standard

As a part of the permit submittal, applicants shall provide a signed statement documenting that there are no illicit discharges at the site.

## 2.3 UNPAVED ROAD STANDARDS

Many unpaved roads and driveways are constructed without permits and with little thought towards drainage design, maintenance, or offsite sedimentation impacts. For the purposes of this Handbook, unpaved roads include dirt, gravel, native rock, or other non-durable surfacing (i.e., not bituminous concrete or asphalt paving). Often, unpaved roads are cut as temporary accesses, yet they can remain unpaved for years and become a significant sediment source when designed or maintained improperly. Life-span confusion can lead to uncertainty as to what level of stormwater management should be provided. What is certain, however, is that more frequent and intense big storms will take a toll on unpaved roads that are not designed to handle even the smaller, more frequent storms.

While drainage management for unpaved roads and driveways should meet basic ESC and SW standards, there are 10 additional standards provided here that are adapted from the 2021 Unpaved Road Standards

for Caribbean and Pacific Islands (Kitchell et al., 2021). They are intended to supplement ESC and SW standards and focus on road designs to minimize surface erosion and reduce maintenance frequency. Design standards should be applied to new/proposed unpaved roads, as well as to existing road segments known for chronic surface erosion and sedimentation issues. The standards include:

- UR-1. Controlled Runoff
- UR-2. Upgradient Disconnection
- UR-3. Road Width
- UR-4. Surface Pitch
- UR-5. Unpaved Surface Restrictions
- UR-6. Reduced Surface Travel Time
- UR-7. Conveyances & Outlets
- UR-8. Surface Compaction
- UR-9. Stabilized Cut/Fill Slopes
- UR-10. Maintenance Agreement

**Chapter 4** provides design and construction details for drainage management practices specific to unpaved roads.

### UR-1. Controlled Runoff

#### *Objective*

Prevent sediment-laden discharges from new and existing unpaved roads.

#### *Requirement*

No unmanaged discharges to waterbodies, adjacent properties, or public roads are allowed from new unpaved road construction. Existing unpaved roads that discharge muddy runoff to waterbodies or public roads must be upgraded to meet these standards when undergoing significant maintenance or repair., such as widening, culvert replacement, or significant regrading that involves cutting into the surface course or bringing in offsite material).

#### *How to Address this Standard*

To effectively meet this standard, applicants will need to document that all of the road standards have been addressed in a drainage report or stormwater checklist. Road designers should be aware of the watershed they are in and if there are any designated use impairments due to turbidity. The contributing drainage area should be delineated to each discharge point from the road



*Unpaved roads should not be the source of sediment plumes in the bay. They should be designed for drainage to minimize surface erosion and overall maintenance burden, regardless of temporary or permanent status.*



*This rain garden in the Hope and Carton neighborhood on the east end of St. Croix intercepts driveway runoff before discharging onto the community's unpaved road.*

(including off site drainage) and practices to control erosion and sedimentation for each discharge point should be shown on the plan. Subdivision roads should be managed as part of the site's overall stormwater management plan. Individual driveways or access roads may need to be managed at the lot scale.

### UR-2. Upgradient Disconnection

#### *Objective*

Minimize the amount of runoff coming onto the unpaved road from connecting tie-ins (e.g., driveways and other roads), impervious cover, and surrounding hillsides. You only want to manage the runoff volume created on the road itself, not what is generated elsewhere. Reducing "run-on" volumes means less strain on road surface and less road maintenance.

### Requirement

Disconnect up-gradient impervious cover from the road surface.

### How to Address this Standard

Designers will need to understand the amount of runoff being contributed from surrounding drainage areas to each road segment as part of design and permitting. Where practical, interceptor ditches, berms, or slope contouring can be used to direct flows to pervious areas or stormwater practices. Tie-ins connecting to an existing unpaved road should disconnect their drainage to reduce additional flows.

## UR-3. Road Width

### Objective

Minimize the width of driving lanes to reduce the overall footprint of unpaved surfaces and the amount of runoff that must be managed.

### Requirement

Driving lane widths should be 10 ft (20 ft two lane travel way) or less for unpaved roads. An 18-22 ft travel way is standard and should be suitable for most minor roads. Lower speed, less used roads can be on the narrower end of range.

### How to Address this Standard

Road design sections should include dimensions of designated driving lanes, shoulders, ditches, and slopes within the right-of-way. The driving lanes should be as narrow as feasible. Pull outs can be added for narrower lanes to accommodate passing and turnarounds. Road widths must be approved during permitting for new construction and confirmed at project closeout. Widths must be maintained over time, or the road design updated to reflect increases in surface area and the potential loss of shoulders and original drainage controls. An evaluation of traffic patterns and vehicular needs must be provided to justify any waiver to this standard.

## UR-4. Surface Pitch

### Objective

Maintain the proper cross-slope or pitch needed for the drainage system to function properly. Out-sloped, insloped, and crowned road profiles dictate which



*Excessive road widths can create a much larger disturbance footprint than needed, lead to increased erosion and sediment loading, and require more extensive maintenance than originally planned.*

drainage practices will be used (see Road Planning section in **Chapter 3**). Unpaved roads typically require more pitch than paved roads due to surface porosity and roughness. Steeper roads may require a more pronounced pitch to ensure that water flows off to the side instead of down travel lane. Many roads will have segments of varying pitch, but out-sloped roads are preferred to minimize the use of ditches.

### Requirement

Maintain a 3-6% pitch on in/out-sloped roads, and a 4-6% pitch on crowned roads. Road surface must be elevated above drainage features to maintain positive drainage. Original road shape will be lost overtime due to traffic, erosion, and maintenance activities. Changes in road shape without adjustments to drainage controls can result in road failure.

### How to Address this Standard

Design plans must include road sections showing road shape and grade.

Proper pitch must be confirmed during construction inspections. As a general rule, there should be at least 1/2 inch to 3/4 inch of fall per foot across the road (4 to 6 %); this can be measured in the field with a hand level or survey equipment. Maintain road grade over time so runoff continues to flow as designed. Maintenance plans and agreements should include information to communicate proper road pitch to equipment operators.

## UR-5. Unpaved Surfacing Restrictions

### Objective

Avoid unpaved roads on steep slopes where erosion is likely and within wetland buffers or shoreline setbacks where sedimentation impacts are inevitable.

### Requirement

The maximum slope for unpaved roads is 20%. If steeper unpaved sections are necessary, then aggregate surfacing, more drainage controls, and more aggressive maintenance will be required. Segments with high erosion potential that are within 200 ft of the shoreline should have stabilized surfaces (aggregate, permeable pavers, paved) and drainage must be diverted into a stormwater practice.

### How to Address this Standard

For steep slopes ( $\geq 20\%$ ):

- Consider alternative road layouts to avoid or minimize the length or grade of steep segments.
- Pave roads (or segments) that exceed 20% slope. Paving is expensive but may be cost-effective in the long run. If paving is not feasible, an aggregate surface is required at a minimum (no loose dirt).
- Cross-drains and other drainage controls should be installed at more frequent intervals than those shown in **Chapter 4** to allow for a margin of safety. For example, if a turnout is required every 45 ft at 20% slope, install them every 25 ft if slopes are  $>20\%$  (actual site conditions will dictate the frequency of practice placement).
- Ensure that check dams are used in all ditches to slow erosive velocities and that flows are intercepted at all grade breaks.

For segments within 200 ft of shorelines, wetlands, or guts:

- Denote shoreline and buffer/setbacks on design plans during permitting. Evaluate the potential for the contributing road segment to convey eroded sediment water. If the road is a likely sediment source, install practices or stabilize the surface to reduce the chances that muddy runoff will reach the waterway.
- Road surfaces that have (or are likely to have) erosion issues should be made of aggregate or permeable or impervious pavements, and the



*Roads on steep slopes should be paved or stabilized with an aggregate surface (no loose sediment). Note that this road demonstrates paving at the steep section, gravel at mid-slope, and native material where flat.*

drainage should be diverted into a rain garden, filter strip, or other practice.

- Prioritize these areas on existing roads for maintenance and retrofitting.

## UR-6. Reduced Surface Travel Times

### Objective

Getting water off the road surface and out of ditches is the best way to manage drainage. Often, we don't provide enough turnouts to keep the total volume of water at a manageable amount. The steeper the slope, the more turnouts needed.

### Requirement

Provide an adequate number of turnouts for road slope or use check dams and demonstrate that the design can safely handle the 10-yr design storm.

### How to Address this Standard

If the design is insloped, make sure you can accommodate turnouts. See **Chapter 4** for recommended spacing. For 20% slope, one turnout should be provided every 45 linear feet. If you can't meet recommended spacing, consider using an alternative road shape or size conveyances with an additional factor of safety.

## UR-7. Conveyances and Outlets

### Objective

Design ditches, culverts, and outlets based on future drainage assumptions to reduce backups and slow down erosive velocities. Discharge of concentrated flows from ditches, cross drains, or turnouts can lead to erosion, particularly if discharging down a steep, fill slope. Outlets need to be reinforced and flows slowed and spread using dense vegetation, stone, plunge pools, or other dissipation techniques.

### Requirement

Designs must meet ESC-8 and SW-5 standards. Ditches and culvert pipes (e.g., under driveways or at gut crossings) should be sized to safely handle projected flows. Any pipes should have a minimum 18-inch diameter. If anything, culverts should be oversized to allow for increases in flow due to future development, ease of maintenance, and changes in rainfall patterns. Gut culverts should be at least as wide as the existing channel. If you can't meet the standard, you must use check dams in ditches and must design for the 10-yr, 24-hr storm (using most updated precipitation frequencies). All outlets should be stabilized, and concentrated flows dissipated to prevent erosion.

### How to Address this Standard

For ditches and culverts:

- Evaluate the size and condition of uphill and downhill conveyance structures.
- Delineate drainage area to each culvert (e.g., cross-drain, driveway, or stream culvert). Consider increased drainage volume and flow rates in the future and be conservative in your sizing to accommodate future development and larger, more intense storms.
- Consider using an alternative road shape such as out-sloped or crowned to eliminate ditches.
- Ditches that are un-lined, un-vegetated, or that lack check dams can begin unraveling during the first rain event. These features should be stabilized prior to construction closeout.
- Driveway culverts should have proper headwall protection to prevent ditch erosion.

For outlets:

- Identify proposed turnouts and discharge points during permit review and make sure they have proper protection (e.g., stone apron, plunge



*Runoff conveyed down the travel lane will quickly concentrate and erode surface materials. Better drainage designs aim to get water off the road surface at multiple intervals. The length of flow on this road shows an extended and undesirable surface travel time (photo: Coral Bay Community Council).*



*High volumes and velocities can lead to ditch erosion and backup at undersized driveway culverts.*

pool, vetiver, level spreader, or other energy dissipater).

- Locate and inspect discharge points in the field to ensure that they are stabilized. For discharges near streams and other waterbodies, follow the discharge to make sure the entire flow path is stabilized.
- Adjust stone or other practice if determined that it is not working properly.



## UR-8. Surface Compaction

### Objective

Ensure unpaved surfaces are adequately compacted to prevent the loss of surface material. This is particularly important for dirt roads where native soils are the only material being used for surfacing.

### Requirement

The road surface course must be compacted using a roller of 15 tons or higher (or equivalent).

### How to Address this Standard

Confirm by checking equipment rating or perform a compaction test during construction inspections.



Roller for compacting unpaved road surface (photo credit: *Protectores de Cuencas*).

## UR-9. Stabilized Cut & Fill Slopes

### Objective

Reduce erosion from cut and fill slopes along the road.

### Requirement

Meet standard ESC-5. Provide adequate temporary and permanent stabilization for cut and fill slopes.

### How to Address this Standard

- Evaluate soil conditions (e.g., dig a test pit) on site to determine erodibility of any exposed banks, slopes, and ditches.
- Use gabions, stone walls, soil bioengineering, vegetation, terracing, or combination of techniques for cut slopes, if needed.
- Use combination of pipe slope drains, erosion control matting, hydroseeding, silt socks, terracing, and other practices to stabilize fill slopes.
- Do not approve closeout project without satisfactory stabilization.



Vertical cut slope along the inside of an unpaved road.

road owners should be planning for that long-term maintenance commitment.

### Requirement

New private roads require an approved long-term maintenance agreement.

### How to Address this Standard

- Require submittal of a maintenance plan and signed maintenance agreement as part of permit application that identifies responsible parties, annual budget, and proposed maintenance contractor. This can be combined with the maintenance plan provided under standards ESC-10 and SW-7.
- Ensure Homeowners Associations plan for adequate maintenance funding.
- Consider legal mechanisms, grant subsidies, or partnerships to share maintenance costs for existing problem roads between the public and private sector.

## UR-10. Maintenance Agreements

### Objectives

Improve maintenance effectiveness by assigning responsible parties and setting long-term expectations for maintenance costs and tasks. Even where local permits cover road construction, the oversight generally stops there. Unpaved roads (like all infrastructure) require a lifetime of servicing. Private



# 3

## SITE DESIGN & PLANNING STRATEGIES

<b>3.1 GETTING TO KNOW YOUR SITE.....</b>	<b>3-2</b>
Watershed Context.....	3-2
Environmental Justice.....	3-4
Climate.....	3-4
Soils.....	3-7
Other Environmental Factors.....	3-12
Contributing Drainage Areas.....	3-13
Applicable Permits.....	3-14
<b>3.2 RUNOFF REDUCTION USING LID .....</b>	<b>3-14</b>
Vegetated Open Space Preservation.....	3-16
Soil Protection.....	3-17
Multi-functional Landscaping.....	3-17
Impervious Surface Diet.....	3-18
Runoff Disconnection and Distribution.....	3-19
<b>3.3 PLANNING FOR ROADS AND DRIVEWAYS .....</b>	<b>3-20</b>
Road Planning Principles.....	3-20
Designing for Drainage.....	3-23
Construction Planning.....	3-25
A Commitment to Maintenance.....	3-26
<b>3.4 GOOD HOUSEKEEPING PRACTICES.....</b>	<b>3-28</b>
Waste Disposal.....	3-28
Material Management.....	3-29
Spill Prevention and Response.....	3-30
<b>3.5. OPERATIONS AND MAINTENANCE .....</b>	<b>3-30</b>
Operations and Maintenance Plans.....	3-31
Functional System Components.....	3-31
Inspections.....	3-33
Scheduled and Corrective Maintenance.....	3-33
<b>3.6. RETROFITS AND REDEVELOPMENT .....</b>	<b>3-34</b>

Proper site planning not only helps conserve natural resources but also saves money during (and long after) construction. This chapter outlines a process for understanding the environmental resources on your site and offers several strategies to achieve the stormwater runoff reduction standard described in **Chapter 2**. This chapter also includes guidance on layout and drainage design for access roads and driveways, as well as general operations and maintenance steps. It is important to understand that these strategies must be embraced early in the planning process as they have direct implications on the extent of erosion and sediment control, post-construction stormwater management, and landscaping practices that will be necessary during the development process.

Site planning practices for sustainable stormwater management apply to the individual site, but the surrounding context and connections to adjacent properties can also play a role in how a site is developed. For this discussion, the site planning goal is to reduce the runoff volume and pollutant load generated by earth change and development activities. Sustainable site design strives to retain existing vegetation, reduce paving, and avoid the negative impacts development can have on downstream resources. Effective site layouts can reduce the need for structural, engineered stormwater control measures (SCMs)—thereby, reducing development costs and long-term maintenance burden borne by owners.

Fully embracing the stormwater management element of island site design will require capitalizing on aspects of local culture that already lend themselves to these strategies, overcoming the physical and regulatory challenges unique to island settings, and avoiding common mistakes. Fortunately, the following realities of the VI make this approach both attractive and practical:

- Freshwater is precious, especially as more frequent and longer duration droughts are anticipated in the USVI. Rainwater harvesting and non-potable reuse makes a lot of sense and is already common practice.
- Space is a premium, and large surface storage practices use lots of valuable real estate.
- Paving is expensive, so being smart with hardscapes comes naturally.

- Native soil is valuable, so minimizing site disturbance and maintaining existing vegetation has an economic (and aesthetic) benefit.
- Site clearing by hand is not uncommon. This approach provides much more control over selective clearing, tree protection, and soil protection practices.
- Like rainfall, proper SCM installation and maintenance can be unpredictable. It makes sense to break drainage areas up and distribute smaller control practices around the site to provide redundancy, rather than relying on a single big pond at the bottom of the hill.
- Evapotranspiration rates are high and vegetation growth rates are fast, making plants and evapotranspiration key elements of the stormwater management system.
- There are some terrestrial and wetland habitats in the USVI that are home to endangered plants and animals and that provide valuable environmental and social services. Regulatory oversight for wetland and forest habitat protection is currently limited in the VI; therefore, it is incumbent on individual landowners to maintain and restore these resources.

### 3.1 GETTING TO KNOW YOUR SITE

Before clearing a site, landowners, engineers, and architects need to understand the existing features of the land that is going to be developed. The first step in site planning (and permitting) is to assess the environmental and historic conditions of the site.

#### Watershed Context

A watershed is the land area that collectively drains to a particular waterbody when it rains. In the USVI, watersheds are delineated by surface drainage (not groundwater flows) generally to coastal embayments. There are approximately 50 watersheds in the USVI (**Figure 3.1**). Many of these watersheds are associated with water quality monitoring stations. Every few years, DPNR publishes an Integrated Waters Report that identifies which waterbodies are meeting designated use standards (e.g., swimming, and fishing) and which ones are impaired due to a pollutant (e.g., bacteria, turbidity, dissolved oxygen).

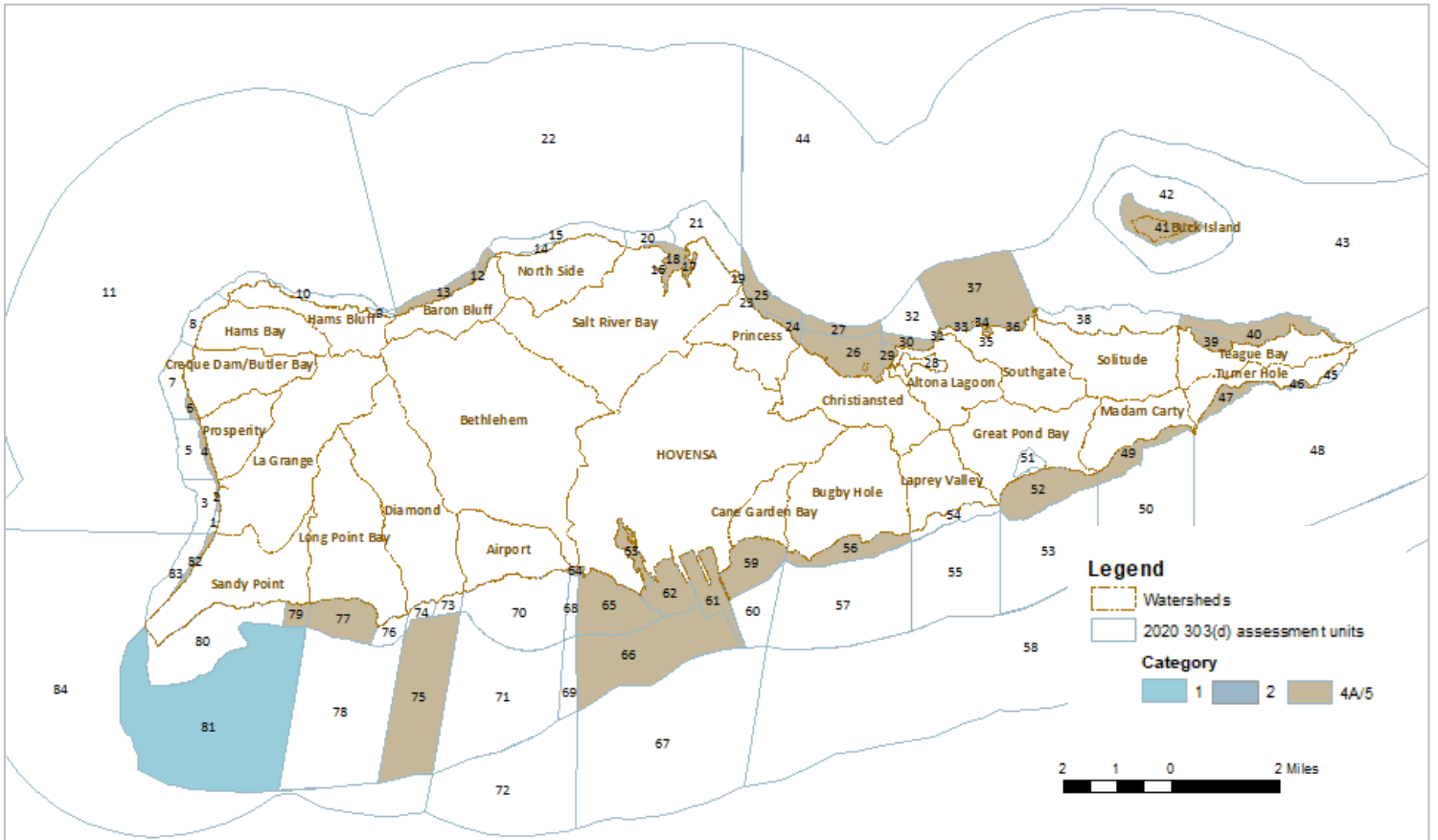
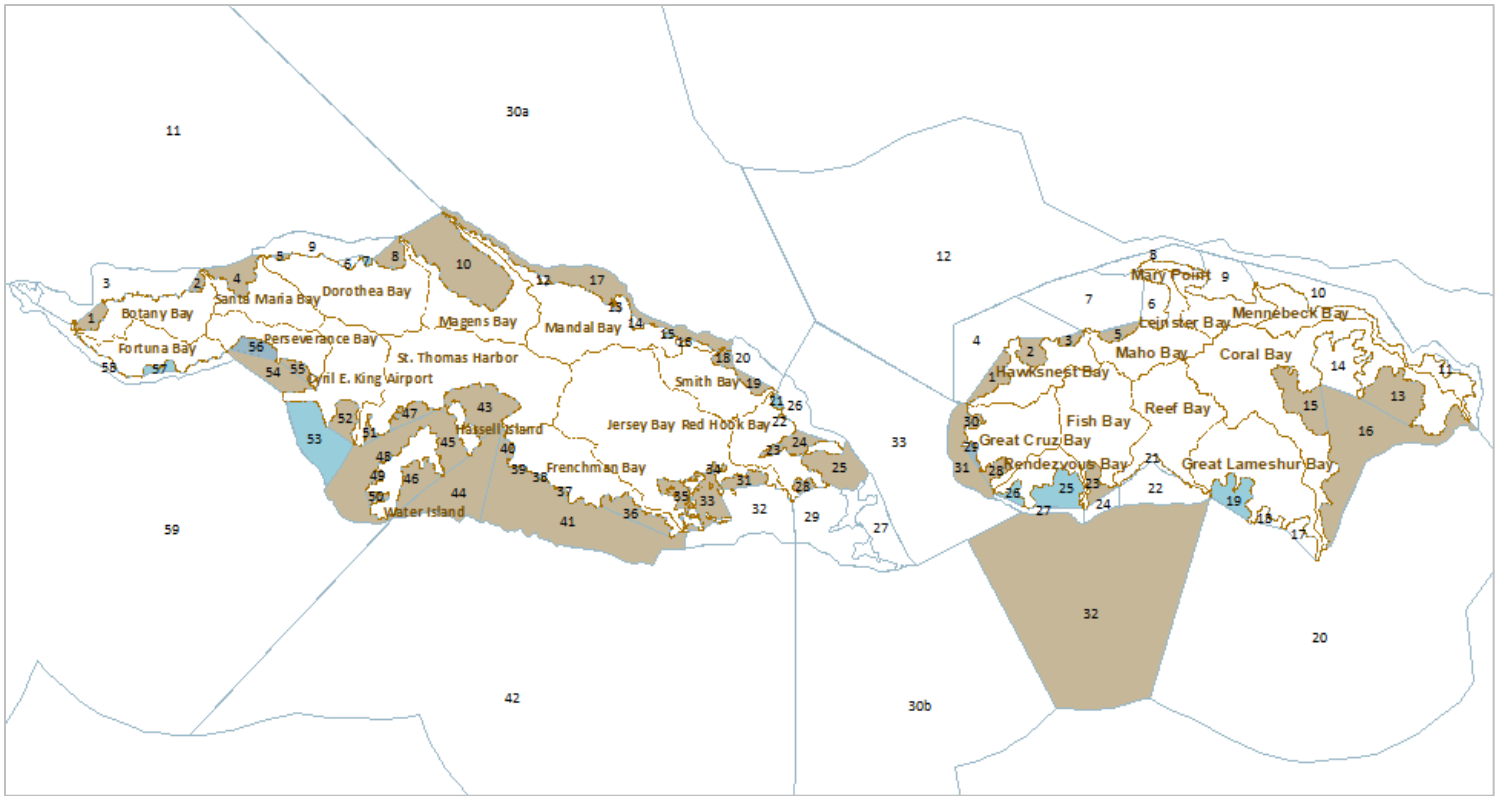

Figure 3.1 Impaired 305(b) and 303(d) assessment units and corresponding watersheds from the 2020 USVI Integrated Waters Report. Waters shaded in brown are currently impaired.

The 303(d) list of impaired waters is organized by assessment units and identifies waters that have an established Total Maximum Daily Load (TMDL). A TMDL establishes a target for how much of a pollutant can be discharged to a waterbody without causing an impairment. Since some of the impairments are attributable to land development, it is important to know which watershed your site is part of, and which pollutants you should focus on minimizing through your project. In the case of new development, you'll need to avoid adding more pollutants to already impaired systems. For redevelopment activities, you have an opportunity to improve conditions and help contribute to reductions of existing pollutant loads. In addition, several of the USVI watersheds have been studied and watershed management plans have been created to help improve flooding and identify opportunities to improve water quality conditions. Perhaps your project can be part of the solution!

To properly evaluate how the watershed context may influence site design and stormwater management planning at your site:

1. Identify the watershed your site is in and how rainfall on your site is carried downhill to the nearest receiving waterbody.
2. Contact DPNR to determine if your watershed/downstream waters are impaired by a particular pollutant, if there is a TMDL, or if a watershed management plan has been completed.
3. Avoid contributing additional stormwater or pollutants to any impaired waters. Design your stormwater management system to target removal of pollutants of concern.
4. Document watershed name, known impairments, and any pollutant reduction targets on permit applications, in drainage and pollution prevention reports, and on-site plans (notes or location maps).

### Environmental Justice

Environmental equity considerations should be part of the site evaluation process. EPA maintains a screening tool with mapping for various social vulnerabilities for communities around the county, including the USVI, at <https://ejscreen.epa.gov/mapper/>.

To elevate the consideration of social equity issues relevant to you project, designers should:

1. Review mappers or census information to proactively determine if a disadvantaged or vulnerable community is in the vicinity of their project site.
2. Provide additional opportunities for community input on project plans beyond required public hearings.
3. Consider incorporating additional features or mitigation/restoration to help address inequities (e.g., shade trees, offsite flood controls, accessibility).
4. Consult with the DPNR Division of Territorial Parks, the Department of Sports, Parks, and Recreation, Department of Public Works, or local organizations like the VI Trail Alliance to see if there are nearby opportunities to enhance connectivity, public access, or recreational opportunities with the adjacent community.

### Climate

Estimating the amount of precipitation your site is expected to receive is a necessary part of establishing runoff volume targets, adequately sizing stormwater control measures, and making design decisions related to landscaping and rainwater collection strategies. Much of the data used to evaluate precipitation amounts and frequencies is from NOAA. NOAA Atlas 14 Vol 3, specifically, covers Puerto Rico and the US Virgin Islands. It utilizes daily records collected over 50 years (on average) through 2004 to generate average rainfall depths for standard recurrence intervals (years) for typical storm durations (hours) at a dozen long-term stations (**Figure 3.2**). This data does not account for a changing climate and is scheduled to be updated to better reflect current conditions and predict future patterns. Additional rain monitoring stations are also coming online via the Community Collaborative Rain, Hail, and Snow Network (CoCoRaHs).

Until better data and predictive methods become readily available, designers should be conservative when estimating rainfall depths for standard design storms and durations. Consider using the NOAA Atlas 14 "Plus" approach, which better incorporates risk observed in current data by reflecting larger storm events. Steps include:

1. Go to the NOAA Precipitation Frequency Data Server (PFDS) <https://hdsc.nws.noaa.gov/pfds/>.

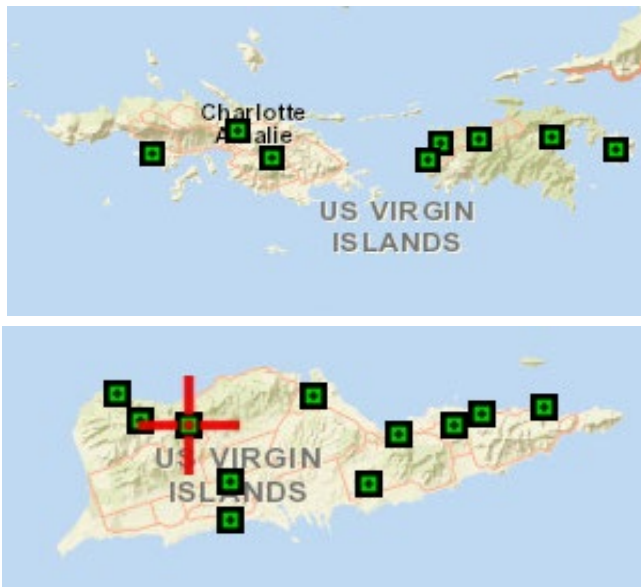

Figure 3.2. Weather stations in the USVI available from the NOAA Precipitation Frequency Data Server.

2. Select PR/VI on the map and zoom into the USVI. Either drag the crosshairs to your site. Alternatively, select a station by clicking “show stations” to the right of the map. Select the station that is most similar to your site (closest, similar elevation, leeward, etc.).
3. Scroll down the page to view tabular results. Select the design storms of interest (as dictated by the stormwater standards), based on a 24-hour duration, Type II distribution.
4. Obtain the depth of interest by using the 90<sup>th</sup> percentile confidence intervals (the range shown below the average) and multiplying the upper confidence limit by 0.9. For example (see 1-yr, 24-hr storm in **Figure 3.3**):

4.22 inches is the average depth for the 1-yr, 24-hr storm at the Fountain weather station on St. Croix. Confidence intervals span from 3.31 to 5.40 inches. Instead of using 4.22 inches, calculate rainfall depth using the upper confidence interval, as follows: 5.40 inches X 0.9= 4.86 inches

Use 4.86 inches instead of 4.22 inches as the 1-yr, 24-hr storm depth for calculating the runoff reduction target in Standard SW-2.

5. If a more robust analysis is needed for drainage designs, daily rainfall records can be downloaded from the NOAA National Centers for Environmental Information here: [www.ncei.noaa.gov/products/land-based-station/global-historical-climatology-network-daily](http://www.ncei.noaa.gov/products/land-based-station/global-historical-climatology-network-daily).



CoCoRaHS rain gauge at Lindquist Beach on St. Thomas.

6. Data from additional weather stations in the VI can also now be accessed through the CoCoRaHS website [www.cocorahs.org](http://www.cocorahs.org), but the period of record may be shorter. Refer to **Appendix B** for additional guidance on rainfall amounts and recommended frequency analyses.

Depending on the location of your site, vulnerability to flooding, storm surge, and sea level rise may also have design implications related to structure siting, floor elevations, etc. Designers should:

1. Utilize a 50-yr planning horizon for sea level rise and flood projections.
2. Look up the most updated FEMA flood maps to determine if your site is in a flood hazard area. You can access the most recent FIRM maps at <https://msc.fema.gov/portal/advanceSearch>. Select Virgin Islands from the drop-down list. To locate the map panel of interest, view the index map, which should be the first file listed (labeled “IND”).
3. Use NOAA’s Sea Level Rise mapper to evaluate if predicted inundation levels for sea level rise intersect with your site. Note that this data does not include coastal storm surge predictions. <https://coast.noaa.gov/dataviewer/#/lidar/search/where:ID=8999>.

- Recorded water levels and wind information can be obtained from <https://tidesandcurrents.noaa.gov> for several stations around the VI.
- For useful context at the outset of site design and planning, review the VI Coastal Resilience Evaluation and Siting Tool mapper to determine if your site is in the vicinity of a resilience hub, community exposure and threats (<https://resilientcoasts.org/#AnalyzeProjectSites>).

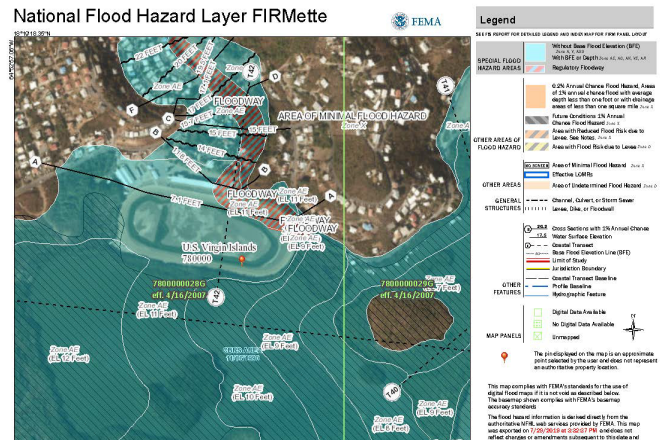

FEMA flood hazard map for the Clinton E Phipps Racetrack and surrounding area on St. Thomas.

PF tabular    PF graphical    Supplementary information    Print page

**PDS-based precipitation frequency estimates with 90% confidence intervals (in inches)<sup>1</sup>**

Duration	Average recurrence interval (years)									
	1	2	5	10	25	50	100	200	500	1000
5-min	0.475 (0.381-0.522)	0.564 (0.488-0.661)	0.688 (0.592-0.795)	0.779 (0.663-0.905)	0.896 (0.743-1.06)	0.988 (0.808-1.18)	1.08 (0.867-1.32)	1.17 (0.928-1.45)	1.29 (1.00-1.64)	1.39 (1.06-1.79)
10-min	0.649 (0.521-0.713)	0.771 (0.666-0.903)	0.940 (0.810-1.09)	1.06 (0.906-1.24)	1.22 (1.02-1.45)	1.35 (1.10-1.61)	1.47 (1.18-1.80)	1.60 (1.27-1.98)	1.77 (1.37-2.24)	1.89 (1.44-2.45)
15-min	0.833 (0.669-0.915)	0.990 (0.855-1.16)	1.21 (1.04-1.39)	1.37 (1.16-1.59)	1.57 (1.30-1.86)	1.73 (1.42-2.07)	1.89 (1.52-2.31)	2.05 (1.63-2.54)	2.27 (1.76-2.87)	2.43 (1.85-3.15)
30-min	1.33 (1.07-1.46)	1.58 (1.37-1.86)	1.93 (1.66-2.23)	2.19 (1.86-2.54)	2.52 (2.09-2.98)	2.77 (2.27-3.31)	3.03 (2.44-3.69)	3.29 (2.61-4.06)	3.63 (2.81-4.60)	3.89 (2.96-5.04)
60-min	1.98 (1.59-2.17)	2.35 (2.03-2.75)	2.87 (2.47-3.31)	3.25 (2.76-3.77)	3.73 (3.10-4.42)	4.12 (3.36-4.91)	4.50 (3.61-5.48)	4.88 (3.87-6.02)	5.39 (4.17-6.82)	5.77 (4.40-7.48)
2-hr	2.36 (1.93-2.70)	2.91 (2.48-3.47)	3.70 (3.12-4.39)	4.33 (3.58-5.17)	5.18 (4.15-6.34)	5.86 (4.59-7.25)	6.54 (5.00-8.32)	7.25 (5.44-9.46)	8.21 (5.97-11.1)	8.97 (6.38-12.5)
3-hr	2.56 (2.17-3.05)	3.31 (2.82-3.95)	4.22 (3.56-4.98)	4.94 (4.06-5.94)	5.92 (4.76-7.25)	6.71 (5.27-8.28)	7.50 (5.78-9.46)	8.32 (6.30-10.8)	9.43 (6.93-12.6)	10.3 (7.42-14.1)
6-hr	3.08 (2.56-3.77)	4.08 (3.37-4.99)	5.06 (4.07-6.38)	6.11 (4.84-7.57)	8.61 (6.53-10.9)	10.1 (7.43-13.0)	11.6 (8.28-15.5)	13.2 (9.20-18.2)	15.5 (10.3-22.2)	17.4 (11.2-25.7)
12-hr	3.73 (2.99-4.70)	5.06 (4.07-6.38)	6.11 (4.84-7.57)	7.22 (5.53-9.28)	12.2 (9.15-15.8)	14.6 (10.3-19.3)	17.1 (11.6-23.5)	19.8 (13.0-28.2)	23.8 (14.8-35.7)	27.0 (16.3-42.5)
24-hr	4.22 (3.31-5.40)	5.75 (4.51-7.35)	7.06 (5.44-9.28)	8.49 (6.41-11.1)	12.9 (9.15-18.7)	18.1 (13.7-22.5)	21.6 (16.1-28.8)	25.4 (18.8-31.6)	31.1 (22.6-38.7)	35.8 (25.7-44.7)
2-day	6.4 (4.7-8.6)	8.98 (6.7-11.9)	11.1 (8.1-15.1)	13.3 (9.7-18.4)	19.3 (14.2-25.4)	26.9 (19.9-36.2)	31.6 (23.5-42.1)	37.7 (28.4-50.1)	46.6 (34.4-62.1)	52.6 (39.4-70.1)
3-day	7.9 (5.7-10.6)	10.9 (7.9-15.1)	13.3 (9.7-18.4)	16.7 (12.3-22.6)	23.3 (17.4-30.8)	31.6 (23.5-42.1)	37.7 (28.4-50.1)	46.6 (34.4-62.1)	52.6 (39.4-70.1)	58.6 (44.4-77.1)
4-day	8.7 (6.4-11.4)	11.9 (8.7-15.9)	14.4 (10.6-19.4)	18.0 (13.3-24.1)	25.0 (18.7-32.7)	33.3 (25.2-43.5)	39.4 (29.9-51.4)	47.4 (36.3-61.4)	54.4 (41.4-71.4)	60.4 (46.4-78.4)
7-day	9.8 (7.4-12.8)	13.3 (9.9-17.7)	16.0 (11.9-21.1)	20.5 (15.7-25.8)	28.2 (21.7-36.3)	37.7 (28.4-50.1)	46.6 (34.4-62.1)	54.4 (41.4-71.4)	60.4 (46.4-78.4)	66.4 (51.4-85.4)
10-day	10.7 (8.1-14.1)	14.4 (10.6-19.4)	17.3 (12.9-22.7)	22.1 (16.7-29.1)	29.9 (22.9-39.0)	39.4 (29.9-51.4)	47.4 (36.3-61.4)	54.4 (41.4-71.4)	60.4 (46.4-78.4)	66.4 (51.4-85.4)
20-day	11.6 (8.7-15.5)	15.5 (11.4-20.6)	18.6 (13.9-24.9)	23.6 (17.9-31.3)	31.6 (24.5-40.7)	41.1 (31.6-53.6)	49.1 (37.9-64.1)	57.1 (44.9-75.1)	63.1 (49.9-82.3)	69.1 (54.9-91.3)
30-day	12.4 (9.2-16.4)	16.4 (12.2-21.6)	19.6 (14.7-26.5)	24.6 (18.7-32.7)	32.6 (25.2-43.5)	42.1 (32.6-55.6)	49.1 (37.9-64.1)	57.1 (44.9-75.1)	63.1 (49.9-82.3)	69.1 (54.9-91.3)
45-day	13.4 (10.1-17.3)	17.3 (13.1-22.7)	20.6 (15.5-27.5)	25.6 (19.6-33.6)	33.6 (26.2-43.0)	43.1 (33.6-56.1)	50.1 (39.0-65.1)	58.1 (45.9-77.1)	64.1 (50.9-84.3)	70.1 (55.9-93.3)
60-day	15.7 (11.7-19.7)	20.2 (15.5-26.9)	23.6 (18.4-30.8)	29.3 (22.9-39.0)	38.4 (29.9-51.4)	48.1 (37.9-64.1)	56.1 (44.9-75.1)	64.1 (50.9-84.3)	70.1 (55.9-93.3)	76.1 (61.9-100.3)

<sup>1</sup> Precipitation frequency (PF) estimates in this table are based on frequency analysis of partial duration series (PDS). Numbers in parenthesis are PF estimates at lower and upper bounds of the 90% confidence interval. The probability that precipitation frequency estimates (for a given duration and average recurrence interval) will be greater than the upper bound (or less than the lower bound) is 5%. Estimates at upper bounds are not checked against probable maximum precipitation (PMP) estimates and may be higher than currently valid PMP values. Please refer to NOAA Atlas 14 document for more information.

Figure 3.3 Tabular results for Fountain weather station on STX. Inset showing upper confidence interval used in NOAA Atlas 14 "Plus" calculation for the 90<sup>th</sup> percentile confidence interval.



## Soils

Most of the land on St. John, St. Thomas, and the north shore of St. Croix is steep and very susceptible to soil erosion and sediment loss. The soil layer can be very thin in sloped areas, overlaying fractured bedrock. Thicker alluvial deposits can be found in valleys and flatter areas near the coast. Given the limited flat land in the VI (much of that subject to flooding), development on steeper upland areas is inevitable. One of the first steps to minimize problems involving land use development is to know if the soils are appropriate for the intended use. Soil information can be obtained through existing references or by site investigations.

### NRCS Soil Survey

Web-based and digital copies of the *Soil Survey of the Virgin Islands* can be accessed through NRCS at [www.nrcs.usda.gov/wps/portal/nrcs/main/pr/soils/surveys/](http://www.nrcs.usda.gov/wps/portal/nrcs/main/pr/soils/surveys/). The Soil Survey is a basic inventory of the soil resources of the islands. The survey includes soil maps, descriptions, and interpretations. Soil maps depict soil boundaries and other features. The Soil Survey describes the characteristics and properties of each kind of soil in the Virgin Islands, including soil texture (sand, silt or clay), slope, depth, erodibility, permeability, degree of wetness, and other information useful to land developers. It can be used as a tool in determining soil limitations for many urban uses and in selecting sites and designing structures to minimize environmental and soil-related problems.

Soils are rated according to their limitations for a given use. These limitations are described as either slight, moderate, or severe. Soils with severe limitations (e.g., flooding, high shrink-swell potential, high erodibility, very steep slopes, shallow or stony soils, and excessively dry climate) will require careful consideration since the cost of overcoming a limitation may be high. Problems resulting from limitations include collapsing roadbeds, flooded buildings, cracking and failing building foundations, malfunctioning septic systems, excessive erosion, and sedimentation damage. Measures to overcome these problems are easier to identify in the planning phase.

One of the most helpful soil parameters for stormwater planning is the Hydrologic Soils Group (HSG) classification that characterizes soils as A, B, C, or D (or some combination). HSG indicates the minimum

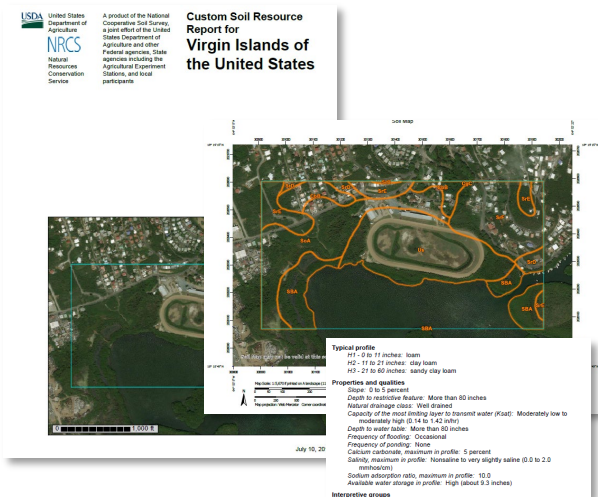

Custom soil resources reports can be generated for specific sites from the NRCS soil survey website.

rate of infiltration obtained for bare soil after prolonged wetting. The infiltration rate is the rate that water enters the soil at the surface (does not account for slope). HSG also indicates the transmission rate—the rate water moves within the soil. HSG A and B soils are generally considered good for infiltration, and C and D, typically, are not. **Table 3.1** summarizes general characteristics of the four HSG classes.

Table 3.1 General characteristics of the Hydrologic Soil Groups

HSG	Infiltration Rate (wetted)	Soil Descriptor	Soil Textures	Water Transmission rate
A	low runoff potential and high infiltration rates	deep, well to excessively drained sand or gravel	sand, loamy sand, or sandy loam	high (>0.30 in/hr).
B	moderate infiltration rates	mod. deep to deep; mod. well to well drained soils; mod. fine to mod. coarse texture	silty loam, or loam	moderate (0.15-0.30 in/hr).
C	low infiltration rates	Layer that impedes downward flow of water; moderately fine to fine texture	sandy clay loam	low (0.05-0.15 in/hr)
D	high runoff potential and very low infiltration rates	high swelling potential; permanent high water table; claypan or clay surface layer; shallow soils over impervious material	clay loam, silty clay loam, sandy clay, silty clay, or clay	very low (0-0.05 in/hr).

Some D soils are classified due to high water tables that create a problem. These soils may be given a dual classification (e.g., A/D) to reflect the group under both drained and undrained conditions. Disturbed urban soils may no longer reflect the assigned HSG. A new HSG can be assigned based on a textural assessment in the field.

If appropriate, the Rawls table can be consulted to assign a standard design infiltration rate for various soil textures (**Table 3.2**). These rates are derived from a national CONUS database. While potentially limited in its application on the thin, gravelly soils prevalent in the VI, assumed design rates could provide at least a preliminary estimate to inform early stormwater management design.

*Table 3.2 Design Infiltration Rates for Stormwater Practices (adapted from Rawls et. al, 1982).*

Soil Texture	Design Infiltration Rate (in/hr)	Hydrologic Soil Group
Sand	8.27	A
Loamy Sand	2.41	A
Sandy Loam	1.02	B
Loam	0.52	B
Silt Loam	0.27	C
Sandy Clay	0.17	C
Clay Loam	0.09	D
Silty Clay	0.06	D
Sandy Clay	0.05	D
Silty Clay	0.04	D
Clay	0.02	D

If you believe your site has a higher infiltration rate than what is shown in the Rawls table, then you can do a field test for in situ infiltration rates (see methods below). Any field rates must apply safety factor or 2 to account for clogging over time.

For example, sand has Rawls value of 8.27 inches per hour.

Field tests indicate a rate as high as 30 inches per hour.

The maximum design rate that can be applied is  $30/2 = 15$  inches/hr to incorporate the safety factor.

**Table 3.3** provides information on HSG, texture, soil erodibility, and soil loss tolerance for common soils found in the VI. Further information on the VI soils can be obtained from the USDA Natural Resources Conservation Service, UVI Cooperative Extension Service, or VI Department of Agriculture.

In previous editions of the Environmental Protection Handbook, guidance was provided on how to predict soil loss from sheet and rill erosion using the anticipated Revised Universal Soil Loss Equation (RUSLE). For this equation, soil erodibility factors (K) and loss tolerance (T) are used. The RUSLE equation is widely used for watershed and agricultural models but is less often applied to site level post-construction stormwater design. This version of the EPH uses a runoff volume-based approach to construction site erosion and sediment control. However, if an erosion-based approach is needed, RUSLE guidance can be accessed from the U.S. Department of Agriculture at <https://www.ars.usda.gov/>.

### Onsite Soil Evaluations

Often for stormwater management, understanding actual water table elevations and the soil's potential to infiltrate at specific locations and depths is critical. While a rough idea can be obtained from the soil survey, an onsite soil evaluation is more informative. Soil test pits, borings, permeability tests, and textural analysis may be appropriate.

Test pits are used to measure depth to groundwater, and allow for the evaluation of soil horizons, textures, and hydromorphic features. They are dug with a backhoe and are generally large enough for a person to stand in (~2ft X 5 ft, 5-6 feet deep). **Figure 3.4** shows a schematic of a deeper hole test pit with access shelf. Test pits require a trained soil evaluator who can identify soil horizons, textures, and hydrologic features. In some cases, a less intrusive soil boring can be used in tight spaces where a larger pit is not feasible.

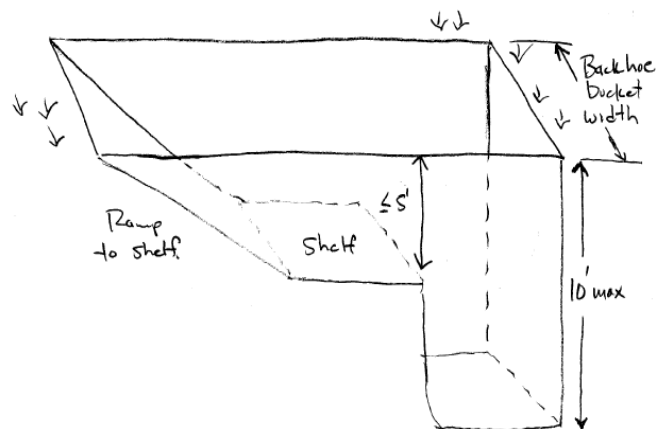

*Figure 3.4. Typical deep hole test pit*

Table 3.3. Soil Erodibility Factors (K), Soil Loss Tolerance Factors (T), and Hydrologic Soil Groups of the A, B and C Horizons, Virgin Islands Soil Series (USDA-NRCS, 1995).

Map Unit Symbol	Component Name	Surface Texture*	Percent of Map Unit	Hydrologic Group	Kf	T**	Rock Cover %
AcD	ANNABERG	GR-L	60	D	.12	1	30
AcD	CRAMER	GR-CL	20	C	.08	2	25
AcE	ANNABERG	GR-L	60	D	.12	1	30
AcE	CRAMER	GR-CL	20	C	.08	2	25
AcF	ANNABERG	GR-L	60	D	.12	1	30
AcF	CRAMER	GR-CL	20	C	.08	2	25
AcG	ANNABERG	GR-L	60	D	.12	1	30
AcG	CRAMER	GR-CL	20	C	.08	2	25
AmD	ANNABERG	GR-L	50	D	.12	1	30
AmD	MAHO BAY	GR-L	30	D	.22	2	15
AmE	ANNABERG	GR-L	50	D	.12	1	30
AmE	MAHO BAY	GR-L	30	D	.22	2	15
AmF	ANNABERG	GR-L	50	D	.12	1	30
AmF	MAHO BAY	GR-L	30	D	.22	2	15
AmG	ANNABERG	GR-L	50	D	.12	1	30
AmG	MAHO BAY	GR-L	30	D	.22	2	15
AqA	AQUENTS	VAR	90	D		5	NO DATA
ArB	ARAWAK	GR-L	85	B	.12	2	25
ArC	ARAWAK	GR-L	85	B	.12	2	25
ArD	ARAWAK	GR-L	85	B	.12	2	25
ArE	ARAWAK	GR-L	85	B	.12	2	25
ArF	ARAWAK	GR-L	85	B	.12	2	25
BrB	ROCK OUTCROP	UWB	90	D			NO DATA
BsB	BEACHES	S	90	D		5	10
BtB	BEACHES	STX-S	90	D		5	NO DATA
CaA	CARIB	CL	85	D	.26	5	5
CbB	CINNAMON BAY	L	85	B		5	5
CqC	CINNAMON BAY	GR-L	85	B	.17	5	10
CvC	CRAMER	CL	50	C	.08	2	15
CvC	VICTORY	L	30	B	.22	3	20
CvD	CRAMER	CL	50	C	.08	2	15
CvD	VICTORY	L	30	B	.22	3	20
CvE	CRAMER	CL	50	C	.08	2	15
CvE	VICTORY	L	30	B	.22	3	20
CvF	CRAMER	CL	50	C	.08	2	15
CvF	VICTORY	L	40	B	.22	3	20
DoE	DOROTHEA	CL	80	C	.17	5	10
DoE	SUSANNABERG	CL	15	D	.12	2	30
DoF	DOROTHEA	CL	80	C	.17	5	10
DoF	SUSANNABERG	CL	15	D	.12	2	30
DoG	DOROTHEA	CL	80	C	.17	5	10
DoG	SUSANNABERG	CL	15	D	.12	2	30
FsD	FREDRIKSDAL	GRV-CL	50	D	.22	1	35
FsD	SUSANNABERG	CL	30	D	.12	2	30
FsE	FREDRIKSDAL	GRV-CL	50	D	.22	1	35
FsE	SUSANNABERG	CL	30	D	.12	2	30
FsF	FREDRIKSDAL	GRV-CL	50	D	.22	1	35
FsF	SUSANNABERG	CL	30	D	.12	2	30
FsG	FREDRIKSDAL	GRV-CL	50	D	.22	1	35
FsG	SUSANNABERG	CL	30	D	.12	2	30

Map Unit Symbol	Component Name	Surface Texture*	Percent of Map Unit	Hydrologic Group	Kf	T**	Rock Cover %
GyA	GLYNN	GR-L	85	C	.20	5	10
GyB	GLYNN	GR-L	85	C	.20	5	10
GyC	GLYNN	GR-L	85	C	.20	5	10
HeA	HESELBERG	C	85	D	.05	2	0
HeB	HESELBERG	C	85	D	.05	2	0
HeC	HESELBERG	C	85	D	.05	2	0
HgA	HOGENSBERG	CL	85	D	.26	5	0
HgB	HOGENSBERG	CL	85	D	.26	5	0
HgC	HOGENSBERG	CL	85	D	.26	5	0
JaB	JAUCAS	S	85	A	.08	5	0
JsD	JEALOUSY	GR-CL	50	C	.15	3	10
JsD	SOUTHGATE	GR-L	30	D	.22	1	25
JSE	JEALOUSY	GR-CL	50	C	.15	3	10
JSE	SOUTHGATE	GR-L	30	D	.22	1	25
JsF	JEALOUSY	GR-CL	50	C	.17	3	10
JsF	SOUTHGATE	GR-L	30	D	.22	1	25
LmC	LAMESHUR	GR-SL	85	A	.12	5	55
PaB	PARASOL	CL	85	B	.15	5	0
PaC	PARASOL	CL	85	B	.15	5	0
Pt	PITS	UWB	90				NO DATA
RdB	REDHOOK	STX-S	85	A	.08	5	65
SaA	SALT FLATS	SICL	90	D		5	No DATA
SbA	SANDY POINT	SCL	50	D	.20	5	0
SbA	SUGAR BEACH	MUCK	40	D		3	0
SiA	SION	C	85	B	.05	4	5
SiB	SION	C	85	B	.05	4	5
SoA	SOLITUDE	GR-FSL	85	D	.20	5	20
SrD	SOUTHGATE	GRV-L	45	D	.22	1	30
SrD	ROCK OUTCROP	UWS	40	D			No DATA
SrE	SOUTHGATE	GRV-L	45	D	.22	1	30
SrE	ROCK OUTCROP	UWB	40	D			No DATA
SrF	SOUTHGATE	GRV-L	45	D	.22	1	30
SrF	ROCK OUTCROP	UWB	40	D			No DATA
SrG	SOUTHGATE	GRV-L	45	D	.22	1	30
SrG	ROCK OUTCROP	UWB	40	D			NO DATA
UbD	URBAN LAND	VAR	90				No DATA
UcC	URBAN LAND	VAR	80				No DATA
UcC	CINNAMON BAY	L	15	B	.17	5	5
UqC	URBAN LAND	VAR	80				NO DATA
UqC	GLYNN	GR-L	15	C	.20	5	10
VsC	VICTORY	L	45	B	.22	3	20
VsC	SOUTHGATE	GR-L	40	D	.22	1	25
VsD	VICTORY	L	45	B	.22	3	20
VsD	SOUTHGATE	GR-L	40	D	.22	1	25
VsE	VICTORY	L	45	B	.22	3	20
VsE	SOUTHGATE	GR-L	40	D	.22	1	25
VsF	VICTORY	L	45	B	.22	3	20
VsF	SOUTHGATE	GR-L	40	D	.22	1	25

\* texture abbreviations are GR=gravelly, GRV=very gravelly, L=loam, FSL=fine loamy sand, C=clay, CL= clay loam, S=sand, SI=silt, SICL=silty clay loam, SCL= sandy clay loam, SIC= silty clay, MUCK=muck, UWB=unweathered bedrock, VAR=variable

\*\* The soil loss tolerance or permissible soil loss ("T" factor) is expressed in tons/acre/year.



*Test pit dug at the Smith Bay ballfield on St. Thomas to measure depth to groundwater and evaluate the soil profile and texture to determine infiltration potential.*

Field testing of hydraulic conductivity or infiltration rates of in situ soils may be needed for engineered stormwater facilities that rely on infiltration. Testing should generally be completed using the following procedures:

1. Saturated hydraulic conductivity rates should be determined in the field at the actual location and depth (bottom elevation) of the proposed practice.
2. The field method should consist of a constant or falling head permeability test performed in accordance with ASTM D5126-90 "Standard Guide for Comparison of Field Methods for Determining Hydraulic Conductivity in the Vadose Zone."
3. The Guelph Permeameter, the Amoozometer, and a falling head permeameter are all acceptable equipment to conduct the test. A double ring infiltrometer is not recommended for determining hydraulic conductivity in limestone deposits because of the difficulty in maintaining a seal in the shallower soils due to the presence of rock fragments.
4. Standard percolation testing procedures used for designing septic systems are not an acceptable method for determining design rates for structural stormwater practices.

A simpler approach to determine relative infiltration rates for rain garden installations can be used, as follows:



*NRCS staff measuring infiltration rates using a single ring infiltrometer at a potential rain garden location on St. Croix.*

1. Dig a small hole with a shovel in the area where you expect to build your rain garden. Site the hole where you think the middle of your garden will be. Excavate to the anticipated depth of the rain garden (6, 9, or 12 inches). Set the spoils from your hole aside.
2. If you run into a hard layer that cannot be penetrated with a shovel or groundwater is observed, then stop. Rain gardens should not be sited over high water tables, so your site is inappropriate. If your hard surface is rock, you may also want to move the rain garden to another location.
3. Fill the hole with water to just below the rim. Record the exact time you stop filling the hole and the time it drains completely.
4. Refill the hole again with water and repeat step 3 two more times. The third test will give you the best measure of how quickly your soil absorbs water when it is fully saturated.
5. Divide the distance the water dropped (measured from the rim to top of standing water) by the amount of time it took for it to drop. For example, if the water dropped 1 inch in 2 hours, then 1 divided by 2 equals 0.5 inch per hour of infiltration. Rates between 0.5 and 2 in/hr are great for a rain garden. When rates are faster than 2 in/hr, the rain garden will require more drought-tolerant plants

since most of the water will be absorbed at the inflow points. Infiltration rates less than 0.5 in/hr suggest poorly drained soils, high water tables, or surface bedrock—the raingarden may not function properly.

To determine the texture and consistency of soils, conduct a “ribbon” test (if soils are conducive to collection):

1. Take a handful of the soil excavated from your infiltration test. Mush it in your hands and remove bits of rock and organic matter.
2. Apply a small amount of water to the soil and rub it between your thumb and finger. Do not oversaturate (i.e., runny mud). You might feel stickiness, grittiness or smoothness. The grittier the feel, the more sand. The slicker the soil, the more clay. Smooth soils can indicate a fine silt or loam. Discard.
3. Using another sample, wet it until you can form a ball with the soil in your palm. If you cannot get the ball to hold together, then your soil is very sandy.
4. Knead the soil together between your thumb and fingers. Again, remove any obvious organic matter or rocks and form a ribbon with the soil. As you build the ribbon, it will either hold together or break off. If the soil breaks quickly in the process, then it has a high sand content. If the ribbon forms quickly and stays strong, it has more clay.

From a stormwater planning perspective, soils with a high sand content will drain quickly and may be suitable for infiltration practices where runoff can be adequately pre-treated. Vegetated stormwater facilities might need to have some soil amendments added to increase moisture holding ability during the dry periods. Alternatively, you may want to plant more drought tolerant plants that are more characteristic to the plants found in VI’s sandy soils.

Soils with a high clay content will drain slowly or sometimes, not at all. These areas may not be suitable for infiltration but could be ideal for rainwater harvesting or vegetated treatment practices. For vegetated surface practices, clayey soils will need organic matter added to increase infiltration. Conversely, you may need to plan for a larger surface footprint (doubling the size for example) or

constructing a deeper basin to hold more water. With high clay soils, plan for plants that will be flooded more often and for longer periods. These plants may still need to be irrigated if they are not tolerant of drought conditions.

See **Chapter 5** for design guidance for post-construction stormwater practices.



*This ribbon test indicates a higher clay content which means that assumed design infiltration rate from Rawls table are less than 0.1 in/hr.*

### Other Environmental Factors

DPNR does not currently host an online mapping tool for natural resource information, such as regulated environmental protection areas, wellhead protection, guts, wetlands, critical habitats, or sensitive species distributions. Typically, resource delineations and assessments will be conducted as part of Environmental Assessment Reports that are required for most permitting. Designers will likely need to:

- Hire a local biologist with a background in the native ecosystems of the islands to conduct the environmental site assessment. In some cases, this may include in-water evaluations of benthic communities in addition to terrestrial inventories.
- Evaluate the quality of forests and identify individual trees that are greater than 6” in

diameter. Trees should be shown on site plans. The removal of trees should be minimized and quantified per Standard (ESC-3). If mangroves are on your site, cutting of these trees is prohibited.

- Include guts, wetlands, vegetated buffer, and shoreline setbacks on site topographic maps and existing condition plans (ESC-2). Find out what the setback requirements are for clearing and construction (e.g., clearing of vegetation adjacent to the gut is prohibited). It is possible that in addition to territorial requirements, proposed alterations to existing guts and wetlands will need approval from US Army Corps of Engineers if they are considered jurisdictional under federal wetlands protection regulations.
- Ensure wetland delineations follow the methods outlined by the Army Corps of Engineers for the Caribbean region that considers wetland vegetation, hydrology, and soils in boundary determinations (document accessible at <https://apps.dtic.mil/sti/citations/tr/ADA543979>).
- Call the DPNR Division of Fish and Wildlife to determine if any priority habitat or wildlife action strategies could be partially met through onsite open space protection or restoration.

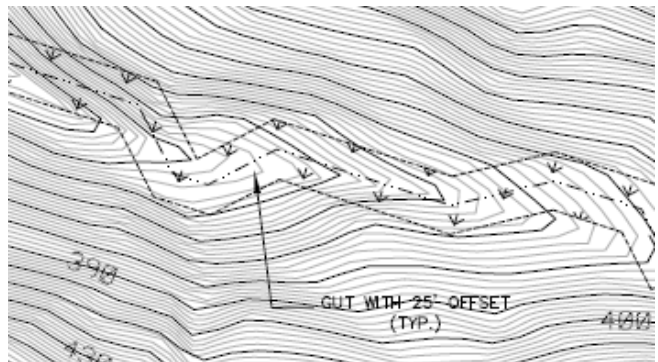

Example of gut setback include on existing condition plan from a proposed resort development on St. Croix.



### Contributing Drainage Areas

Regardless of the size and topography of a site, how rainfall enters, exists, and flows through the site is critical to understand early in site evaluation. What drains onto the site from adjacent, uphill properties and does it contribute to flooding issues? What are the existing flow paths through the site and can the site layout work around them? Where are the current discharge points, what is their condition, and how large is the contributing drainage area? The contributing drainage area, rainfall, and surface conditions (e.g., slope, soil, and land cover type) will all factor into calculating how much surface runoff is currently generated on site, and how that runoff volume is expected to change under proposed conditions. Drainage area is a key factor in estimating the size of culvert pipes and of stormwater control measures (**Figure 3.5**). Simple estimations can be made for how much impervious cover will contribute runoff to a rain garden, but modeling (e.g., HydroCAD or similar) may be needed to design more complex engineered practices (see **Chapter 5** for design



Figure 3.5. The 2,000 SF of impervious cover draining to a rain garden in Hope and Carton Hills, St. Croix (top) and 15-acre drainage area to a restored culvert and trench drain at Independent Boatyard on St. Thomas (bottom).

information). Depending on the location and complexity of your project, you may need to calculate runoff volume and flow at various locations on the site.

### Applicable Permits

Beyond the conditions previously mentioned, you'll need to know which territorial and federal permits will be required for your site and what stormwater management documentation will need to be provided with permit applications. While not a comprehensive list, you can start by contacting the VI Department of Planning and Natural Resources, as suggested below:

- Division of Permits—for Earth change and construction permits (single lot and major), building permit applications, and Flood Hazard permits. <https://dpr.vi.gov/division-of-permits/forms-applications/>
- Coastal Zone Management (CZM) office if your site is in Tier I—Major or Minor Land and/or Water Applications; Repair and Maintenance Form (<https://dpr.vi.gov/coastal-zone-management/forms-applications/>). They will advise you on if your coastal project will trigger Army Corps of Engineers or other federal level environmental review (e.g., NOAA National Marine Fisheries Service).
- Division of Environmental Protection (DEP) if your project site is in Tier II or subject to TPDES and Multi-sector general permits (mostly for large commercial, hotel, or industrial sites) or other water pollution permits (e.g., underground storage tanks, groundwater permits, and boring requests. <https://dpr.vi.gov/environmental-protection/forms-applications/>
- The State Historic Preservation Office—If there is potential to trigger archeological evaluations and how this might impact your stormwater and site planning options. <https://dpr.vi.gov/state-historic-preservation-office/forms-applications/>
- To conduct maintenance and grading on a private, unpaved road, a permit is required from CZM or DEP.

New driveway permits are issued by the Department of Public Works. The applicant will need to show that driveway culverts are designed appropriately and that drainage from the site will not negatively impact public roads or contribute to downhill flooding.

## 3.2 RUNOFF REDUCTION USING LID

Low impact development (LID) is one of the most important tools for stormwater management. LID is a comprehensive approach to managing stormwater that fully integrates with site design to minimize the hydrologic impacts of development. The objective of stormwater managers has evolved over the years from a limited focus on peak flood controls, to water quality treatment, to replicating a site's natural hydrology. Reducing the volume of runoff generated and ultimately discharged off site has become the new focus of the modern stormwater paradigm (refer back to **Figure 1.9**).

This new approach to stormwater management strives to achieve several goals:

- The preservation and use of natural systems to achieve stormwater management objectives to the extent feasible.
- The reduction of runoff and mimicking of predevelopment site hydrology by using site planning and design strategies to store, infiltrate, evaporate, and detain runoff as close as possible to the point where precipitation reaches the ground.
- The use of smaller, cost-effective treatment practices located throughout the development site rather than reliance on one or more centralized facilities located at the bottom of drainage areas.

Design strategies include reducing or disconnecting impervious cover; using vegetation to absorb runoff; and diverting remaining surface flows into smaller practices for filtering, recharge, and reuse. Larger storms are not easily managed on site; therefore, keeping infrastructure out of the way and providing safe conveyance off-site may still be the best approach for handling large storm events. This is particularly true as climate change predictions for the VI indicate less annual rainfall, but more frequent and intense storms.

Stormwater Standard #SW-2 Runoff Reduction, requires an LID approach to be used to minimize the impact of development on hydrology and watershed health. LID is an approach to land development that:

- 1) **Avoids** disturbance of existing vegetation, soils, and wetlands that are part of the nature stormwater system to the maximum extent



possible (e.g., minimizing canopy loss; exposure to erosion and flooding);

- 2) **Reduces** the amount of impervious cover and, thus, stormwater runoff generated in the first place through careful site planning and design techniques; and
- 3) **Manages** runoff that is generated through structural and non-structural practices that filter, recharge, reuse, or otherwise reduce runoff from the site.

SW-2 requires that sites contribute zero surface discharge from the 1-year, 24-hour Type II design storm. In other words, the entire runoff volume for this small-sized storm event must be reused, infiltrated, evaporated, and/or otherwise retained on site. This can be accomplished through a combination of site design and structural practices.

Common design strategies include:

- Preserve vegetated open space and natural areas that minimize the development footprint and prevent impacts to natural drainageways and wetlands.
- Prevent soil loss and compaction to retain as much infiltration capacity on site as possible.
- Create a multi-functional landscape for aesthetics and for stormwater. Your flowers can serve double duty—making your property attractive while providing evapotranspiration and pollutant uptake services.
- Minimize impervious surface to avoid excessive and unnecessary hardscapes that generate more runoff to ultimately manage.
- Disconnect runoff by breaking up drainage patterns with smaller, less complex practices distributed around the site to manage runoff close to the source and to provide redundancy in the stormwater system.

As green building standards and community resilience goals have become more interconnected, LID has grown popular in the U.S. and around the globe. Many jurisdictions require (or provide strong incentives for) the LID approach to stormwater management by restricting approved practices; establishing stringent pollutant removal standards; or setting impervious cover disconnection targets for new development, redevelopment, and retrofit activities. The US

Department of Defense has on-site retention standards for federal facilities that provide a strong incentive for LID designs. The VI has a long history of mandating cisterns for the capture and reuse of rooftop runoff for residences and businesses. Given the environmental and long-term financial benefits of LID, there is really no reason not to embrace this design approach. **Figures 3.6** and **3.7** are VI examples of LID design applications.

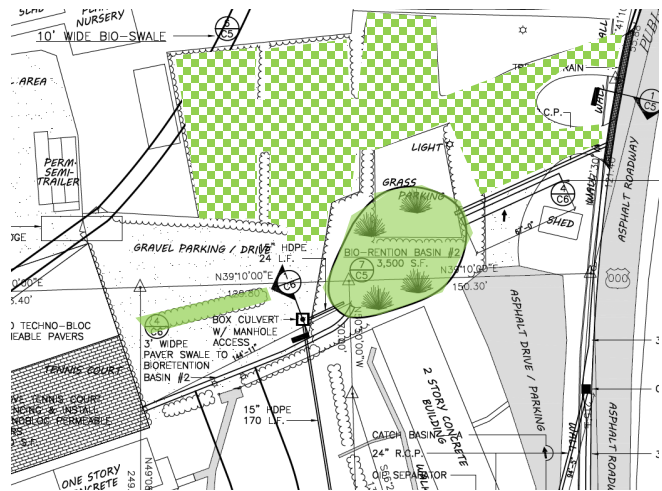

*Figure 3.6. Bolongo Bay, St. Thomas renovation plans included conversion of an existing gravel parking lot (considered impervious) to permeable pavers and the installation of several bioretention facilities integrated into the resort's landscaping.*



*Figure 3.7. The RT Park on St. Croix includes vegetated water quality swales and a large rainwater harvesting system below the parking lot used for irrigation, toilet flushing, and cooling tower recirculation.*

If Stormwater Standard SW-2 cannot be met, applicants will need to document hardships and the reason for their inability to use these design strategies or structural practices. **Appendix A** contains the Runoff Reduction Checklist that should be included to document the LID approach proposed or considered for the site.

For inspiration on methods to implement an LID approach to stormwater management in the VI, review Stormwater Management in Pacific and Caribbean Islands: A Practitioner’s Guide to Implementing LID (HW and CWP, 2014). A brief discussion on key design elements is provided below.

### Vegetated Open Space Preservation

The best way to minimize runoff is to preserve natural areas right from the start. Mature trees and undisturbed soils help to maintain the natural hydrology of the area. Open space can provide habitat, biological diversity, recreational benefits, windbreaks, privacy barriers, landscape aesthetics, noise buffer, and dust filtering benefits. Trees in particular offer rainfall interception, evapotranspiration, shading, and cooling benefits. Vegetation and wetlands left on a site also works as a filter to trap sediments and other pollutants. Natural vegetation preservation is particularly beneficial in or near floodplains, wetlands, guts, steep slopes, and other areas where erosion controls are difficult to install, and maintain.

Good design includes:

1. Designate priority areas for preservation prior to initial site layout. Areas should target mature trees, undisturbed soils, floodplains, guts, and wetland resources to promote infiltration, evapotranspiration, and stabilization of steep slopes, as well as natural flow paths.
2. Work roads and building footprints around natural features instead of fitting nature into your design plans (**Figure 3.8**).
3. Capitalize on the benefits provided by open space. Perhaps there are opportunities to achieve flexibility with other site design aspects (e.g., density) in exchange for preserving critical areas at a site. Some additional tax benefits may also be available if conservation restrictions are placed on these preserved areas.
4. Exceed minimum open space requirements prescribed by zoning.



Figure 3.8. Alternative site layout for eco resort on St. John focused on maintaining a 200ft or greater shoreline setback, limited clearing around proposed structures, and a drainage friendly road network.

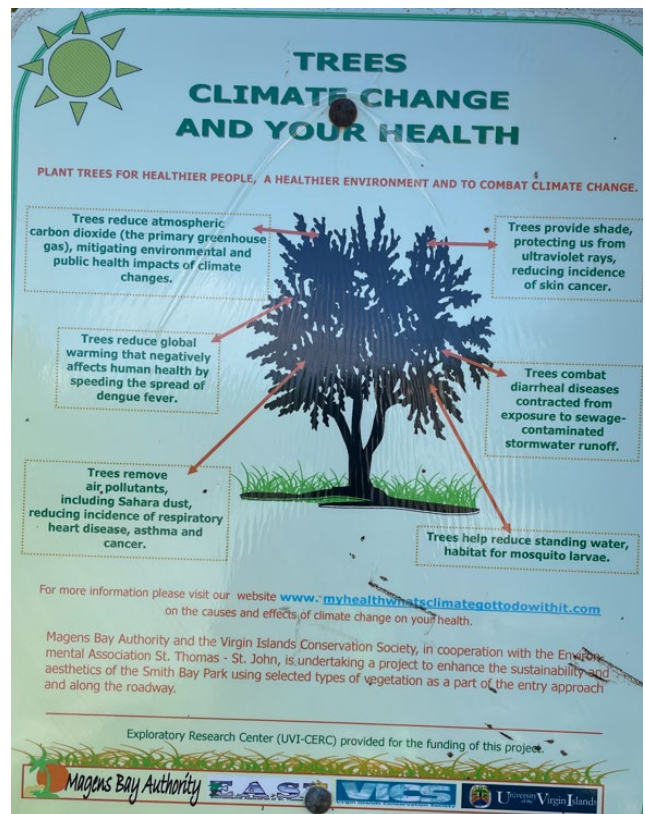

Signage posted by the Magens Bay Authority on St. Thomas outlining the many benefits of native trees.

Often areas of a construction site are unnecessarily cleared early in the process and the opportunity to retain valuable vegetation is lost. To achieve Stormwater Standards ESC-2 & 3, only those areas essential for construction activities should be cleared

(building, road/driveways, cistern and septic system footprints). Other areas should remain undisturbed, particularly critical areas such as those with steep slopes and/or highly erodible soils, or areas around guts, ponds or coastal waters. Clearing in a small structural envelope minimizes erosion potential, protects water quality, provides aesthetic benefits, and is cost-effective in the long term. Heavy equipment can ruin the topsoil through compaction and kill desirable plants. The proposed limits of land disturbance should be physically marked off to ensure that only the required land area is cleared. Hard-to-control plants like guinea grass, vines, tan-tan and casha can rapidly take over cleared areas. Hand-clearing preserves existing vegetation while removing unwanted plants. Good site clearing and stabilization approaches, including a few very progressive techniques:

- Site clearing by hand and leaving vegetation 1 ft tall/with roots to hold soils;
- limiting clearing and grading around building envelopes to 5 ft to allow existing vegetation to remain until the final landscaping is done; and
- keeping road layouts along the ridges as much as possible to minimize clearing and grading.

See **Chapter 4** for practices to protect natural areas prior to site disturbance.

### Soil Protection

Since soils are so shallow in the Virgin Islands, topsoil is a rare commodity and should be conserved. Heavy equipment can compact existing soil, making the natural flow of water into and through the soil more difficult. As little existing topsoil should be removed as possible. Where topsoil has been removed, soil should be stockpiled on the site so that it can be re-applied. Soil stockpiles must be temporarily seeded or covered with a tarp, mat or geotextile to prevent erosion. Compatibility of existing and imported topsoil should be checked to ensure maximum growth potential for the desired vegetation. The VI doesn't operate a composting facility, but private landowners, resorts, and others should investigate onsite composting alternatives for managing organic debris.

### Multi-functional Landscaping

Most sites have areas of vegetation or turf grass that serve as aesthetic landscaping, barriers between



*Drainage is directed into a parking median (top) and small taro rain garden between buildings (bottom).*

parking stalls and driving aisles, buffers between adjacent land uses, or recreational spaces. Many of these areas can also provide stormwater management benefits without compromising other functions or significantly increasing overall site maintenance costs. These vegetated areas should be designed as multi-functional landscapes integral to LID objectives. Remember, plants can absorb a tremendous amount of water, take up pollutants, and transpire water vapor back into the atmosphere. Roots help water infiltrate into the ground and provide surface area for microbes that can remove contaminants. Soils can filter the runoff, removing pollutants before infiltrating the groundwater. Reusing stormwater can reduce irrigation costs and increase plant survival—particularly if your site is on the dry side of the island or if you are limited in your vegetation options due to seasonal rainfall patterns. Existing open spaces can offer the ideal locations for cost-effective stormwater retrofits; in some cases, all you need is a shovel, some plants, and a few friends!

When designing the “green” space at a new development or retrofitting existing vegetated areas,

consider one of the following strategies for incorporating LID:

1. Integrate landscaping and stormwater management by incorporating BMPs in areas that are typically vegetated anyways such as road rights-of-way, medians, in parking lots, or in landscape beds. This can be applied to overly wide roads by doubling as traffic-calming measures or help achieve urban canopy program targets.
2. Use your land efficiently by creating showpiece stormwater attractions at your site entrance instead of the typical mounded landscaping.
3. Convert existing landscapes and turf areas into vegetated SCMs such as bioretention by taking advantage of existing low points and flow paths (See **Chapter 5**). Use simple diversion techniques to redirect runoff where needed (e.g., speed bumps, dips, trench drains).
4. Upgrade vegetation and soils by converting turf grass areas or high maintenance landscaping (i.e., requires fertilizers, pesticides, and irrigation) to native trees, shrubs, and grasses. Because native plants are less expensive than non-native and are more adapted to the VI climate, this switch will reduce the amount of water and maintenance needed. In addition, native plants (particularly trees) tend to have extensive canopy and root systems that can improve infiltration, take up nutrients, and intercept and evaporate more rainwater than a typical lawn.
5. Consult with local nurseries, landscape architects, or botanists on the best natives for your project. Jamaican caper, frangipani, orange man jack, pink cedar, sea grape, lignum vitae, turpentine tree, tyre palm, sabal palm, wild ferns, wild anthurium, and spider lily are common natives used in landscaping. Some plants are better for birds, insects, and aesthetics than others. If this is for stormwater practices, make sure they are drought tolerant (xeriscaping) and can tolerate highly variable water levels.

### Impervious Surface Diet

Parking lots, roads, rooftops, and other hardscapes take up a significant amount of the developed landscape. These impervious surfaces generate runoff when it rains, and the stormwater can pick up oils,



*The Jamaican Caper/Black Willow (Quadrelle cynophallaphora) and White Frangipani (Plumeria alba) are common native species recommended for landscaping.*

heavy metals, trash, and other contaminants. While rooftops are frequently used to harvest rainwater via cisterns for both potable and non-potable reuse, pavements are generally designed exclusively for vehicles and pedestrian walkways with little consideration of hydrologic impacts. Concrete, asphalt, or compacted gravel generates excessive runoff and pollutant loads, opportunities to be more efficient with hardscapes that meet vehicular needs, pedestrian access, water supply, and stormwater management objectives. This can be done with a series of common-sense approaches to parking lot, street, driveway, and roof design that maintain function and safety while reducing that amount of runoff that must be managed by other practices.

When designing a new parking lot or building, or if retrofitting an existing site, consider one of the following strategies for incorporating LID:

1. Reduce impervious cover and the resulting runoff through design techniques that lead to smaller parking and building footprints, more green space, and skinnier streets, while maintaining adequate and safe facilities. This happens early in the design stage and may require working with agencies to provide flexibility in design standards.

2. Replace standard impervious pavements such as asphalt or concrete with permeable surfaces (e.g., pavers, porous asphalt/concrete). This is particularly good for overflow parking, parking stalls, parking lanes, driveways, and patios/hardscapes.
3. Permeable paver applications seem to be more commonly used in the VI than porous asphalt or concrete, likely due to limitations of island-based processing plants.
4. Couple vegetated SCMs within parking lots, roadway sections, and patios, to manage and treat runoff at the source. Consider vegetative options for rooftops that can also provide energy savings and active use benefits.
5. Use cisterns and storage chambers above or below hardscapes for reducing runoff volumes and rainwater harvesting for potable and non-potable use without sacrificing additional space on site.

### Runoff Disconnection and Distribution

Disconnect impervious cover by allowing small runoff volumes to sheet flow into existing pervious areas where it can soak into ground, be taken up by plants, or evaporate (note: this does not mean discharge to your neighbor's yard or an adjacent waterway). Qualified pervious areas must have 3-4 inches of soil or organics that can absorb runoff and be outside of regulated resources such as wetlands or gut buffers. Distributing smaller practices around the site offers more opportunities to capture runoff closer to the source and provides leeway if one part of the system fails. A large detention pond at the bottom of the site may be your only option for managing large storms and preventing flooding; however, this approach generally reduces the site's overall stormwater resiliency and ability to meet runoff reduction and water quality treatment targets (see **Chapter 5** storage practices). Reliance on a single storage practice, while perhaps more efficient to maintain, puts all management eggs into one basket. Large facilities generally take up valuable space and require more pipes and costly materials. Tips for disconnection and distribution include the following:

1. Break the up impervious elements of a site into smaller drainage areas. Determine what can be drained to pervious areas without concentrating or causing erosion. Where the volumes are too large, manage each area with smaller SCMs.



*Swap out hot pavement for cooler grass in areas where pedestrians walk. Smaller areas of impervious can drain to pervious areas for runoff reduction.*



*This housing development on St. John used permeable driveways to reduce the amount of runoff volume to be managed downhill.*



*Cisterns and tanks are commonly used in the VI for rainwater harvesting.*

2. Connect SCMs in a treatment train approach, where one vegetated surface practice can overflow into an infiltration, rainwater harvesting, or storage practice.

### 3.3 PLANNING FOR ROADS AND DRIVEWAYS

The most important factor affecting the longevity of any unpaved road is drainage. The size of the contributing drainage area, slope and length of road, and surface erodibility are key factors influencing how water impacts road conditions. Too much surface water can weaken a roadbed resulting in rutting, potholes, shoulder erosion, ditch washouts, and clogged culverts. Water flowing too slowly can deposit sediments and clog channels and culverts. Standing water can weaken the sub-base, lead to surface failure, and promote road widening as drivers attempt to avoid puddles. **Chapter 4** provides details on the specific drainage practices to use on unpaved roads. This section provides guidance adapted from the Unpaved Road Standards for Caribbean and Pacific Islands (Kitchell et al., 2021) on the overall design and layout of unpaved roads. These guidelines should be followed for temporary construction access roads, driveways, and existing unpaved roads. New, permanent unpaved roads are no longer allowed without a waiver in the VI and there are expectations that newly constructed roads will be paved within a short period of time (paving does not exclude permeable options)!

#### Road Planning Principles

Six key principles of good unpaved roads are:

1. Get water off the road quickly to prevent concentrating or ponding on the surface.
2. It is better to disperse water than to collect it.
3. Maintain proper road cross slope and surface compaction.
4. Stabilize all conveyance ditches, outfalls, and slopes.
5. Disconnect from paved surfaces.
6. Commit to routine, long-term maintenance to minimize frequency of grading and major repairs.

**Figure 3.9** illustrates the basic features of an unpaved road. Road slope, position, composition, and cross slope are key factors influencing erosion. The steepness of a road factors into the magnitude of erosive forces created by runoff because, as road slope increases, runoff concentrates more quickly and can attain higher velocities (**Table 3.4**). Ideally, unpaved roads will have a 10% or flatter grade, but it is not



The last place you want concentrated flows is in the travel lane since this will lead to erosion.

uncommon to see island roads with 30% or greater slope. **Figure 3.10** provides handy conversion information for calculating and comparing degrees, percent slope, and H:V ratios to describe slope steepness.

The position of a road on a hill and the size of the contributing drainage area can influence the amount of runoff volume coming to each road segment. Road segments located at the bottom of a hill with a large drainage area will receive more runoff than a segment of road at the top of the hill.

The road cross-slope or pitch will dictate which drainage structures are used, such as ditches, cross drains, etc. **Table 3.5** shows outsloped, insloped, and crowned road profiles. Many roads will have segments of varying pitch, but generally, a 3-6% pitch is desired. Outsloped roads are great for distributing sheet flow off road. Changes in road shape without adjustments to drainage controls can result in road failure. Expect the original road shape to be lost overtime.

*Table 3.4. Steep Road Conditions*

Gradient	% Slope	Anticipated Condition
Low	<5%	Do not typically have erosive runoff velocities under normal conditions.
Medium	5-10%	Have potential for erosion and sediment transport, if left unmanaged. Good drainage design is critical.
High	10-20%	Likely to have severe erosion problems and require frequent maintenance; should be aggregate surface
Severe	20-30%	Hard to maintain at this severe slope; should be paved.

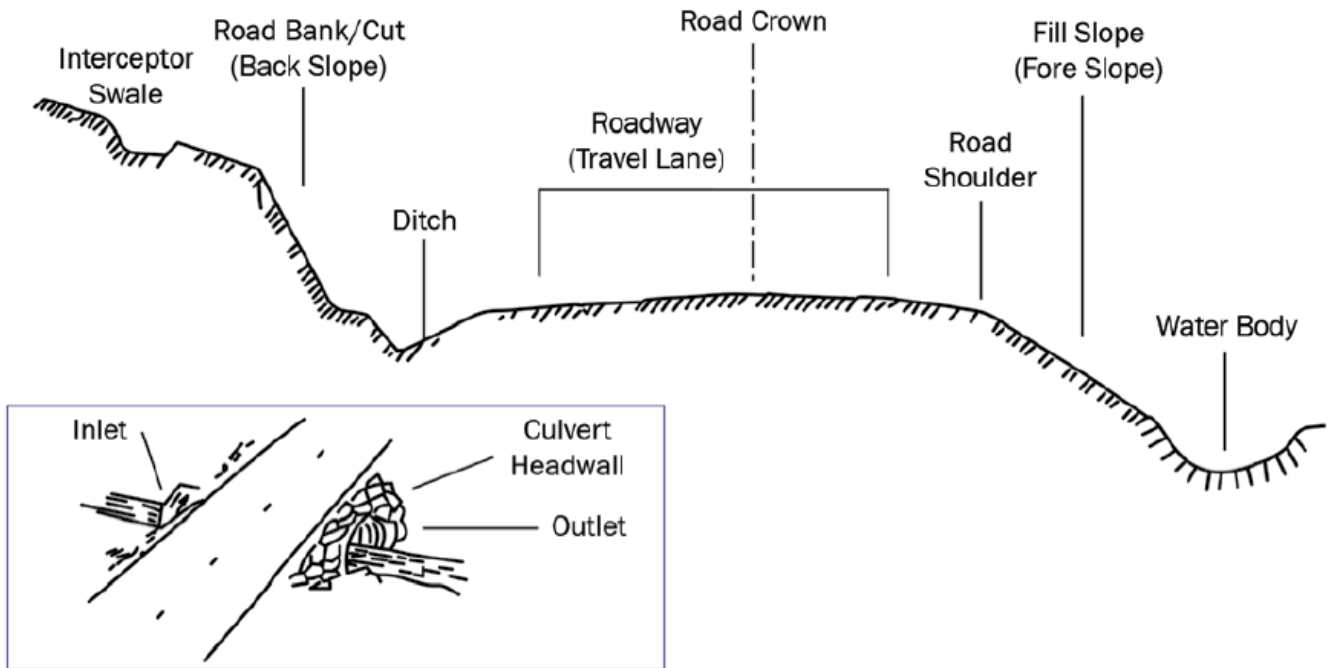

Figure 3.9. Road elements (Adapted from VT Better Backroads Erosion Inventory Assessment Manual, 2015)

Table 3.5. Road Shape/Pitch (graphics from Environmentally Sensitive Maintenance Practices for Dirt and Gravel Roads, 2012)

Road Pitch	Cross-section	Features
<b>Insploped</b>		<ul style="list-style-type: none"> <li>• High point on the downhill side of road</li> <li>• Drains to inside ditch, may have frequent cross culverts</li> <li>• Concentrates runoff against the backslope</li> <li>• Used for steep side slopes to ensure safety or where outsloping could cause erosion or instability</li> <li>• Directs flow away from fill slope</li> </ul>
<b>Outsloped</b>		<ul style="list-style-type: none"> <li>• High point on the uphill side of road</li> <li>• Eliminates ditches and need for cross-culverts, best for dispersed flows</li> <li>• Drains to downhill side</li> <li>• Typically used on road slopes less than 8%</li> <li>• Avoid where unsafe drop off exists below roadway</li> </ul>
<b>Crowned</b>		<ul style="list-style-type: none"> <li>• Shape road with a high point in the centerline and continues fall towards both shoulders-generally at least 1/2 to 3/4 inch of fall per foot across road (4-6%).</li> <li>• Fastest water removal - drains in either direction</li> <li>• May require water management on both sides of road</li> <li>• Most common on double lane roads</li> <li>• Effective for road slopes <math>\geq 8\%</math></li> <li>• Avoid on single lane roads prone to rutting</li> </ul>

DEGREES (x°)	PERCENT (%)	RATIO (H:V)
2.5	5.0	
5.7	10.0	10:1
10.0	17.6	
14.0	25.0	4:1
18.0	33.5	3:1
19.3	35.0	
20.0	36.4	
24.2	45.0	
26.1	49.0	
26.6	50.0	2:1
30.0	57.7	
33.0	66.7	1.5:1
35.0	70.0	
38.6	80.0	
42.0	90.0	
45.0	100.0	1:1
55.0	142.8	
60.0	173.2	

### Slope Determination Formulas

Slope Ratio: HD:VD

Slope Percent:  $\left(\frac{VD}{HD}\right) \times 100$

Slope Angle:  $\text{Arctan}\left(\frac{VD}{HD}\right)$   
(degrees)

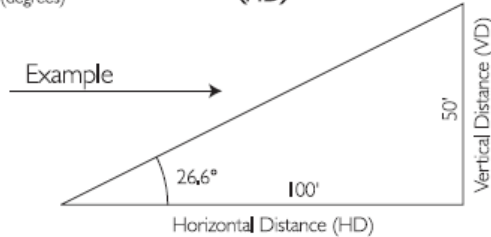

### Examples

Slope Ratio: 100:50 = 2:1

Slope Percent:  $\left(\frac{50}{100}\right) \times 100 = 50\%$

Slope Angle:  $\text{Arctan}\left(\frac{50}{100}\right) = 26.6^\circ$   
(degrees)

Figure 3.10. The Relationship between Degrees, Percent Slope, and Ratio (from Washington Coastal Training Program and Greenbelt Consulting, 2004)

The surface material and gradation (particle size) of unpaved roads is also an erosion factor. Ideally, a road surface will contain a mixture of both fine and coarse aggregate compacted over a base course (**Figure 3.11**). These surfaces can last 3-5 years without reshaping. Many unpaved roads, however, are constructed simply by grading the native surface material exposed during clearing rather than bringing in aggregate from off-site. Because these “dirt” roads do not have an adequate gradation of material, they are unable to be properly compacted and are highly prone to erosion. They also may erode down to bedrock, making drainage adjustments nearly impossible. These roads will require frequent resurfacing.

Loss of road shape, lack of drainage controls, and inadequate maintenance are big contributors to erosion issues. Erosion patterns can serve as visual clues for diagnosing drainage problems and identifying solutions (**Table 3.6**).



Native soil (top), when loose and unconsolidated is highly prone to erosion. High clay content can make it slippery when wet. Bedrock below a thin layer of sediment (bottom) makes creation of ditches and installation of cross-drains a challenge.



## ROAD SURFACE MATERIAL

THE SURFACE OF UNPAVED ROADS IS COMPOSED OF A MIXTURE OF COURSE AGGREGATES AND FINE MATERIAL (FINES).

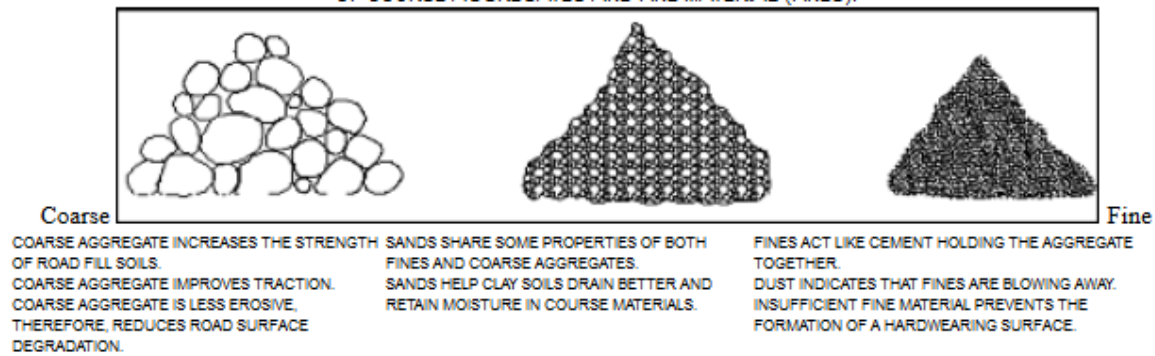

Figure 3.11. Mixed components of road surface mixture (Recommended Practices Manual, A Guideline for Maintenance and Service of Unpaved Roads, 2000)

### Designing for Drainage

When planning for a new, unpaved road or driveway, it is good practice to:

1. Delineate the contributing drainage area and look to eliminate off site sources, including other roads or driveway tie-ins.
2. Identify downstream flow paths, low points, and existing environmental resources or infrastructure that may receive runoff.
3. Determine shape/pitch, anticipated usage/traffic load, safety issues, and road surface material type (aggregate or dirt).
4. Consider paving in high use areas and on very steep slopes to minimize sediment transport.
5. Minimize the overall footprint– keep road widths to a minimum needed to convey expected road usage.
6. Shape roads to shed water and prevent accumulation and concentration of flows on the road surface. Plan for interception, collection, and dispersal of surface drainage.
7. Identify staging areas to minimize unnecessary disturbance during construction and maintenance.
8. Provide a plan for temporary erosion and sediment control during construction.
9. Provide a simple O&M plan for future maintenance (e.g., identify key grades, outlet locations, and spots where sediment removal is required).



1"-3" stones used as a base course. This stone is also good in ditches and as chocker stone in riprap applications.



Smaller angular, 3/4" gravel serves as a good void filling component for compacted surface courses and for backfilling check dams.



Example of well-graded gravel surface that incorporates fines for better compaction; holds up better to traffic than loose gravel.

Table 3.6. Common Types of Erosion Observed on Unpaved Roads (adapted from Kitchell et al., 2021)

		
<p><b>Rill:</b> small, shallow, braided channels that do not cut much below the upper surface (a few inches only). <b>Raveling:</b> loss of course aggregate. Correct by grading or blading to improve surface composition. <b>Dust:</b> loss of fines- correct with better compaction and stabilizer.</p>	<p><b>Rutting/gullying:</b> active down-cutting that creates deep, longitudinal depressions in the wheel paths caused by high moisture content, inadequate course thickness/strength, lack of drainage controls, or heavy traffic. Needs stronger base course or geosynthetics.</p>	<p><b>Potholes:</b> "holes" in surface caused by excessive moisture, poor drainage, and poorly-graded aggregates. Correct with spot grading or patching with crushed aggregate. Stronger base layer and geotextiles can help.</p>
		
<p><b>Washboards:</b> series of ridges or depressions across surface caused by lack of surface cohesion and excessive vehicle speeds. Correct by remixing surface, scarify while damp, re-grade, and compact.</p>	<p><b>Slumping or sloughing:</b> where water under cuts the soil or saturates a steep bank leading to a collapse. Could occur on outside edge of fill or cut slopes or around headwalls or other infrastructure abutments.</p>	<p><b>Scour:</b> erosion in ditches, at outfalls, or culverts where velocity of runoff has cut into bank or bed surface.</p>
		
<p><b>Depressions and soft spots:</b> localized ponding areas or muddy sections of road caused by lack of drainage, settling, and exacerbated by traffic. Correct by regrading, filling with aggregate or surface material, or adding geosynthetics, dip, or turnout, etc.</p>	<p><b>Entrenchment:</b> road surface elevation is cut well below both road banks, giving runoff no place to get off the road. Could be caused by overgrading or buildup of the outslope edge. Correct by raising surface elevation.</p>	<p><b>False ditch:</b> eroded gully on the outer edge of travel lane caused when ditch becomes disconnected from surface flow due to build up of material in the shoulder (e.g., windrow, vegetation, grader berm). Correct by removing buildup that is blocking positive drainage, filling, and compacting false ditch; ensure proper pitch on road.</p>

## Drainage Control Practices

To manage surface drainage, there are various structural controls that can be used depending on the situation (see **Chapter 4**). To meet Stormwater Standards for Unpaved Roads (UR1-10):

- Select drainage practices based on material availability, constructability, maintenance burden, and site constraints. For example, if bedrock is at the surface, then digging ditches or pipes below grade may be challenging.
- Specify road bedding and surface aggregate and compaction standards in contracts (UR-8). Pave or use surface aggregate when necessary (>10% slope use aggregate, >20% slope pave) (see UR-5).
- Delineate the contributing drainage area to the road and identify opportunities to reduce run-on from outside the road and its immediate right-of-way (UR-2).
- Consider how to stabilize slopes before cutting a road (UR-9). Choose road layouts that will minimize the drainage burden (UR-3, 4, & 5). Remember that subtle changes in road grades can help to prevent scouring and sediment transport and reduce the number of turnouts or other practices needed.
- Don't be thrifty with the number and size of drainage practices. Provide more cross-drains, dips, check dams, and turn outs than needed to provide redundancy in case something gets clogged. Go big with your pipes, ditches, and traps assuming higher volumes (UR 6, 7 & 9).

## More on Ditches

In sloped profiles often require ditches to convey concentrated and potentially erosive flows to a designated outlet. Many ditches are downcut and degraded because they carry too much water and are too steep, which increases the erosive power of runoff. Ditch maintenance generally just addresses the symptom (erosion) rather than the problem (velocity and volume). Road designs that minimize or eliminate ditches or increase the number of outlets are desirable to reduce long-term maintenance costs and to improve downstream water quality.

Factors affecting ditch stability include:

- Volume of runoff—length of ditch run; size of contributing drainage area; subsurface springs and seeps; portion of runoff getting into ditch
- Road geometry—slope, pitch, grade breaks, and number of curves
- Soil type and texture
- Number of ditch outlets

Observing what is happening (and where) in a roadside ditch can help inform decisions about how to modify drainage designs or plan for new roads. Suggestions for evaluating an existing ditch are as follows:

1. Start walking the ditch at the top of the hill. This allows you to identify problems as soon as they become visible.
2. Follow ditch downhill, locating number of outlets. Note location and frequency of outlets and where you see erosion occurring.
3. Look for signs of debris or scour from big events (hurricanes).
4. Look for opportunities to create a new drainage outlet ABOVE erosion points.
5. Estimate how long ditch can remain stable. The distance from top of hill to first point of erosion gives a good estimate, unless there are significant changes in slope or additional drainage contributions. Use this strategy to estimate spacing for turnouts as you walk downhill.
6. Make note of additional water sources on the way down. Look for ways to disconnect this run-on to minimize additional volumes.
7. Try to outlet ditches before curves or extremely steep road sections.
8. Look for ways to outlet and provide sediment pretreatment prior to discharge to streams/wetlands. Consider use of traps or sediment forebay.
9. Evaluate existing outlet condition. If they are eroded or plugged/clogged, it might be good idea to install a new one just uphill to help disperse drainage.

## Construction Planning

Construction rarely goes exactly as planned, especially if existing conditions were not fully documented. The steps for managing stormwater when building a road are not dissimilar from standard construction sites:

- Hold a preconstruction meeting with owners, contractor, and agency.
- Protect large trees or other sensitive vegetation with visible markers, changes in road layout, or plant relocation. The canopy is your friend and roots keep soil stable.
- Minimize clearing and grading footprint. Clear by hand in sensitive areas or use a phased approach. Cut vegetation 3 ft or higher, leaving stalks and roots to hold soil in place until grading is imminent.
- Phase road construction as needed to ensure immediate installation of drainage controls and staging areas needed for each segment. Monitor the weather and “don’t bite off more than you can chew” in a day.
- Remove and stockpile topsoil for reuse.
- Balance cut and fill volumes; avoid sidesteading of cut material except where fill is needed. Immediately track and stabilize loose sidecast to prevent mobilization during storms (**Figure 3.12**).
- Use proper erosion and sediment control measures to prevent erosion. Stabilize cut and fill slopes immediately.
- Do not cut corners with size and material of surface aggregate.
- Compaction, compaction, compaction.
- Provide an as-built survey or drawing showing actual road elevations and structure locations that differ from the approved plan.
- Never walk away from an unpaved road job that lacks proper drainage controls.

### A Commitment to Maintenance

Unpaved roads will require continuous inspection and maintenance for the duration of their use. When planning for unpaved roads, consider the following:

1. Annual maintenance will require funding and the designation of a responsible road manager. Road segments that will require the most maintenance will be those that are steep, have large drainage areas, lack proper drainage structures, consist of un-compacted dirt, and are highly traveled. While an aggressive drainage plan may improve the longevity of the road surface, these practices will all require regular maintenance.

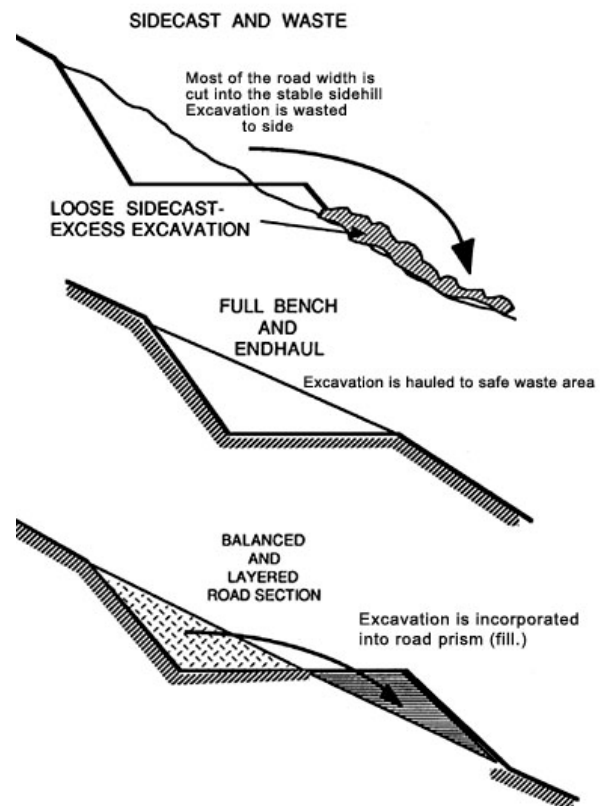

Figure 3.12. Road Construction Options (from FAO Watershed Management Field Manual)

2. Have a maintenance plan with accompanying map that shows the designed road geometry and locations of drainage infrastructure.
3. Use proper equipment for blading, shaping, mixing, and compacting during surface maintenance, as well as for shoulder cutting and ditch cleaning operations (See FHA, 2015).
4. Maintain proper road shape and drainage during grading, which may require raising road elevation by bringing in material.
5. Commit to a routine inspection frequency for roads to prevent unnecessary surface damage resulting from blocked or clogged drainage structures. Inspections should include an evaluation at discharge locations in downhill guts and public roadways.
6. A good maintenance regime should strive to address the causes of erosion, not just clean up the symptoms. When inspecting roads, look for visual clues to identify maintenance needs, diagnose causes, and identify solutions (**Table 3.7**). Start at the top of the road and walk downhill during inspections.

Table 3.7. Common Unpaved Road Erosion Symptoms and Solutions (from Kitchell et al., 2021)

Indicator	Possible Causes	Potential Solutions
<b>Surface rills and rutting, ponding on road</b>	<b>Loss of road shape.</b> Has the pitch changed? Can water get off road?	Re-grade to original shape or establish a preferred cross-slope for better drainage. May need to bring in material to raise road profile.
	<b>Inadequate or inconsistent drainage design.</b> Were enough drainage structures provided, if so, why are they not functioning?	Add more drainage structures to get water off the road surface. Walk road starting at the top to identify locations where surface erosion starts. Look for ways to intercept or disperse flows above this location. May need to raise areas of ponding and divert flows.
	<b>Increase in traffic or runoff volume.</b> Is there a heavier traffic load? Has the contributing drainage area expanded?	Look for ways to disconnect flow before it gets to road. Heavier traffic load may require better compaction, more waterbars to slow traffic, or resurfacing with better aggregate course or paving.
	<b>Lack of maintenance.</b> Are drainage features blocked or clogged causing backup on surface? Has the road been regraded in the last 5 years?	Dirt or inadequately compacted road surfaces will release more sediment that will quickly fill in culverts, cross-drains, etc. Use shovels or equipment to remove blockages and accumulated sediment. Removed material can be mixed back into surfacing and compacted. Do not discard down the hill or in stream.
<b>False ditch</b>	Water cannot get into ditch because of vegetation, berm, or other change in shoulder elevation.	Remove buildup material and re-establish positive drainage from road surface. Clean out and reshape the ditch. Stabilize ditch with vegetation or stone.
<b>Sediment buildup in waterbars, pipes, ditches, etc.</b>	<b>Excessive erosion of road surface or ditch scour.</b> Where is sediment coming from?	Sedimentation is a symptom of a bigger problem. Identify and address source of sediment (see surface rills and rutting and ditch erosion solutions) to retain capacity.
	<b>Lack of maintenance.</b> When was the last time these were shoveled out? Is there a blockage?	Use shovels or equipment to remove blockages and accumulated sediment. Removed material can be mixed back into the road surfacing and compacted. Do not discard down the hill or in stream.
	<b>Standing or slow-moving water.</b> Is there a blockage creating backups?	Remove any blockages that may be backing water up or causing flows to slow down enough to drop sediment out.
	<b>Incorrect waterbar, etc. alignment.</b> Is angle sufficient?	Reinstall water bars and cross-drains that do not have a 30-degree angle to travel lane to promote self-cleaning.
<b>Scour around culverts, cross-drains, or below outfalls</b>	<b>Blockage.</b> Is the pipe clogged, collapsed, or blocked by debris?	Use shovels or equipment to remove blockages and accumulated sediment.
	<b>Culvert undersized.</b> Is the pipe too small to handle volume?	Divert flows upstream or replace with larger pipe. Add headers or wingwalls at inlet.
	<b>Excessive water volume.</b> Has the contributing area expanded?	Look for ways to disconnect flow before it gets to road. Add headers or wingwalls at inlet.
	<b>Lack of stable outlet.</b> Do you see scour due to lack of stone?	Add stone or other outlet protection devices. Stabilize slope with vegetation or other.
<b>Ditch erosion or overflow</b>	<b>Excessive water volume.</b> Are ditches sized for 10-yr storm?	Divert any contributing off-site run-on. Stabilize slopes and maintain roadside vegetation.
	<b>Lack of turnouts.</b> Does the ditch need relief?	Walk ditch, starting at top. Look for opportunities above problem areas to add more turnouts or cross drains.
	<b>Excessive velocity.</b> Is there anything slowing flows or protecting slopes?	Add check dams. Stabilize slopes and maintain roadside vegetation. Add more turnouts or cross drains.
	<b>Overgrown, filled in, blockages.</b> Are overflows happening due to backup or loss of capacity?	Need to restore capacity behind check dams. Unclog culverts or turnouts and remove debris. You may need to raise the road profile to re-establish ditches.

### 3.4 GOOD HOUSEKEEPING PRACTICES

Good housekeeping refers to keeping a clean and orderly construction site. Good housekeeping practices and common sense prevent contamination of stormwater runoff from construction site chemicals. Good housekeeping practices can reduce accidental spills, improve spill response times, and reduce safety hazards. These practices are inexpensive, relatively easy to implement, and are often effective in preventing stormwater contamination. They can also reduce costs by preventing unnecessary loss of products.

The 2002 Handbook identified three areas related to good housekeeping on a construction site that should be addressed: proper disposal of building material wastes; proper storage and handling of chemicals used on the construction site; and implementation of a spill prevention and control plan.

#### Waste Disposal

Proper management and disposal of building materials and other construction site wastes is an important part of pollution prevention. Sources of pollution include surplus or refuse building materials as well as hazardous wastes. All controls and practices must meet the requirements of your Earth Change or CZM Permit and other Federal and Territorial requirements your site is subject to. Contact the Department of Public Works (DPW) to find out more about waste disposal regulations, or the Department of Planning and Natural Resources (DPNR) to find out how to safely handle, store and dispose of hazardous and toxic chemicals. Construction projects tend to generate large amounts of solid waste materials that are unique to this activity. These wastes may include, but are not limited to:

- Trees and shrubs removed during clearing and other phases of construction;
- Packaging materials (wood, paper, plastic, cardboard, etc.);
- Scrap or surplus building materials (scrap metals, rubber, plastic and glass pieces, masonry products, etc.);
- Paints and paint thinners; and
- Materials generated by structure demolition.



*Inspirational signage to remind us that good housekeeping practices can help prevent pollution.*

Steps to be taken to properly dispose of construction wastes include:

1. Select a designated waste collection area onsite;
2. Provide an adequate number of containers with covers;
3. Locate containers in a covered area, when possible;
4. Arrange for waste collection before containers overflow;
5. Provide immediate clean-up in the event of a spill;
6. Plan for additional containers and more frequent pick-ups during demolition phases;
7. Make sure that construction waste is collected, removed and disposed of only at authorized disposal areas; and
8. Check with DPW or DPNR for specific guidance.

Many materials found at construction sites may be hazardous either to personnel or to the environment. Always read the labels of the materials and products present onsite—they may contain warning information that will help you be aware of potential problems. Hazardous products at construction sites include, but are not limited to:

- Paints;
- Acids for cleaning masonry surfaces;
- Cleaning solvents;
- Chemical additives used for soil stabilization;
- Concrete curing compounds and additives; and
- Pesticides, herbicides, fungicides, and rodenticides.

Most problems involving hazardous materials result from carelessness or from not using common sense. The practices listed below will help avoid problems associated with hazardous material disposal. Section 2.6.2 contains further information on hazardous material handling and storage and section 2.6.3 discusses spill prevention plans.

1. Check with DPNR to determine the requirements for hazardous material disposal.
2. Use all of the product before properly disposing of the container – if you must dispose of surplus products, do not mix products together unless specifically recommended by the manufacturer.
3. Do not remove the original product label from the container, it contains important information.
4. Follow the manufacturer's recommended method of disposal for the product and the empty container (often found on the label).

## Material Management

Material management is the best way to avoid a problem. On a construction site, the material storage area can become a major source of pollution due to the mishandling of materials or accidental spills. An inventory of the material storage area and of the site should be made. Special care should be taken to identify any materials that have the potential to come into contact with stormwater. There are a number of risks (other than stormwater contamination) to consider in the management of materials on a construction site, including health and safety of employees and groundwater contamination. However, this section only addresses stormwater contamination risks. Contact DPNR for information about measures to minimize other risks. Materials to be considered when evaluating potential risks include, but may not be limited to:

- Pesticides;
- Petroleum products;
- Fertilizers and detergents (nutrient sources);

- Construction chemicals;
- Other pollutants; and
- Hazardous products (see previous section).

Information to be evaluated for onsite risk assessment:

- What types of materials are stored onsite?
- How long will the materials be stored before they are used?
- Are you storing more than is needed?
- How are the materials stored and distributed?
- How can potential contact with stormwater be avoided?

Pesticides include insecticides, rodenticides, and herbicides are commonly used on construction sites. These chemicals should be handled as infrequently as possible. All applicable Federal and Territorial regulations when using, handling or disposing of these materials must be observed. Management practices that can reduce the amount of pesticides coming into contact with stormwater include the following:

1. Store pesticides in a dry, covered area that is away from drainage flow paths;
2. Provide curbs, dikes or berms to contain potential pesticide spills;
3. Have measures on site to contain and clean up pesticide spills; and
4. Strictly follow recommended application rates and methods.

Petroleum products include oil, gasoline, lubricants, and asphaltic substances such as paving materials. These materials should be carefully handled to minimize their exposure to stormwater. Petroleum products usually occur in two areas: 1) where road construction is occurring; and 2) in vehicle storage, fueling, or equipment maintenance areas. Practices that can be used to reduce the risks of using petroleum products:

1. Provide equipment to contain and clean up petroleum spills in fuel storage areas or on maintenance and fueling vehicles;
2. Store petroleum products and fuel vehicles in covered areas;
3. Contain and clean up petroleum spills immediately;
4. Perform preventative maintenance of equipment

- used onsite to prevent leakage (e.g., check for and fix gas or oil leaks in construction vehicles on a regular basis); and
5. Properly apply asphaltic substances (see manufacturer's instructions) to reduce spill risks;
  6. Build impervious dikes or berms to contain any spills; and
  7. Install oil/grease separators in stormwater inlets (see **Chapter 5**).

The proper landscaping or revegetation of construction sites often requires using fertilizers and detergents that contain nutrients such as nitrogen and phosphorus. Excess quantities of these nutrients can be washed away by stormwater runoff and become a major pollution problem. Excess nutrients in wetlands and coastal waters can cause eutrophication and other pollution problems. Practices that can be used to reduce the risks of nutrient pollution include:

1. Only apply fertilizers when absolutely necessary to revegetate disturbed areas;
2. Apply fertilizers to a minimum area and at the minimum recommended amount and rate (time-released fertilizers can be used);
3. Work fertilizers into the soil to reduce exposure of nutrients to stormwater runoff;
4. Seed and fertilize in one application (see section on Hydroseeding in Chapter 3); and
5. Implement good erosion and sediment control practices to help reduce the amount of sediment and fertilizers that leave the site (see Chapter 3).

### Spill Prevention and Response

Spills of pesticides, petroleum products, or other toxic or hazardous products can contaminate soil, water and waste materials resulting in potential health risks. Preparations should be made to deal quickly and effectively with accidental spills. A spill control plan can help you be prepared. This section discusses your additional responsibilities if there is a reportable quantity spill. A spill control plan should include methods to:

1. Stop the source of the spill;
2. Contain the spill (i.e., utilizing impervious liners and collection containment systems);
3. Clean up the spill (i.e., filtration systems);
4. Dispose of all materials contaminated by the spill;

5. Contact qualified personnel responsible for spill prevention and control.
6. Store and handle materials to prevent spills.
  - Tightly seal containers.
  - Make sure all containers are clearly labeled.
  - Stack containers neatly and securely.
7. Reduce stormwater contact if there is a spill.
  - Have cleanup procedures clearly posted.
  - Have cleanup materials readily available.
  - Contain any liquid.
  - Stop the source of the spill.
  - Cover the spill with absorbent material such as kitty litter or sawdust.
8. Discard contaminated materials according to manufacturer's instructions or according to Federal or Territorial requirements.
9. Identify personnel responsible for responding to a spill of toxic or hazardous materials.
  - Provide personnel spill response training.
  - Post names of spill response personnel.
10. Keep the spill area well ventilated.
11. If necessary, use a private firm that specializes in spill cleanup.

## 3.5. OPERATIONS AND MAINTENANCE

A successful stormwater system requires attention to ongoing operation and maintenance. Failure to provide effective maintenance can reduce the functional capacity and pollutant removal efficiency of the practice as designed and lead to unintended downstream consequences.

Many people expect that stormwater facilities will continue to function correctly as designed forever, but structural repairs, landscape maintenance, and sediment removal will be necessary over time. The question is not whether maintenance is necessary but rather, how often? Instead of reacting to flooding, erosion, clogging, or outright failure, operation and maintenance should be proactive.

The information provided here is primarily for achieving Stormwater Standard SW-7 but can also be applied to O&M planning for ESC-10 and UR-10.



To adequately maintaining a stormwater management infrastructure, you must:

1. Develop an Operations and Maintenance Plan;
2. Understand the functional elements of your stormwater system;
3. Conduct periodic and scheduled inspections, and
4. Perform scheduled and corrective maintenance.

## Operations and Maintenance Plans

Most development permits require submittal of a formal stormwater operations and management plan (O&M plan). A copy of this plan should be kept on site, with inspection and maintenance logs. All O&M plans should include the following elements:

- Contact information for the owner, operator/facilities manager, and installer or manufacturer, if available.
- Average annual maintenance budget broken out by stormwater infrastructure component.
- Site map and design plan showing the location and design elements of the structural stormwater system; a landscape plan and site map showing mow/no mow or bushwack/no bushwack parts of the site; and an invasive plant or “weed” guide.
- Narrative description of each structural and planting system component and recommended maintenance procedures. For a listing of specific maintenance requirements for individual stormwater control measures, designers should refer to the applicable sections in **Chapter 5**. In some cases, inclusion of the manufacturer’s maintenance requirements can be helpful.
- Landscape maintenance for stormwater practices should include guidance on cutting and pruning, mowing, weeding, watering, seeding, and plant replacement.
- General site inspection procedures to identify pollution prevention measures (e.g., trash and debris, spill prevention and control measures, pavement sweeping, pet waste)
- Inspection procedures, frequencies, and checklist. A sample checklist is provided in **Appendix C** that can be used during maintenance inspections.
- A signed maintenance agreement (see **Appendix C** for an example).

## Functional System Components

Most stormwater infrastructure relies on five basic steps to function properly. There are specific structural components of SCM design that facilitate each step. If one of these steps or components does not work properly, the entire system can be compromised and the stormwater practice itself could be contributing to maintenance problems. This can lead to landscape nuisances, more frequent maintenance and costly repairs/improvement. The O&M plan should clearly identify the functional components of each practice. Steps and the respective components include:

1. Collect runoff at inlets (e.g., catch basins and paved flumes).
2. Carry water to or through the facility through conveyance structures, such as swales.
3. Capture sediment with pretreatment devices, such as forebays and sumps.
4. Treat and manage runoff through filtering media, plant uptake and evapotranspiration, infiltration mechanisms, or storage devices.
5. Overflow excess runoff through protected outlet structures and spillways.

O&M site maps should show where each of the functional components are, what to look for during inspection, and what steps to take if an action is required (**Figure 3.13**)

**Isolator Row Plus Step By Step Maintenance Procedures**

**Step 1**  
Inspect Isolator Row Plus for sediment.  
A) Inspection ports (if present)  
i. Remove lid from floor box frame  
ii. Remove cap from inspection rise  
iii. Using a flashlight and steady rod measure depth of sediment and record results on maintenance log.  
iv. If sediment is at or above 3 inch depth, proceed to Step 2. If not, proceed to Step 3.  
B) All Isolator Row Plus  
i. Remove cover from manhole at upstream end of Isolator Row Plus  
ii. Using a flashlight, inspect down Isolator Row Plus through outlet pipe  
1. Mirrors on poles or cameras may be used to avoid a confined space entry if enter  
2. Follow OSHA regulations for confined space entry if enter  
iii. If sediment is at or above the lower row of sidewall holes (a)  
2. If not, proceed to Step 3.

**Step 2**  
Clean out Isolator Row Plus using the JetVac process.  
A) A fixed floor cleaning nozzle with rear facing nozzle spread of 4  
B) Apply multiple passes of JetVac until backflush water is clean  
C) Vacuum manhole sump as required

**Step 3**  
Replace all caps, lids and covers, record observations and actions.

**Step 4**  
Inspect & clean catch basins and manholes upstream of the Storm!

**Sample Maintenance Log**

Date	Inspected by	Fixed ports (sediment) (1)-(2)	Fixed ports (sediment) (1)-(2)	Observations/Actions	Int.
8/15/11	A-B-R	none	none	New installation, fixed port to CE frame at grade	373
9/16/11	A-B-R	0.5 ft	0.5 ft	Some grit fall	56
4/29/12	A-B-R	0.5 ft	0.5 ft	Heavy dust, debris visible in manhole and in Isolator Row PLUS, maintenance due	167
7/7/13	A-B-R	0	0	Bottom left lid not re-secured	373

**Isolator® Row Plus O&M Manual**

ADS StormTech

Example manufactures maintenance guide that can be inserted into your O&M plan.

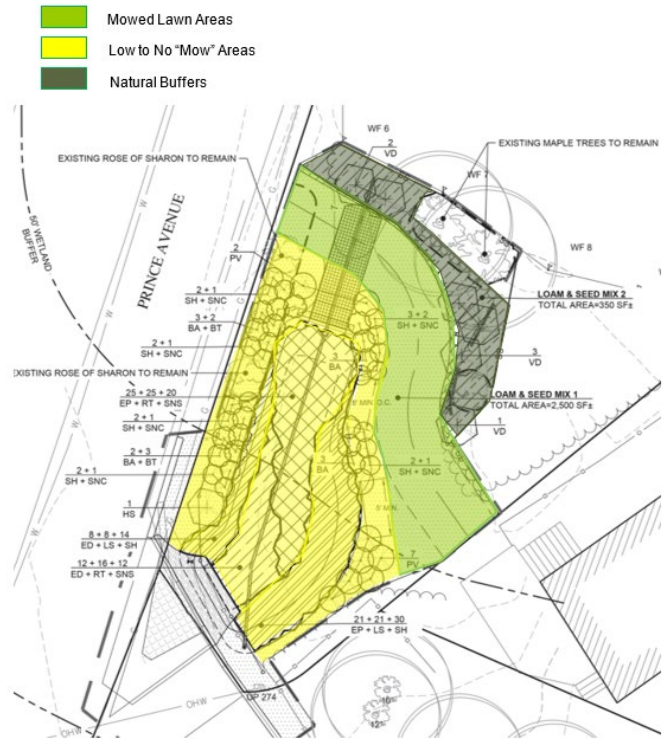
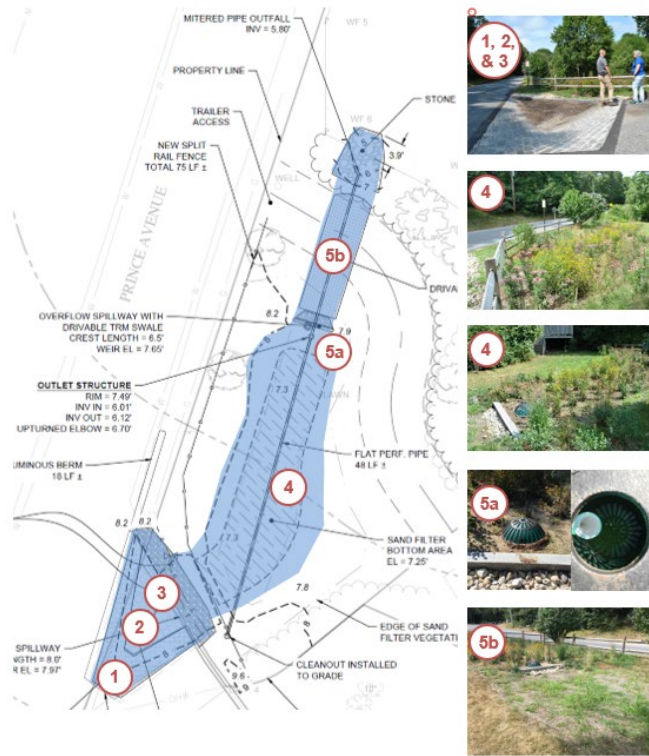

Maintenance Item	Description
<b>1, 2 &amp; 3. Catch Basins, Inlet Flumes, Sediment Forebays, and Check Dam Weirs</b>	
Debris Cleanout	Remove all trash, leaf litter and debris from the catch basins, inlet flumes, and forebays.
Sediment/Organic Debris Removal	Check for clogging and sediment accumulation that impacts inflow and outflow. Remove and properly dispose of when sediment is >3" in forebays. Remove/cut any vegetation that sprouts through voids in stone, pavement, or pavers.
Erosion	Check for areas of erosion (gullies, animal burrowing, or overtopping), particularly near check dam weirs, perimeter, and guard rail posts. Repair as necessary and return to design grades.

**Actions to be taken:**

### 3.4 Structural Components

- Collect:** Stormwater is captured in a slight depression (inlet) made of drivable pavers along the edge of the parking lot.
- Capture Sediment:** Sand and debris settle out within the permeable paver sediment forebay.
- Move Water:** Stormwater exits the forebay flowing over a weir structure and stone splash pad to the sand filter area.
- Treat and Manage:** Sand filter area media and vegetation remove nitrogen and bacteria and allow treated stormwater to infiltrate into the soil below; when the groundwater table is high, treated stormwater is conveyed to the outlet structure via a perforated underdrain with a cleanout near the split rail fence.
- Overflow:**
  - Outlet Structure:** Runoff volume that exceeds the design storm (1") flows into the domed outlet structure and out to the wetland via a PVC pipe.
  - Level Spreader/Overflow Spillway:** Runoff from extreme storms will flow over the level spreader to the wetland via a reinforced turf overflow spillway.



### 4. Bioretention Areas and Underground Infiltration Chambers

Debris Cleanout	Remove trash and debris from the surface.
Erosion	Signs of erosion gullies, animal burrowing, or overtopping are observed. Repair as necessary.
Sediment/Organic Debris Removal	Remove sediment accumulation and properly dispose when accumulation is greater than or equal to 3 inches.*
Water Draining properly	<p>If standing water is observed in bioretention areas for more than 48 hours after a storm event, rototill or aerate the bottom 6 inches to breakup any hard-packed sediment, and re-plant as needed.</p> <p>Check for leaf litter, debris, and sediment accumulation in overflow outlet structure that impacts inflow to chambers. If accumulation present, schedule cleaning.</p> <p>Check for sediment accumulation and/or standing water that indicates clogging in the chambers. If sediment or standing water is observed in chambers (use <u>inspection ports</u>) for more than 48 hours after a storm event, clean out chambers per manufacturer's instructions in Appendix C.*</p>

**Actions to be taken:**

Figure 3.13. Example site map, function diagram, mow/no mow map, and maintenance description for a bioretention facility.

## Inspections

An inspection program helps to ensure that a stormwater facility remains operational. Inspections should be performed on a regular basis and scheduled based on the specific needs of individual stormwater control types and features. Inspections may be set to occur quarterly or annually, during wet and dry seasons, or after major rainfall events for those components affected by the resulting runoff.

It is not mandatory that all inspectors be engineers, but they should have some knowledge or experience with stormwater systems. Inspections by engineers should be performed where routine inspection has revealed a question of structural or hydraulic integrity affecting public safety. It should be noted that not all inspections can be conducted by direct observation. Subsurface system components may require video equipment, for example, or specialized equipment will be needed for maintenance. The type of equipment needed for inspection and maintenance should be factored into SCM selection and design to ensure that there is adequate access and capacity for maintenance.

The inspection process should document observations made in the field and should include structural conditions, hydraulic operational conditions, evidence of vandalism, condition of vegetation, occurrence of obstructions, unsafe conditions, and build-up of trash, sediments and pollutants. A sample checklist is provided in **Appendix C** that can be used during maintenance inspections.

Bioretention Landscape Maintenance Schedule												
	Jan	Feb	Mar	Apr	May	Jun	Jul	Aug	Sep	Oct	Nov	Dec
Task	Frequency & Time of the Year											
Cutting				X								
Mowing				x	X	x	x	x	x	x	X	x
Weeding				X		X			X		X	
Monitoring				X		X			X		X	
Watering						x	x	x	x			
Seeding				x	x					x	x	
Plant Replacement				x	x					x	x	

"Mow" Areas  
 No "Mow" Areas (Bioretention Areas)  
 All areas

X required  
x as needed

*Sample schedule for landscape maintenance at bioretention (based on temperate climate in northeast US).*

## Scheduled and Corrective Maintenance

Maintenance activities are scheduled or corrective. Scheduled maintenance tasks are those that are accomplished on a regular basis and can generally be conducted without referencing inspection reports. These items typically consist of vegetation maintenance (such as mowing), trash clean up, and debris removal. These tasks are required at well-defined time intervals and should be considered a requirement for most, if not all, stormwater structural facilities. A maintenance crew is typically given a fixed scope of responsibility to address these items.

Corrective tasks consist of items such as sediment removal, slope stabilization, and outlet structure repairs that are done on an as-needed basis. These tasks are typically scheduled based on inspection results or in response to complaints. Corrective maintenance sometimes requires specialized expertise and equipment. For example, the clean out of a proprietary hydrodynamic separator may require a vac truck. Therefore, some maintenance tasks might be effectively handled on a contract basis with an outside entity (and should be accounted for in the annual budget).

Refer to **Chapter 5** for the maintenance requirements of individual stormwater control measures.



*Small maintenance actions like removing buildup at the inlet point may be the one thing needed to keep a practice operational.*

### 3.6. RETROFITS AND REDEVELOPMENT

Improving the management of stormwater runoff from new development will not solve the VI's existing water quality or flooding concerns. Fixing the drainage problems associated with existing development will require retrofitting and improvement of conditions every time a redevelopment opportunity arises. Retrofitting in the VI is not a regulatory mandate, although jurisdictions in the US are beginning to require retrofits to meet TMDLs. Retrofitting is the process by which SCMs are installed to reduce the stormwater impacts from existing developed areas. The objective of retrofitting is to remedy problems associated with old, failing, or absent stormwater systems. Retrofits are typically pursued by the government to mitigate flooding, reduce erosion, or comply with TMDL or other water quality regulatory requirements. Stormwater retrofits can also improve the appearance of existing facilities through landscape amenities and additional vegetation. Space constraints, construction costs, acquisition of easements, safety precautions, economic vitality, and property rights all compete with the need to reduce pollutant loads in the urban environment.

Retrofit designers must work backwards from a set of existing site constraints to arrive at an obtainable, yet acceptable, stormwater solution. As such, permitting agencies may approve retrofit designs that do not fully meet the stormwater standards or performance criteria due to existing site constraints. In fact, Stormwater Standard SW-1 provides a reduced threshold for redevelopment sites compared to new development.

The key to successful retrofit design is the ability to provide pollutant removal, channel erosion protection and flood control while limiting the impacts to adjacent infrastructure, residents or other properties. Designers should avoid the relocation of existing utilities, wetland and forest impacts, and gut and floodplain alterations. They may need to comply with dam safety criteria and provide adequate construction and maintenance access.

Retrofits can vary widely in cost from a few thousand dollars to several hundred thousand dollars. There are many grant opportunities available for retrofits on both public and private properties. To access these funds, designers should look for opportunities to tie



*This ponding basin retrofit was installed to manage flooding on Kingshill Rd. in Coral Bay on St. John.*

projects to impaired waters, habitat restoration, climate resiliency, and underserved communities.

Retrofitting often involves construction of unique or unusual elements, such as flow splitters or diversion structures. Many of these practices may be unfamiliar to contractors. It is a good idea to retain the designer of record to answer contractor questions, conduct regular inspections, and maintain construction records. As-built drawings should also be a part of the construction process for maintenance purposes. Because most retrofits will be undersized, inspection and maintenance becomes even more important compared to their new development counterpart. Access roads, stockpiling, or staging areas may be absent or woefully undersized. Maintenance is vital to ensure that a retrofit functions properly.

Retrofitting techniques can be applied to many different situations and may include some of the following common strategies:

- Source Control Retrofit –LID techniques used to reduce runoff and/or pollutant generation before it enters a drainage system.
- Redevelopment –will result in new SCMs that meet stormwater standards.
- Existing Structural Control Retrofit –retrofit of an existing SCM to improve its pollutant removal efficiency or storage capacity, or both.
- Installation of Additional Stormwater Controls – Additional stormwater controls can be added for existing development or redevelopment.
- Conversion of Existing Stormwater Facilities to Water Quality Functions –modify storage basins to improve water quality treatment.

- Open Channel Retrofit – Open channel retrofits are constructed within an open channel below a storm drain outfall.
- Off-line Retrofit – Involves the use of a flow-splitter to divert the first flush of runoff to a lower open area for treatment in areas where land constraints are not present.
- In-line Retrofit – Used where space constraints do not allow the use of diversions to treatment areas.

**Table 3.8.** lists some site-specific factors to consider in determining the appropriateness of stormwater retrofits for a particular site.

*Table 3.8. Site Considerations for Evaluating Retrofits (adapted from Claytor, 2000)*

Factor	Consideration
<b>Retrofit Purpose</b>	What are the primary and secondary (if any) purposes of the retrofit project? Are the retrofits designed primarily for runoff reduction, flood control, water quality, or a combination?
<b>Construction/ Maintenance Access</b>	Does the site have adequate construction and maintenance access and sufficient construction staging area? Are maintenance responsibilities for the retrofits clearly defined?
<b>Subsurface Conditions</b>	Are the subsurface conditions at the site (soil permeability and depth to groundwater/bedrock) consistent with the proposed retrofit regarding subsurface infiltration capacity and constructability?
<b>Utilities</b>	Do the locations of existing utilities present conflicts with the proposed retrofits or require relocation or design modifications?
<b>Land Use Context</b>	Are the retrofits compatible with adjacent land uses of nearby properties? Do they provide benefits to underserved or EJ communities? Will they reduce coastal or flood hazards or otherwise add to community resilience.
<b>Wetlands, Sensitive Water Bodies, and Vegetation</b>	How do the retrofits affect guts, adjacent or downgradient wetlands, floodplains, sensitive receiving waters, and vegetation? Do the retrofits minimize or mitigate impacts where possible?
<b>Co-Benefits</b>	Are there opportunities to combine stormwater retrofits with complementary projects such as stream stabilization, habitat restoration, or wetland restoration/mitigation? Does the retrofit integrate with recreational improvements? Does the retrofit increase urban tree canopy cover?
<b>Permits and Approvals</b>	Which local, state, and federal regulatory agencies have jurisdiction over the proposed retrofit project, and can regulatory approvals be obtained for the retrofits?
<b>Public Safety</b>	Does the retrofit increase the risk to public health and safety? Do the retrofits add to climate resiliency?
<b>Cost</b>	What are the capital and long-term maintenance costs associated with the stormwater retrofits? Are the retrofits cost-effective in terms of anticipated benefits?



# 4

# EROSION & SEDIMENT CONTROL PRACTICES

<b>4.1</b>	<b>SEDIMENT BARRIERS</b> .....	<b>4-3</b>
	Limits of Disturbance (LOD) .....	4-4
	Tree and Buffer Protection.....	4-6
	Stabilized Construction Entrance .....	4-8
	Brush Berms.....	4-11
	Compost Filter Socks .....	4-12
	Silt Fence.....	4-14
	Turbidity Curtain .....	4-19
<b>4.2</b>	<b>STABILIZATION PRACTICES</b> .....	<b>4-21</b>
	Surface Roughening .....	4-22
	Temporary Seeding/Planting .....	4-25
	Mulching .....	4-32
	Erosion Control Blankets .....	4-33
	Retaining Walls/Soil Bioengineering .....	4-36
<b>4.3</b>	<b>DIVERSIONS &amp; CONVEYANCES</b> .....	<b>4-43</b>
	Diversion Berms and Swales .....	4-44
	Pipe Slope Drains.....	4-46
	Check Dams .....	4-48
	Vegetated and Lined Waterways .....	4-51
	Temporary Diversions & Isolations .....	4-54
<b>4.4</b>	<b>SEDIMENT TRAPPING DEVICES</b> .....	<b>4-56</b>
	Sediment Traps.....	4-58
	Sediment Basins .....	4-61
	Dewatering Devices.....	4-66
<b>4.5</b>	<b>INLET &amp; OUTLET PROTECTION</b> .....	<b>4-71</b>
	Inlet Protection Devices .....	4-72
	Outlet Protection .....	4-78
	Level Spreaders .....	4-85
<b>4.6</b>	<b>UNPAVED ROAD PRACTICES</b> .....	<b>4-87</b>
	Grade Breaks .....	4-89
	Broad-based Dips.....	4-90
	Cross-drains and Culverts .....	4-94
	Waterbars .....	4-97
	Turnouts .....	4-100
	Geosynthetics.....	4-102
	Surface Stabilizers .....	4-104

Land is never more vulnerable than when it is cleared and graded during construction. Soil particles are easily mobilized and can travel long distances during heavy rains, particularly in the VI where there are steep slopes, fine soils, and miles of unpaved roads. Fortunately, erosion and sediment can be controlled on construction sites and unpaved roads using relatively simple methods at minimal cost. The Erosion and Sediment Control (ESC) practices described here are grouped by function into six general categories (Figure 4.1).

This chapter provides design criteria and standard details for ESC practices, plan requirements, general installation and maintenance procedures, and troubleshooting guidance. Calculations and look up

tables are provided, where applicable. Given the variability of site conditions and construction activities, this information is not intended to be all encompassing; rather it should provide enough information for designers, contractors, and permitting agents to implement and maintain most ESC practices. Large sediment basins, culverts, and walls over 4 feet in height, for example, will require a higher level of design to ensure structural integrity and safety.

Effective ESC is as much an art as it is a science. Rarely will ESC plan implementation be perfect and without adaptation. It is important to provide redundancy in ESC by using multiple practices.



Figure 4.1 The six functional categories of ESC practices



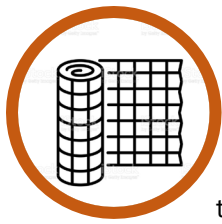

## 4.1 SEDIMENT BARRIERS

Sediment barriers and perimeter controls are materials or practices that are specifically designed to prevent clearing, limit access, and keep sediment-laden runoff, from leaving the project site or a smaller localized area, such as a stockpile. They are temporary practices, are the first practices installed on a site (even before clearing), and generally require the most frequent inspection and maintenance. Perimeter controls should be carefully selected based on the type of project, site constraints, and maintenance commitment. Practices include:

- **Limits of Disturbance:** High visibility fencing or flagging installed prior to any clearing activity that is used to mark the boundary of allowable work.
- **Tree and Buffer Protection :** High visibility construction fencing, or other barrier used to protect trees and other resource areas within the limit of disturbance from accidental damage by machinery.
- **Stabilized Construction Entrances:** Rock pad or other rough surfacing that knocks sediment off tires. They are used to prevent vehicles from tracking sediment off site onto public roads or adjacent paved areas.
- **Brush Berms:** Cleared vegetation strategically stacked within the limits of disturbance to form a tightly-packed, but permeable berm to slow runoff.
- **Filter Socks:** Flow-through practices used instead of silt fences that slow and filter runoff rather than allowing it to pond behind practice. They are not intended to pond water behind them, thus do not need to be more than a foot high.



*Sediment barriers are perimeter controls used to define the extent of work, protect trees and natural areas from damage, and prevent offsite sedimentation.*

- **Silt Fencing:** Staked fabric fencing to block runoff from leaving the area. Silt fences work by ponding water behind the fence and allowing sediment to settle out, therefore they must be properly trenched in and secured with stakes to hold back flows. They do not filter runoff through the fabric, though weeping may occur.
- **Turbidity Curtains:** Flexible, floating barrier used to contain suspended sediment within a waterbody. This should be considered the last line of perimeter defense and be used in tandem with upland perimeter controls.

**Table 4.1** provides a simple selection matrix for comparing the relative benefits of individual practices. Contact DPNR for assistance in determining if other techniques not included here (paving, chemical binders, etc.) are acceptable.

*Table 4.1 Summary of sediment barriers and their benefits.*

Benefits	Limits of Disturbance	Tree and Buffer Protection	Stabilized Construction Entrance	Brush Berm	Filter Socks	Silt Fencing	Turbidity Curtains
Low maintenance	●	●		●	●		
Easy to install	●	●	●		●		
Inexpensive	●	●	●	●		●	
Reduces runoff/exposed soil	●	●	●				
Aesthetics	●	●	●				
Good for in-water projects							●
Habitat protection	●	●		●			

## LIMITS OF DISTURBANCE (LOD)

Any ground disturbance on a site can result in increased erosion and, often more area is disturbed than needed. Preserving natural vegetation on the site by clearing only the area where structures will be built is the most effective ESC practice. Only those areas essential for construction activities should be cleared (building footprints, road/driveways, cistern and septic system areas). All other vegetated areas should remain undisturbed, particularly steep slopes; highly erodible soils; or areas around guts, ponds or coastal waters. This minimizes erosion potential, protects water quality, provides aesthetic benefits, and is cost-effective in the long term. The undisturbed vegetation remaining on the site also works as a filter to trap sediments and other pollutants. A natural vegetation zone around the building area will also provide a windbreak, shade, privacy barrier, noise buffer, dust filter, and wildlife habitat.

The limits of disturbance (LOD), or limit of work, is the physical marker of the boundary between areas that will be disturbed during construction (e.g., cleared, graded) and areas that will remain in their existing condition. The limit of disturbance should be clearly denoted in the construction drawings and be marked in the field prior to site clearing. Typically, orange safety fencing, flagging, silt fencing, or other highly visible barrier is used to mark the limit of disturbance and alert workers. Use signage in multiple languages.

### Minimum Plan Requirements

Details of the LOD shall be shown on the plan and contain the following items:

- Locations clearly marked on site plan
- Type and size of visible barrier
- Installation methodology
- Type and maximum spacing of fence posts
- Type and wording for signage, if applicable
- Topsoil stockpiling requirements
- Maintenance and removal requirements

### Design

1. Gather property boundary, topography, vegetation and soil information. Identify potentially high erosion areas, areas with tree wind-throw potential, etc. Show the vegetative cover types on the existing conditions plan as well as other natural and manmade features. Identify vegetation desirable for preservation because of value for



*Orange safety fencing denoting the limit of disturbance.*



*Without a visible demarcation of limits of disturbance, site clearing can unintentionally occur beyond the approved boundary.*

screening, shade, erosion control, endangered species, tree health and lifespan, space for growth, and aesthetics.

2. Delineate LOD clearly on engineering plans along with details of effective practices to demarcate that limit in the field. Avoid construction on steep slopes (slopes > 40%), highly erodible soils, wetlands and guts.
3. Identify trees **>6 inches** in diameter to be cut on the plans. Trees that may be a hazard to people, personal property or utilities shall be designated for removal. Contact the Department of Planning and Natural Resources (DPNR) Division of Fish & Wildlife for information on rare or endangered species before proposing to remove trees or other vegetation.
4. Identify areas to be seeded and planted. Remaining vegetation shall blend with surroundings and/or provide special function such as a filter strip, buffer zone or screen.

5. Since soil depth is so shallow in the VI, topsoil is a valuable commodity and should be thoughtfully conserved. Topsoil removed during site grading should be stockpiled onsite so that it can be reused after construction. Soil stockpiles must be temporarily seeded or covered with a tarp, ESC mat, or temporary seeding to prevent erosion. The compatibility of existing and imported topsoil should be checked to ensure maximum growth potential for the desired vegetation.

## Installation

Heavy equipment can overly compact the topsoil and destroy desirable plants. The proposed limits of disturbance should be physically marked off to ensure that only the required land area is cleared. Clearing promotes unwanted weed growth because of increased exposure to sunlight. Hard-to-control plants like guinea grass, vines, tan-tan and casha can rapidly take over cleared areas. Hand-clearing will help preserve the existing vegetation while removing unwanted plants.

1. Before clearing, mark areas to be preserved use temporary wood fencing, plastic construction fencing, flagging, and/or signage.
2. Install fencing along the limit of work as shown in the construction drawings, which may be along property boundary, preserved areas (e.g., buffers), archeological sites, etc.
3. Locate temporary roadways, material stockpiles, and staging areas to avoid vegetation and prevent unnecessary or accidental clearing.
4. Prohibit heavy equipment, vehicle traffic, and storage of construction materials within protected areas. Most importantly, instruct all site personnel to honor protective devices.

## Maintenance

- During construction, the limits of disturbance should remain clearly marked at all times.
- Verify that protective measures remain in place and restore damaged protection measures immediately.
- Serious tree injuries should be attended to by a tree specialist, especially damage to large and/or important native trees.

## Troubleshooting

- Brush berms created using debris from site clearing do not constitute adequate limits of disturbance since they are by their very nature created after disturbance has occurred.
- Often, the LOD is not installed in the correct location per design plans. Verify placement prior to clearing.
- No LOD was installed at all. This could lead to clearing in designated protected areas.
- Limits are not clearly marked. Make sure to use highly visible signage and fencing and repair any damage immediately after it is noticed.
- Sediment discharges into protected areas. Remove sediment and install additional practices.

**Warning!** Heavy equipment operators should not begin site clearing until the LOD has been installed. Excessive site clearing creates an additional burden on the contractor to stabilize exposed soils and manage erosion.

## TREE AND BUFFER PROTECTION

The preservation of natural vegetation (existing trees, vines, bushes, and grasses) provides a buffer that can slow runoff and filter sediment around and within the site, as well as providing soil stabilization, shade, habitat, and carbon sequestration. Existing trees, inside the limit of disturbance that will not be removed will need protection from accidental damage during construction. Tree and buffer protection involves the installation of temporary, high-visibility, and sturdy fencing or other barrier to prevent equipment operators from nicking trunks, damaging low lying branches, and stockpiling or grading close to roots.

Virgin Islands Law Title 12 Chapter 3 prohibits the cutting or injury of any tree or vegetation within 30 ft of the center, or 25 ft from the edge, of a watercourse. Title 12 Chapter 3A outlines cutting requirements for heritage trees, nuisance trees, and tree canopy on public lands. Tree protection is particularly beneficial in or near floodplains and steep slopes where existing vegetation helps prevent erosion, provide shade, maintain water quality, and offer habitat for endangered or threatened plant and animal species.

### Minimum Plan Requirements

Details of tree and buffer protection shall be shown on the plan and contain the following items:

- Regulated buffer setbacks to wetlands, guts, steep slopes, and important/protected habitats
- Locations, sizes, and types of existing trees and/or vegetation to be protected on site
- Location and type of protection fencing
- Installation, maintenance and removal requirements.

### Design

On-site vegetation preservation should be planned before any site disturbance begins. Good site management is needed to minimize the impact of construction on existing vegetation.

1. Plan for limits of disturbance (LOD), tree protection, and/or buffer protection at regulated wetland, gut, and shoreline setbacks (25 ft minimum setback).
2. Identify groups of trees or individual specimens for protection inside the LOD. Consult with certified arborist on heritage trees or trees on public lands.
3. To prevent vehicles or machinery from operating over the root zone or damaging the trunk, the

Chapter 4. ESC Practices



Bright orange construction fencing used for tree protection should be protective of trunk and roots.



What is the purpose of this fencing?

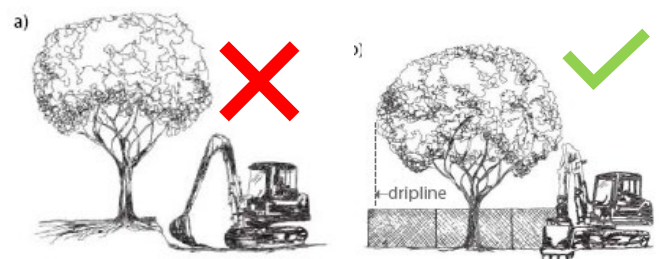

Figure 4.2 (Top) Do not trench or excavate within the root zone of trees. (Bottom) Install tree protection fencing beyond the dripline of the tree(s) (Source: Auckland, 2009).

protective fencing radius should extend to the canopy dripline, which is generally the distance that branches (and roots) extend beyond the tree trunk (**Figure 4.2**).

Alternatively, allow 1.5 ft for every inch of trunk diameter as follows:

*For a tree with 10-inch trunk,  
10 X 1.5 ft= 15 ft radius*

4. Temporary fencing must be visible, sturdy, and designed appropriate to the degree of construction activity taking place at the site. Ideal materials include 2x4 wood framing, metal posts, and orange safety fencing.
5. Do not excavate within the canopy dripline or buffers. Excavating inside the dripline can sever roots, cause structural instability, and lead to hazardous situations (shifting or falling trees).
6. Limit soil placement over existing tree and shrub roots to a maximum of 3 inches. Retaining walls, tree wells, or terraces should be used to protect roots of trees and shrubs when grades are lowered. Lowered grades should start no closer than the tree's dripline.

### Installation

1. Trees to be preserved should be clearly marked in the field **BEFORE** clearing to protect from ground disturbances around the base of the tree.
2. Install fencing per the plans, but at a minimum, outside of the tree's dripline.
3. Care should be taken to minimize damage to tree limbs and root systems.
4. Instruct workers to honor protective devices.
5. Prohibit equipment, vehicles, or storage of construction materials within protected area(s).
6. Do not remove until site cleanup and final stabilization is complete.

### Maintenance

- During construction, tree protection should remain clearly marked at all times.
- Inspect daily to verify that protective measures remain in place.
- Restore damaged protection measures immediately. Serious tree injuries shall be attended to by a tree specialist.

### Troubleshooting

- Tree shields wrapped directly around the trunk don't fully protect roots or branches. Install construction fencing at dripline or an adequate distance from trunk.
- If trunks are scraped by equipment, have an arborist evaluate the tree. Remove tree if it is not expected to survive. Replant one or more trees as needed to compensate for loss.
- Large tree roots are cut or exposed. Remove the ends of exposed roots with a smooth cut, and then cover over roots with soil. Extend fencing.



(Top) fencing not protective of trees; (Middle) vegetative clearing and construction activity within the 25 ft buffer to gut is legally prohibited. (Bottom left) accidental tree damage from backhoe; and (Bottom right) tree protection signage on wooden fencing.

- Soil is severely compacted over roots from heavy equipment. Aerate the soil by punching holes 12 inches deep and 18 inches apart.

## STABILIZED CONSTRUCTION ENTRANCE

A stabilized construction entrance is a temporary crushed rock (or other rough surface) pad located at all points where vehicles enter or leave a construction site. The purpose of a stabilized entrance is to reduce the tracking of sediment/mud from the site onto roads or adjacent offsite paved areas by knocking sediment off vehicle tires leaving the site.

### Minimum Plan Requirements

- Location(s)
- Type and size of stone
- Width and length of entrance
- Type of filter fabric
- Maintenance and removal requirements

### Design

1. **Location:** A stabilized construction entrance should be installed at every point where traffic enters or leaves a construction site and before construction begins. If site entrance and exit are in different locations, a stabilized entrance should be placed at both locations. Vehicles leaving the site should travel over the entire length of the stabilized entrance. Stabilized construction entrances should not be used on existing pavement. For individual home sites, the construction entrance should be located where the permanent driveway will be sited.
2. **Length and Width:** Stabilized entrances should be wide and long enough so that the largest construction vehicle will fit in the entrance. Most sites need the entrance to be a minimum of 50 feet long (30 feet for an individual home site) and 12 feet wide with a flare to provide a turning radius (**Figure 4.3**).
3. **Material:** Stone, rock or gravel (2" – 3") or recycled concrete equivalent (RCE) should be placed at least 6 inches deep on top of the geotextile over the length and width of the entrance. The ends of the stabilized construction entrance should be tapered to meet the grade and orientation of the street.
4. **Geotextile:** The filter fabric used shall be resistant to commonly encountered chemicals, hydrocarbons, mildew, rot and rodents, and conform to the properties listed in **Table 4.2**.

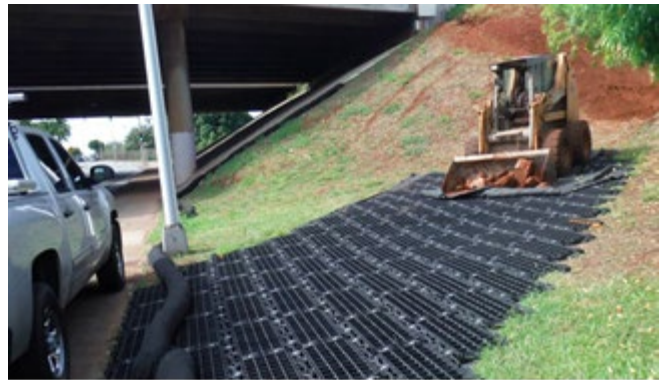

Properly stabilized stone construction entrance (photo source University of Illinois) and construction entrance mat (from stormwaterhawaii.com).

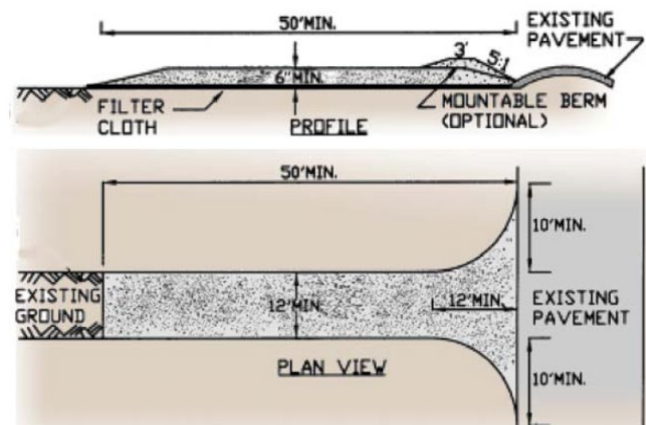

Figure 4.3 Standard detail and profile of stabilized construction entrance.

5. **Surface Water:** Pipe all surface water flowing to or diverted toward construction entrances underneath the entrance. Protect the pipe installed under the construction entrance with a mountable berm. Size the pipe according to the drainage, with a minimum diameter of 6 inches. If piping is impractical, a mountable berm with 5:1 slopes may be used.
6. **Alternative:** An alternative to a stone entrance is a reusable construction mat, made of durable

material that helps break loose sediment from tires and equipment tracks.

7. **Add-ons:** A possible addition to stone or mat construction entrances is the use of tire wash stations. This addition is particularly useful as stone entrances get clogged, or if limestone is used for the entrance pad and becomes impervious over time.

## Installation

1. Locate entrance for maximum use by all construction vehicles.
2. Place geotextile over the existing ground prior to placing stone (see **Table 4.2** for fabric specifications for heavy duty vs. light duty roads). Geotextile is not necessary for single-family residences.
3. When necessary, wheels shall be cleaned to remove sediment prior to leaving the site. If a tire wash area is required, drainage should be directed to a sediment trap rather than storm drains, ditches, or watercourses.

## Maintenance

- The condition of the stabilized entrance should be monitored throughout the duration of the project to prevent tracking or flowing of sediment onto rights-of-way. If sediment is being tracked offsite and onto the road, then the entrance is failing. A mountable berm where the entrance meets the road should be constructed, if needed, to further trap sediment.
- If the crushed stone or recycled/reclaimed concrete becomes clogged with sediment or solidifies, top dressing of additional rock should be added. Install tire wash as needed.
- Street sweeping on paved roads should be done every day. All sediment spilled, dropped, or washed onto public rights-of-way must be removed immediately and more rock added to the entrance as needed.
- If vehicles are bypassing the entrances, install barriers such as construction fencing to prevent vehicle bypass, or add/enlarge a flared entrance.

## Troubleshooting

The following problems related to stabilized construction entrances can lead to increased sedimentation:



*Washing tires of construction vehicles can be a good way to prevent sediment from leaving the site. Tire washes should be designed to manage muddy water.*



*Sediment tracking onto road and buildup shows that this entrance has not been maintained (Guam EPA).*

- Compaction of rocks in stabilized entrance. Install layer of fabric underneath rock and reapply rock.
- Rock entrance is full of sediment. Top-dress with additional rock and/or wash the rock and drain the wash water to a sediment trapping device.
- Bypassing of entrance by vehicles. Taper construction entrance to the edge of street, expand entrance width, and/or install barriers to direct all traffic to entrance.

Table 4.2 Geotextile properties for stabilized entrance (Empire State Chapter Soil & Water Conservation Society, 1997).

Fabric Properties <sup>1</sup>	Light Duty <sup>2</sup> Roads Graded Subgrade	Heavy Duty <sup>3</sup> Haul Roads Rough Graded	Test Method
Grab Tensile Strength (pounds)	200	220	ASTM D1682
Elongation at Failure (%)	50	60	ASTM D1682
Mullen Burst Strength (pounds)	190	430	ASTM D3786
Puncture Strength (pounds)	40	125	ASTM D751 (modified)
Equivalent	40 - 80	40 - 80	US Std. Sieve
Opening Size	--	--	CW-02215
Aggregate Depth (inches)	6	10	--

<sup>1</sup> Fabrics not meeting these specifications may be used only when design procedure and supporting documentation are supplied to determine aggregate depth and fabric strength.

<sup>2</sup> Light Duty Road: Sites graded to subgrade and where most travel would be single axle vehicles/occasional multi-axle truck.

<sup>3</sup> Heavy Duty Road: Sites with only rough grading, and where most travel would be multi-axle vehicles.



## BRUSH BERMS

Brush berms are a temporary barrier constructed at the perimeter of a disturbed area or strategically placed below or across a slope using debris left over from site clearing and grubbing (e.g., small tree branches, root mats, stone, or other debris). Brush barriers can be used to slow flows and retain sediment from small, disturbed areas. Perhaps of greater value are the habitat, water absorption, and waste stream diversion benefits. Additionally, they will biodegrade over time leaving valuable organics on site. Brush berms should not be relied on to filter sediment from runoff. Brush berms can be used on mild slopes but should not be used where flows are concentrated.

### Minimum Plan Requirements

The location of proposed berms in relation to limits of disturbance and other controls should be shown on the site plans and included in construction schedule.

### Design

1. Use below disturbed drainage areas < 0.25 acre per 100 ft of barrier length. The drainage slope to a brush barrier must be flatter than 2:1 and less than 100 ft. This practice is not intended for areas of high volume or concentrated flows.
2. 3 ft maximum berm height; 5-15 ft base width.
3. Base of berm should consist primarily of materials of >6-inch diameter or greater.

### Installation

1. Installed inside the limits of disturbance.
2. Trench large logs into the ground 3-6 inches to create the base of the berm and improve ponding potential.
3. Hand place or use equipment to tightly pack branches, stones, and cuttings to improve filtering capacity and debris storage.

### Maintenance and Troubleshooting

Brush barriers are fairly stable and composed of natural materials, so maintenance requirements are minimal.

- Make sure berms retain their initial configuration and ponding/filtration/flow function.
- Look for scouring downslope of berms where ponded overflows occur. Check berms and look for washouts, undercutting (e.g., animal



*Brush berms consist of logs and tightly woven branches that can help slow runoff velocities.*

- burrows), and end bypasses. Fill gaps with additional debris, sediment, and stone.
- Allow berm to rot overtime.

## COMPOST FILTER SOCKS

Compost filter socks (CFS) are long tubes of absorbent materials such as wood chips, organic mulch, or compost contained within a strong geotextile, mesh "sock." These are "flow-through" devices that allow water to flow through them while the fill material filters out sediment. Therefore, clearer water flows through the other side of the sock with little reliance on ponding. These practices don't require trenching and are easier to install and maintain than silt fences. They can be used on disturbed or undisturbed ground, pavement, along site perimeters, and as check dams and inlet protection. In addition, they can be moved, reused, or cut open at end of life.

### Minimum Plan Requirements

Details of the filter sock shall be shown on the plan and contain the following items:

- Locations on site
- Type and size of filter sock
- Type and source of filter media
- Installation methodology
- Type and maximum spacing of stakes, as needed
- Maintenance and removal requirements

### Design

1. CFS vary in size and material but are commonly a 12-24" diameter filled with compost. **Table 4.3** provides guidance on spacing and sock diameter on a given slope. The effective sock height in the field will be slightly less than tube diameter.
2. CFS should be placed perpendicular to stormwater flow. If used on a slope, they should be placed 5 ft beyond the toe of the slope to allow space for sediment deposition. Ends of the CFS segments shall be turned upslope to minimize run around.
3. Overlap connecting ends 2-3 ft and connect mesh with zip or wire ties. 1.5" square wooden stakes or steel posts can be used for staking.
4. Select photodegradable or biodegradable mesh.
5. Straw wattles are not recommended substitutes since they do not hold up well to heavy flows.

Other Applications:

- If used as a check dam, the center of the CFS shall be a minimum of 6 inches below the ends tying into swale banks.



*(Top) Compost socks filter fine sediments from runoff (photo: Pacific Unlimited); (Bottom) straw filled wattles do not hold up well and offer minimal filtering benefit.*

- If used as a drain inlet protector, CFS shall fully enclose the drain. If used as a curb inlet protector, compost filter socks shall not be higher than the height of the curb.
- If used as a dewatering device, the CFS shall be placed in a ring to fully enclose effluent.
- CFS may be seeded for permanent and in situ biofiltration applications.

### Installation

1. Depending on supplier, CFS can be transported prefilled in pallets or can be filled on site by hand or with a blower attachment. Follow all manufacturer's instructions.
2. Ensure all debris is removed where a sock will be placed. You may need to backfill on the uphill side of the sock if ground contact is uncertain.
3. CFS should be supported by stakes driven 8-12" into ground every 5-10 ft, depending on material, surface condition, construction activity, and slope. Stakes can be placed through the sock, behind, or crossing from either side of sock to hold it in place (**Figure 4.4**).

## Maintenance

Follow the manufacturer’s maintenance instructions. Like silt fence, filter socks should be monitored daily throughout the project and especially around heavy rain events. Sediment accumulated behind these materials should be removed when reaching ½ sock height. Alternatively, install a second row of sock positioned on top of or up slope of the original sock. Extra filter sock and support materials should always be available onsite for unexpected repairs and replacements. Once the site is permanently stabilized, the filter sock can be opened, and fill media spread on site or removed and disposed of properly.

## Troubleshooting

- Torn, flattened, or clogged socks should be mended or replaced.
- The compost filter sock does not have good ground contact allowing stormwater to flow under the practice. Remove sock, remove debris from ground surface and reinstall.
- Sock is overtopped by runoff. Stack it, replace with larger diameter, or reduce total area draining to sock.

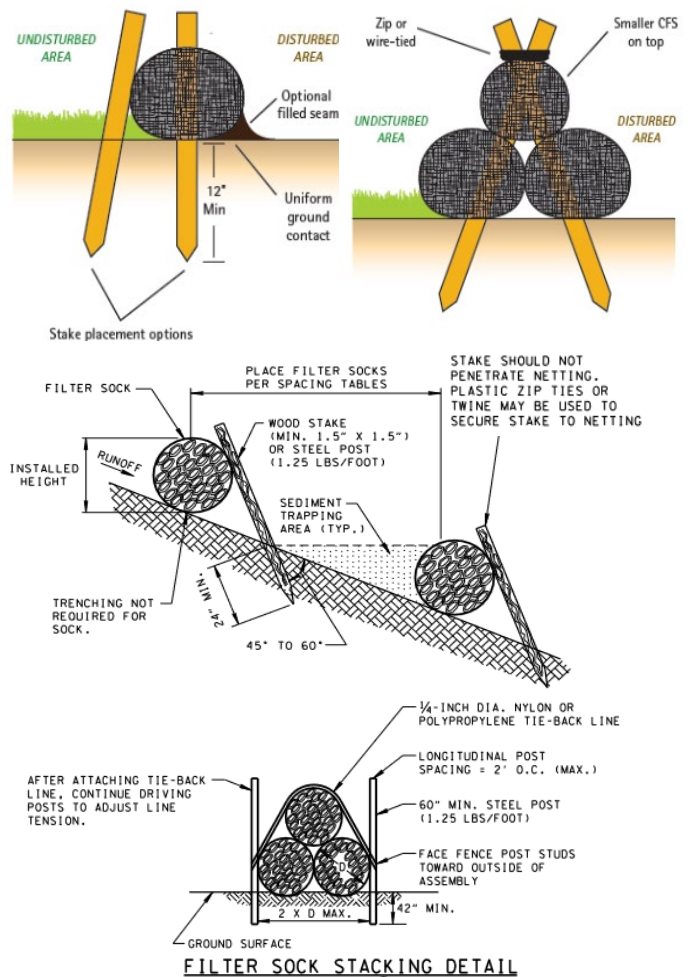

Figure 4.4 Compost filter sock (CFS) details showing staking and stacking options (from MKB Stormwater Innovation and TNDOT).

Table 4.3 Compost filter sock slope, length, and diameters (from Filtrexx Design Manual v 11.1)

Slope Percent	Maximum Slope Length Above Sediment Control in Feet (meters)*					
	5 in (125 mm) Sediment control	8 in (200 mm) Sediment control	12 in (300 mm) Sediment control	18 in (450 mm) Sediment control	24 in (600mm) Sediment control	32 in (800mm) Sediment control
	4 in (100 mm)**	6.5 in (160 mm)**	9.5 in (240 mm)**	14.5 in (360 mm)**	19 in (480 mm)**	26 in (650 mm)**
2 (or less)	360 (110)	600 (180)	750 (225)	1000 (300)	1300 (400)	1650 (500)
5	240 (73)	400 (120)	500 (150)	550 (165)	650 (200)	750 (225)
10	120 (37)	200 (60)	250 (75)	300 (90)	400 (120)	500 (150)
15	85 (26)	140 (40)	170 (50)	200 (60)	325 (100)	450 (140)
20	60 (18)	100 (30)	125 (38)	140 (42)	260 (80)	400 (120)
25	48 (15)	80 (24)	100 (30)	110 (33)	200 (60)	275 (85)
30	36 (11)	60 (18)	75 (23)	90 (27)	130 (40)	200 (60)
35	36 (11)	60 (18)	75 (23)	80 (24)	115 (35)	150 (45)
40	36 (11)	60 (18)	75 (23)	80 (24)	100 (30)	125 (38)
45	24 (7)	40 (12)	50 (15)	60 (18)	80 (24)	100 (30)
50	24 (7)	40 (12)	50 (15)	55 (17)	65 (20)	75 (23)

\* Based on a failure point of 36 in (0.9 m) super silt fence (wire reinforced) at 1000 ft (303 m) of slope, watershed width equivalent to receiving length of sediment control device, 1 in/24 hr (25 mm/24 hr) rain event.

\*\* Effective height of Sediment control after installation and with constant head from runoff as determined by Ohio State University.

## SILT FENCE

A silt fence is the most widely used (and misused) sediment barriers. A silt fence is made of geotextile or filter fabric stretched across wood posts, rebar or a wire support fence. The purpose of a silt fence is to temporarily pond muddy runoff behind it, allowing time for the sediment to settle out and the water to either infiltrate in the ground or evaporate. While some water will filter out through the geotextile fabric, the pore spaces bind or clog up with sediment quickly, therefore, the fence does not act as a filter. If not installed correctly (i.e., trenched properly into the ground or supported with staking), the silt fence will not pond water and will fail.

A silt fence is often installed below disturbed areas, on slopes, or around soil stockpiles. It can be installed along the site perimeter, but in uphill settings, only functions to prevent off-site runoff from coming on to the site or to demarcate the limit of disturbance. Silt fences are only effective for removing sediment from overland flow.

### Minimum Plan Requirements

Details of the silt fence shall be shown on the plan and contain the following items:

- Type, size and maximum spacing of fence posts
- Size of woven wire support fences if needed
- Type of filter fabric
- Method of anchoring the filter fabric
- Method of fastening the filter fabric to the fence support
- Installation methodology
- Maintenance and removal requirements

### Design

1. **Fence Posts:** Posts should be a minimum of 36 inches long. Instead of wooden posts, 3/8" - 1/2" steel rebar stakes are recommended in the USVI on slopes >20% or in stony or clayey soils. Silt fences installed on slopes greater than 40% should include wire mesh backing to prevent the fence from being knocked down by heavy stormwater flows (**Figure 4.5**).
2. **Wire Fence:** Woven wire fencing for reinforced silt fences shall be a minimum 14½-gage with maximum 6-inch opening.
3. **Silt Fence Fabric:** Use a woven geotextile with a minimum filtering efficiency of 75 – 85%,



*Silt fence is the most common sediment barrier and perimeter control, but also the most difficult to install and maintain over time.*

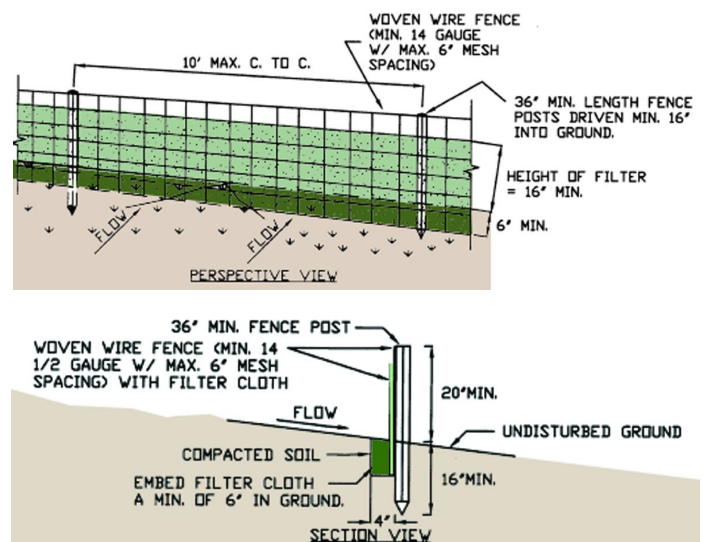

*Figure 4.5 Silt fence details (perspective and section views; Empire State Chapter Soil & Water Conservation Society, 1997).*

minimum standard tensile strength of 30 pounds/linear inch, and a minimum extra tensile strength of 50 pounds/linear inch at a maximum elongation of 20%. The fabric shall be resistant to commonly encountered chemicals, mildew, rot, insects, and rodents.

4. **Pre-fabricated Fencing:** Pre-fabricated silt fences with posts attached are commercially available. While this type of fence is cheaper, it is more difficult to install correctly, particularly in stony or clayey soils.
5. **Placement:** When placing silt fences, use the following design guidance:
  - A silt fence is **NOT** appropriate for controlling runoff from a large area (>5 acres). Maximum drainage area for overland flow to a silt fence

should not exceed ½ acre per 100 feet of fence.

- Do not simply place around the perimeter as there may be too much drainage coming to a lower portion of the site. Consider use of j-hooks and tiebacks to help break up flow and provide redundancy (**Figure 4.6** and **Figure 4.7**).
- Do NOT use silt fences to retain sediment from concentrated stormwater flow (such as in a channel, gully, gut or other drainage way). The material is not designed and manufactured to withstand the force of concentrated flows.
- They should be used in combination with other erosion and sediment control practices, such as temporary seeding, perimeter berms and swales, sediment traps, etc.
- Install perpendicular to the flow direction, generally following the contours of the land. The ends should be slightly turned uphill to prevent water bypassing around the fence.
- Fencing should be placed close to the disturbed area, but approximately 10 feet from the toe of a slope to allow for sediment build up and maintenance access. The area beyond the fence should be undisturbed or stabilized unless used in a series down a slope or around a stockpile.
- Silt fences MUST be anchored and trenched into the ground or else they will fail.
- On long, shallow slopes, you may need to install multiple rows of silt fence to provide adequate protection. The distance between the rows of fencing is dependent on the slope of the site (**Table 4.4**).

*Table 4.4 Distance between rows of silt fence based on slope.*

Slope Steepness	Maximum Length (ft)
2:1	25
3:1	50
4:1	75
5:1 or flatter	100



*Silt fence or other sediment barrier should be installed around stockpiles.*



*(Top) Properly installed silt fence. (Bottom) Fencing improperly installed—no trenching, incorrect fabric, and too close to the stream/gut.*

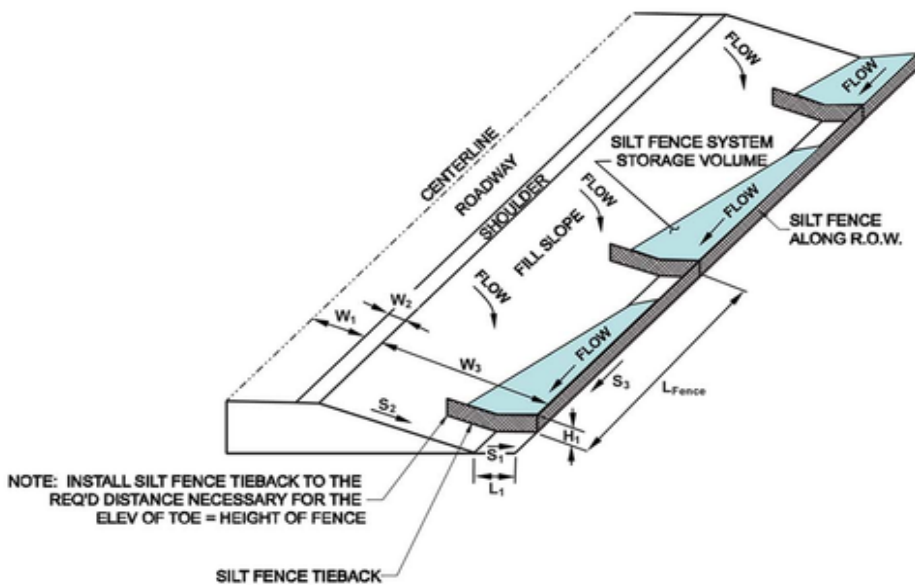
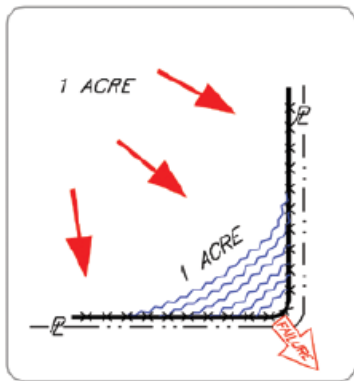
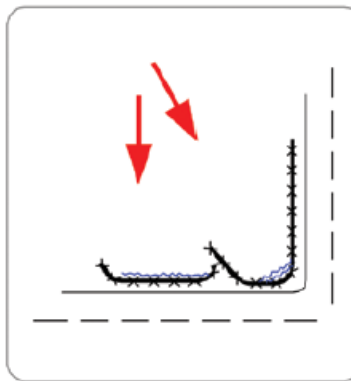

Figure 4.6. Silt fence tieback installation for linear roadway project (Zech et al., 2007)



*Incorrect - Do Not layout "perimeter control" silt fences along property lines. All sediment laden runoff will concentrate and overwhelm the system.*



*Correct - Install J-hooks*

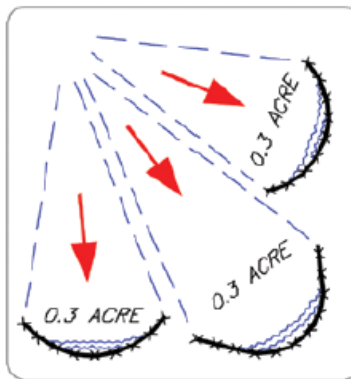
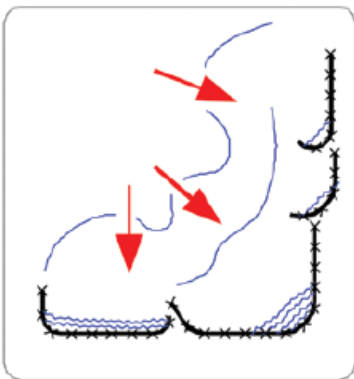

*Discreet segments of silt fence, installed with J-hooks will be much more effective.*

Figure 4.7 Silt fence placement for perimeter control (from Kentucky Construction Site BMP Planning and Specifications Manual, Source Salix Applied Earthcare)

## Installation

Properly installed and used in conjunction with a suite of other ESC measures, silt fence can be an effective sediment barrier. However, silt fences often fail due to improper installation.

1. Silt fences should be installed prior to earth change activities.
2. The fence should be placed away from the bottom of the slope (to increase holding capacity), along a line of uniform elevation perpendicular to the direction of flow.
3. Silt fence material MUST be trenched into the ground to work properly **Figure 4.8**. To install silt fencing properly, you must first dig a 4-inch wide by 6-inch deep trench. Then, hammer in posts at least 16 inches deep, every 5 to 10 feet on the *downhill* side of the trench.
4. Once the trench is dug and the posts are installed, the geotextile fabric should be placed along the bottom of the trench. The fabric should then be attached to the posts with wire or plastic ties every half foot of the post. At the ends of the fence row, fold and tie posts together to overlap the fabric.
5. To complete the installation process, the trench must then be backfilled with soil and compacted. Most fabric comes with lines 6" from the edge. At the bottom of a properly installed silt fence, this line should be buried.
6. In some cases, the fabric should be reinforced with heavy wire to prevent collapse. Fasten woven wire fence securely to the upstream side of the fence posts by staples or wire ties spaced every 24" at top- and mid- sections. Then, staple or securely fasten the filter fabric to the upstream side of the woven wire.

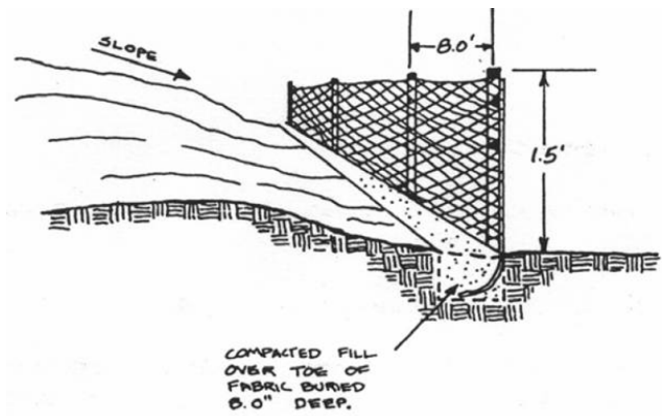

*Figure 4.8 Proper silt fence installation requires 6-inch-deep trenching making it difficult to install. Most fencing comes with a line printed on the fabric indicating depth of burial.*

## Maintenance

- As with installation, maintenance of silt fence is essential to its success at preventing sediment from leaving the site.
- Silt fences should be monitored daily throughout the duration of the project, and especially around the time of heavy rain events.
- If sagging, flapping, or bulging of the fence is observed, you must repair it immediately. Add more stakes and retrench if necessary.
- Extra silt fence materials should always be available onsite for unexpected repairs.

- You must remove sediment and debris when build up reaches **1/3 the height** of the fencing.
- Even if the site is inactive, continue to inspect the fence for issues after every rain event.
- Once site is permanently stabilized, the silt fence should be removed and disposed of properly.

## Troubleshooting

**Figure 4.9** illustrates common reasons why silt fences fail.

- Silt fence is not maintained. Inspect your silt fence daily to detect problems. Remove

accumulated sediment and replace torn fabric immediately.

- Fabric is not trenched properly during installation. If the trenching was not done properly, you must reinstall the entire silt fence to prevent flow from going underneath.
- Stakes are placed on uphill side of the fence. You must reinstall the stakes on the downhill side, at intervals of 5 to 10 feet.
- Silt fence is installed across an area of concentrated flow (e.g., swale or stream). Identify the source of the concentrated flow and re-evaluate placement of the silt fence. A different ESC practice may be needed.
- Flow overtops or bypasses the fencing. Add uphill row of fencing, add wire support, and/or turn ends of fencing uphill.
- Silt fence never removed from site after final stabilization, creating an eyesore or even a runoff/erosion issue.



(Left) Silt fences are not effective in ditches. (Right) Use multiple rows of fencing if needed for large drainage areas or to add a level of needed protection.

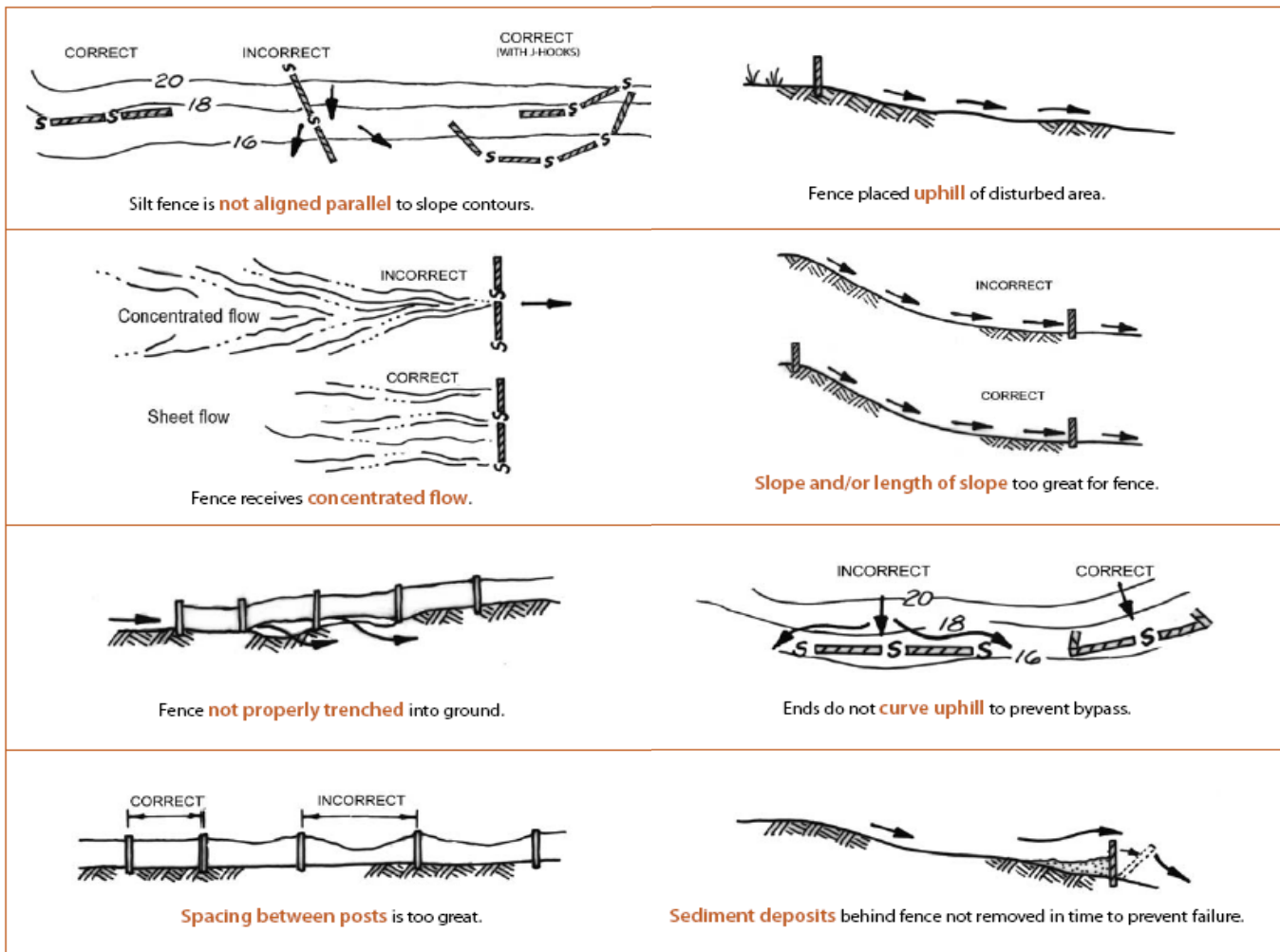

Figure 4.9 Common reasons silt fences tend to fail.



## TURBIDITY CURTAIN

A turbidity curtain is a flexible, floating barrier used to temporarily contain suspended sediment along a shoreline or within a waterbody during dredging, pile driving, bridge work, or other similar shoreline construction projects. A turbidity curtain has a flotation system at the top, a fabric skirt between the float and the bottom, and a weighted ballast or anchoring system at the bottom. Sediment that has entered a waterbody is blocked by the turbidity curtain from spreading by wind or currents further into the waterbody. Turbidity curtains are not intended to be the sole or primary sediment control practice. They also do not perform well in strong currents or wave action. Turbidity curtains should be considered the last line of perimeter defense and should be used in conjunction with upland ESC measures.

### Minimum Plan Requirements

Details of the turbidity curtain shall be shown on the plan and contain the following items:

- Type and size of turbidity curtain
- Location on site
- Method and location for anchoring the curtain
- Removal methodology

### Design

The type of turbidity curtain selected will depend on the application, depth, anchoring, and floatation and fabric preferences (**Figure 4.10**). There are three types of DOT certified curtains. Type 1 is for relatively lightweight use in calm waters or small ponds where wind, waves, and currents are minimal, and depths are shallow. Type 2 curtains are designed for use in moving water with mild current, wind, or wave action. Type 3 curtains are for open water applications with moderate wind, waves, and flow. Most manufacturers and suppliers offer design assistance based on the application, length of coverage and depth to bottom. **Table 4.5** summarizes fabric, floatation, tension and ballast, and standard dimensions for the three classes of turbidity curtains.

When ordering from a manufacturer, consider additional site-specific design elements such as tapering of skirt to conform to the bottom profile, anchor systems, furling lines and ropes, marker buoys, solar powered lights, and repair kits. Make sure the



*Example of the use of turbidity curtains in Smith Bay, St Thomas.*

end connections at floats and tension cables (if applicable) include lacing grommets on reinforced fabrics, chain end shackling between sections, and tool free connections.

### Installation

1. Follow installation procedures from the manufacturer.
2. Prior to installation, remove obstacles and debris from the area.
3. The turbidity curtain should be placed around the perimeter of your water or shore-based construction activity.
4. The curtain must be firmly anchored in place. Place shoreline anchor outside of areas to be disturbed by construction equipment. For shallow installations, curtain can be secured by staking rather than using floatation system.
5. Anchor curtain toe as needed depending on wave action and boat traffic.

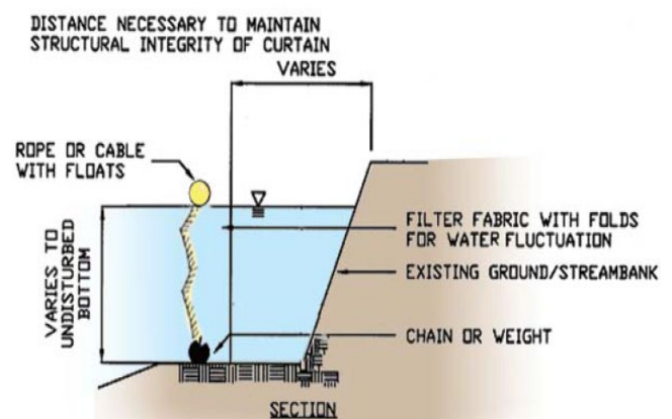

*Figure 4.10 Typical turbidity curtain with floatation and anchoring devices.*

Table 4.5 Specification summary for DOT-certified turbidity curtains

Type	Application	Fabric	Floatation	Chain/Cable	Section Length/ Skirt depth*
Type 1 silt curtains	Protected, calm waters where wind, waves, current, are minimal	18oz PVC-coated; (14 oz economy) Optional woven/nonwoven filter fabric for skirt	6"-8" expanded polystyrene foam in sealed float pockets (4" economy)	1/4" galvanized steel ballast chains (no cable); 5,200 lb breaking strength; 0.63 lb/ft weight; (3/16" economy)	25 ft, 50 ft, and 100 ft  Skirt depth to 20 ft
Type 2 turbidity curtains	in moving water with mild current, wind, and wave activity	22 oz PVC-coated (18 oz medium duty); Optional woven/nonwoven filter fabric for skirt	8"-12" based on skirt depth (6"-10" medium duty)	5/16" top tension cable (9,800 breaking strength); 5/16"- 3/8" galvanized steel bottom chain (7,600 breaking strength, 0.93 lb/ft weight)	50 and 100 ft standard  Skirt depth to 50 ft
Type 3 turbidity curtains	Open water exposed to moderate wind, waves and moving water	22 oz PVC-coated or more; stress plates at bottom skirt corners; Woven or non-woven skirt option	8"-24" (depending on skirt depth and level of duty)	Two 5/16" galvanized steel cables above and below float (9,800 lb breaking strength); 3/8" galvanized steel chain (10,600 lb breaking strength, 1.41 lb/ft weight)	50 and 100 ft standard  Skirt depth to 100 ft

\* Skirt depth should account for changing water levels due to tides, wave action, drawdowns, etc.

## Maintenance

- Inspect the turbidity curtain weekly, and check anchors and attachments after heavy winds or wave action.
- All floating debris should be removed to prevent damage to the floatation devices and skirt.
- Any problem or failure of the curtain must be repaired immediately so that the curtain will remain effective.
- If removal of sediment behind curtain is necessary or at the end of construction, remove by hand. Allow 24 hours for sediment to settle before removing the curtain from the water. Remove curtain by carefully pulling it towards shoreline to minimize the release of remaining sediment. All excavated sediment should be disposed of properly.

## Troubleshooting

- Ripped fabric should be repaired quickly to reduce additional damage. Order repair kit at time of purchase and make sure the skirt fabric includes reinforced corners and grommets at chain and cable connections.
- Anchors do not hold curtain in place. Add additional or heavier ballast chains at bottom and reattach anchors.
- Flow, wind, or wave action is greater than anticipated. Replace with higher duty product.



*Do not use silt fence in lieu of a turbidity curtain for in-water construction activities.*



*Anchor stakes hold curtain in place. Turbidity curtains are the last line of defense.*



## 4.2 STABILIZATION PRACTICES

Stabilization is the most effective approach to preventing erosion of disturbed areas. Even if a phased

clearing strategy is followed, exposed soils and unpaved roads can be left bare, untouched, and susceptible to erosion for months, if not years. Federal and territorial regulations require that bare areas left idle for more than 14 days must be temporarily stabilized. Temporary stabilization is covering exposed soils with materials that are expected be removed during final grading or when an area is ready to be worked. If work has been completed and brought to final grade, bare areas should be permanently stabilized. Permanent stabilization typically occurs at the end of the project, or in areas where no more work is anticipated. Roads and driveways must also be permanently stabilized with few exceptions.

There are various mechanical, vegetative, or structural methods for stabilization. For most sites, it will take a combination of practices to effectively prevent erosion:

- **Surface Roughening:** Mechanical stabilization that uses construction equipment to create temporary depressions, steps, and grooves on exposed slopes to slow and break up runoff.
- **Seeding/Planting:** Seed mixes uniformly applied by hand or hydroseed to an area to quickly establish temporary or permanent cover. Grass plugs or other plantings can also be used but may be less effective for rapid coverage.
- **Mulches:** Organic material uniformly applied to an area to quickly stabilize soils – could be used with or without seeding.



*This cut slope on a residential driveway in the BVI was stabilized with stone walls and landscape vegetation—a win/win for the homeowner and downstream coral reefs!*

- **Erosion Control Mats and Blankets:** A biodegradable or synthetic matting used to cover exposed area on slopes and in channels to prevent erosion and help establish vegetation.
- **Retaining Walls/Soil Bioengineering:** Structural features needed for stabilizing extreme steep slopes where other soil retention practices are not practical, particularly along road and building cuts.

**Table 4.6** provides a simple selection matrix for comparing the relative benefits of individual practices presented here. Contact DPNR for assistance in determining if other techniques not included here (paving, chemical binders, etc.) are acceptable.

**Warning!** *There are synthetic/chemical binders that can be used to bind and stabilize soil particles. These are not currently recommended in the VI until their effects on sensitive coral ecosystems has been further studied.*

*Table 4.6 Summary of stabilization practices and their relative benefits.*

Benefits	Surface Roughening	Seeding/Planting	Mulches	Erosion Control Blankets	Retaining Walls/Soil Bioengineering
Immediate Stabilization	●		●	●	●
Easy to Install	●	●	●	-	
Inexpensive		●			
Reduces Runoff	-	●			
Aesthetics		●			X
Good for Dry Season			●	●	●
Habitat		●			
Windbreak		●			
Low Maintenance			●	●	●

## SURFACE ROUGHENING

Surface roughening is a simple method to temporarily slow and minimize runoff by creating horizontal grooves, steps, or benches that run parallel to the contour of the land. Surface roughening should be done in conjunction with other stabilization activities to ease establishment of vegetation by seed, to reduce stormwater runoff velocity, increase infiltration, reduce erosion, and trap sediment.

### Minimum Plan Requirements

Surface roughening details shall be shown on the plan and contain the following items:

- Methodology
- Location(s) on site
- Frequency

### Design

Heavy equipment operators should use basic surface roughening techniques every day before leaving the site to slow and minimize runoff on erodible slopes. This technique can be used on all slopes, especially those steeper than 3:1 (33%). This is accomplished by creating horizontal grooves, depressions, or steps that run parallel to the contours of the land. There are three primary techniques to achieve surface roughening: tracking, stair-step grading, and grooving. These methods should be combined with other practices if an area is to remain idle for 14 days or more. Use with temporary seeding and temporary mulching to stabilize an area.

Selection of the appropriate method of surface roughening depends on the type of slope. The methods used include tracking, grooving and stair-stepping (**Figure 4.11**). Steepness, mowing requirements, and a cut or fill slope operation are all factors considered in determining roughening method.

**Stair-step grading or benching:** Cut steps or terraces into the slope parallel to the contours. The ratio of vertical cut to horizontal distance should not be steeper than 2:1. Maximum step width/height is 4 feet. The steps interrupt runoff flowing down the hill and slow the velocity to reduce erosion. Each step slopes back toward the hillside to collect sediment. This method works well with soils that contain many small rocks, to create benches for permanent planting or walls.



*Stair steps used to help establish grass to stabilizing a hillside (photo: Clemson University).*



*Large-scale benching and terracing prior to planting.*

**Grooving:** For slopes greater than 3:1 but less than 2:1. This involves using discs, tillers, spring harrows, or the teeth on the bucket of a front-end loader to create a series of small ridges and depressions parallel to the slope. Install grooves a minimum of 3 inches deep and a maximum of 15 inches apart.

**Cut and fill:** Techniques that can be applied to create a more stable slope or to establish a desirable 2:1 or flatter slope. This technique can be used to replace less stable soils with more adequate material or to incorporate stabilizing geotextiles during the process of regrading. Sometimes better soils are required to promote plant growth. Where fill is placed on a slope, the cutting of "V" notch contours into the existing ground can help improve slope stabilization by giving the fill material a footing into the native subgrade. The counterweight technique can be applied where space is available, which involves adding a level bench and gentle slope next to a steep failing bank to hold the bank up and prevent continued sliding. This makes for a good planting bench. Geosynthetics and structural anchors may be needed on steeper slopes.



*Cutting benches into an almost vertical slope to help support walls and plantings.*

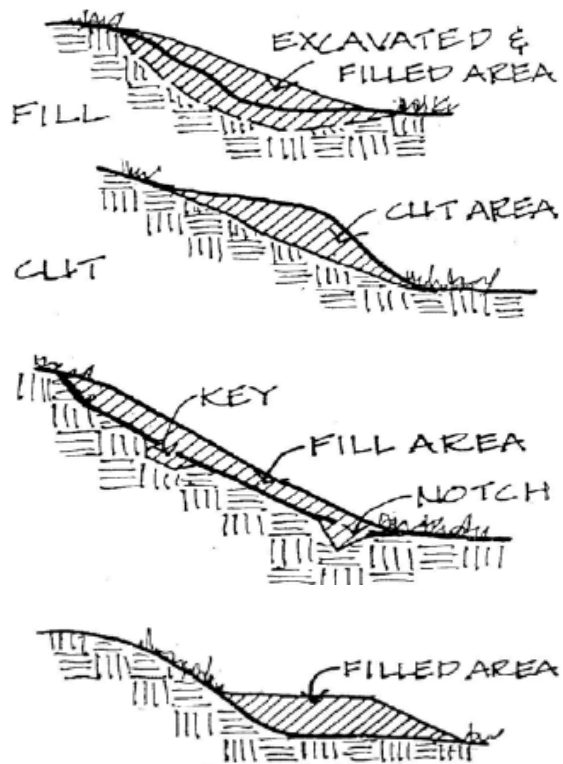
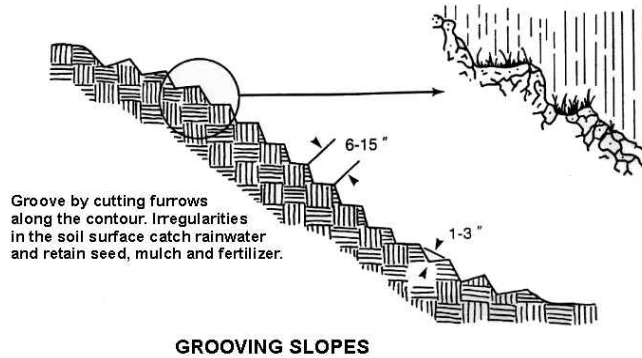
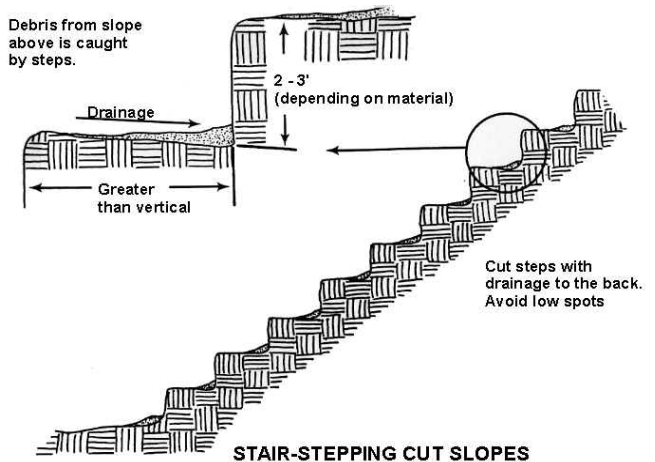

*Figure 4.11 (Left) Surface roughening details for stair-stepping and grooving (Empire State Chapter Soil & Water Conservation Society, 1991). (Right) Cut and fill, notching, and counterweight techniques (VT Better Back Roads).*

**Tracking:** involves driving a bulldozer up and down a slope, leaving cleat tracks *parallel* to the slope contour. This is the easiest but least effective of the surface roughening measures. Use tracking mainly in sandy soils to avoid compaction of the soil surface.

### Installation

1. Surface roughening should be performed immediately after initial clearing. Roughening can be done in combination with seeding and/or mulching for efficiency, particularly if construction on the slope will be inactive for 14 days or more.
2. Minimize the number of equipment passes to reduce soil compaction since this inhibits vegetation growth and increases runoff rates.
3. Determine roughening method based on steepness, mowing requirements, and a cut or fill slope operation:

#### Cut slope, no mowing

1. Stair-step grade or groove cut slopes with a gradient steeper than 3:1.
2. Use stair-step grading on any erodible material soft enough to be ripped with a bulldozer. Slopes of soft rock with some soil are particularly suited to stair-step grading.
3. Make the vertical cut distance less than the horizontal distance, and slightly pitch the step towards the vertical wall.
4. Do not make vertical cuts more than 2 feet in soft materials or 3 feet in rocky materials.

#### Fill slope, no mowing

1. Place fill to create slopes with a gradient steeper than 3:1 in lifts 9 inches or less and properly compacted. Ensure the face of the slope consists of loose, uncompacted fill 4 to 6 inches deep. Use grooving as described above to roughen the slope, if necessary.
2. Do not blade or scrape the final slope face.

#### Cuts/fills, mowed maintenance

1. Make mowed slopes no steeper than 3:1.
2. Roughen these areas to shallow grooves by normal tilling, disking, harrowing, or use of cultipacker-seeder. Make the final pass of such tillage equipment on the contour.
3. Make grooves at least 1 inch deep and a maximum of 10 inches apart.
4. Excessive roughness is undesirable where mowing is planned.



*Always roughen surfaces with tracking cleats running parallel to the slope contours (top) rather than perpendicular (bottom) (from Clemson University).*

### Maintenance

Because surface roughening is a temporary measure, the practice may need to be reapplied often, especially if frequent or heavy rainfall occurs. May need to reapply at the end of each day until other stabilization practices are installed. Inspect every 7 calendar days and within 24 hours after major rainfall event. As soon as rills appear on the surface, re-roughen and re-seed.

### Troubleshooting

- Tracking across slope instead of up-and-down it creates channels for flowing water. Change direction and drive up and down slope.
- Do not forget to re-grade as soon as rills appear, otherwise the eroding surface will quickly widen.
- Do not rely solely on mechanical stabilization to prevent erosion, deploy other techniques such as seeding or erosion control blankets.

## TEMPORARY SEEDING/PLANTING

Covering an area of bare ground with vegetation, topsoil, mulch, or erosion control blankets for temporary or permanent erosion prevention is critical. Temporary stabilization is often needed because grading operations can last several months and extend into or through the rainy season. Final or permanent stabilization will be required for project close out. Vegetative stabilization is the use of grass or other fast-growing plants to temporarily (or permanently) stabilize exposed soils and slopes. Vegetative cover can be established through a combination of seeding techniques, topsoil amendments, and mulching to conserve moisture and control weeds.

This practice is most effective in reducing erosion and sedimentation from disturbed areas, especially in areas where soils are unstable because of their slope, texture, structure, a high water table, or high winds. Once vegetation is established, its roots hold the soil in place and the vegetation also slows down runoff, increases infiltration, and filters out sediments. However, temporary seeding may not be effective in arid and semiarid regions (eastern portions of the islands) or during dry seasons (where/when climate prevents fast plant growth). In those areas, mulch and/or erosion control blankets may be more appropriate for the short term.

Temporary seeding should take place as soon as possible but **no later than 14 days** after the halt of construction activities on all disturbed areas that are likely to be re-disturbed, but not for several weeks or more. This includes denuded areas, cuts, fills, soil stockpiles, sides of sediment basins, and road banks.

Permanent vegetative stabilization once construction is complete is especially important on slopes, in filter strips, buffer areas, vegetated conveyances, and within aquatic buffers. The final planting plan should provide a gradual transition from the constructed areas to the preserved vegetation around or within the site, complementing and enhancing their aesthetic, habitat, windbreak, screening and other benefits. Special attention should be given to maintaining or improving habitat for rare, threatened or endangered species, where applicable. Contact the DPNR Division of Fish and Wildlife for information on Virgin Islands habitat requirements.



*Vetiver grass planted in tight rows can stabilize an exposed slope.*

### Minimum Plan Requirements

Seeding and landscape planting details shall be shown on the plan and contain the following items:

- Temporary seeding methodology including topsoil stockpiling instructions, seedbed preparation, soil amendments, seed mix, details on hand seeding or hydroseeding, application rates, and irrigation needs.
- Permanent planting/landscape plans including the square footage of seed mixes and groundcover, and the number of shrubs and trees proposed at the site.
- Complementary ESC practices as necessary such as surface roughening, mulches, and/or erosion control blankets.

### Design

Suitable soil, proper seedbed preparation, adequate water, suitable seed/plant species selection, and effective seeding/planting methodology are required for vegetative stabilization to be successful. Apart from not clearing native vegetation to begin with, vegetative stabilization is one of the most effective methods of preventing erosion.

1. **Topsoil:** On sites to be graded, strip and stockpile the topsoil. After grading is completed, spread the topsoil evenly over the area. On un-graded areas where the exposed soil is unsuitable for growing of vegetation, spread a 2- to 6-inch layer of good topsoil before planting. The topsoil should be fertile, free of litter, rocks, and objectionable weeds, and contain no toxic substances. A pH of 5.0 to 7.5 is most desirable, and soluble salts should not exceed 500 parts per million (ppm).

Ordinarily, a topsoil depth of 3 to 6 inches, after settling, is considered adequate for establishing grasses. Topsoiling is not necessary for temporary seeding, but it may improve chances for vegetation establishment. **Table 4.7** provides guidelines for the volume of topsoil required for application.

*Table 4.7 Volume of topsoil required for application to various depths (USDA-SCS, 1990b).*

Depth (inches)	Cubic yards per 1000 square feet	Cubic yards per acre
1	3.1	134
2	6.2	269
3	9.3	403
4	12.4	538
5	15.5	672
6	18.6	807

The surface grade should be at least 1 percent or more away from buildings. The grade and slope should permit the use of regular maintenance equipment. The best slopes for grass maintenance are 3:1 or flatter. Steep, vegetated slopes may also require structural stabilization, such as retaining walls or bench terraces.

2. **Seedbed Preparation:** Scarify with rake or tiller if compacted by heavy equipment. Remove all debris, such as rocks, stumps, scrap lumber, mortar or concrete, and rocks. If possible, disturb these areas as little as possible, especially on very steep slopes. After applying topsoil, if required, loosen the soil to a depth of several inches. Perform all tillage operations across the slope to reduce erosion hazard. Seed bed preparation may also require fertilizer application to make conditions more favorable to plant growth. Proper fertilizer application, seeding mixtures and seeding rates vary depending on soil type, slope, and weather.
3. **Seeding:** Broadcast seeding can be done either mechanically or by hand. It is very important to select appropriate grass species and to time seed. Seeding native or naturalized grass species will increase the odds for success in establishing vegetation. Native species also tend to have lower maintenance needs because they are adapted to the environmental conditions in the area. Grasses and legumes are the most common types of plants used for stabilizing slopes. Annual grasses such as

rye or fescue can be used to provide temporary cover. Common bermuda or bahia grass (perennials) can also be added to the seed mix to provide temporary stabilization on bare soils that will be disturbed again before construction is complete, but not for a considerable amount of time. Plant grasses during the rainy season and according to manufacturer's specifications.

See **Table 4.8** and **Table 4.9** for information on lawn grasses appropriate for use in the Virgin Islands, their propagation methods, and preferred conditions for establishment. Common bermuda grass seems to be one of the easiest to establish. It may be necessary to increase the seed rate to account for loss to birds and pests. Do NOT allow livestock to graze the grass. Also do not allow equipment to travel over the newly vegetated area to the point that the practice is destroyed.

### *Hydroseeding*

For large applications, seed is often applied with hydroseeding equipment that uses water spray for distribution. Hydroseeding equipment is used to uniformly apply a combination of seed, a mulch product (e.g., usually paper based) to hold soil moisture, a tackifier to glue seed and mulch to the surface, and in some cases, a fertilizer to help promote plant growth. These materials are mixed with water in a hydroseeder tank and sprayed out over the disturbed soil area. The mulch is typically colored with green dye as a visible indicator of the extent and thickness of the application. Hydroseeding allows rapid stabilization of a site with a minimum amount of labor. Application rates for hydroseed are as follows:

Seed mix: The amount of seed required for the targeted coverage is provided by the manufacturer. If unavailable use the following guideline and modify, as needed:

- 50 gallon = 4 pounds
- 100 gallon = 8 pounds
- 150 gallon = 12 pounds
- 300 gallon (1/8 acre) = 25 pounds
- 500 gallon = 40 pounds
- 750 gallon (1/4 acre) = 75 pounds

Pre-germinated seed may be used in the system. Several methods of pre-germinating seeds exist. An easy-to-use system is to soak the seed in a container of clear water over night, the night before use. A



garbage can or drum is ideal. Fill the container about 2/3 full of seed, then add water. By morning the seed would have swelled, and the container will be full. The seed can then be dumped in the hydroseeder tank as needed. Pre-germinated grass seed will normally germinate in about half the normal time. Grass seed will only germinate at certain temperatures and pre-germinated seeds are less sensitive to ground temperature. For faster germination, seeds may be soaked for 24 hours (4 hours in water, followed by 4 hours out, etc.).

**Mulch:** Cellulose mulch made from chopped up newspaper, with a green coloring agent, and anti-foaming agents is recommended for general use in the hydroseeder. Mulch usually comes in 50-pound bales. The recommended amounts for use are:

- 50 gallon = ¼ bale (12.5 lbs.)
- 100 gallon = ½ bale (25 lbs.)
- 150 gallon = ¾ bale (37.5 lbs.)
- 300 gallon = 1 ½ bales (75 lbs.)
- 500 gallon = 2 ½ bales (125 lbs.)
- 750 gallon = 3 ½ - 4 bales (175 - 200 lbs.)

These amounts are not necessarily the maximum. Ideally, the seed, mulch & water slurry should have about the consistency of apple sauce. If the spray has very little coloring, the mulch is too thin. If the spray has very little power, the mulch is too thick. Break up the mulch as much as possible as it is added to the tank. Clumps can be pulled through the hydroseeder before it has a chance to break them up, causing clogging problems.

**Fertilizer:** Most products intended for lawn applications can be used, including granular types. For new seeding, a starter fertilizer may be needed. Starter fertilizers are generally high in phosphorus (the middle number on a fertilizer bag, such as 5-10-5). Phosphorus will stimulate grass root growth. Use the fertilizer amount recommended by the manufacturer for the desired coverage. High nitrogen fertilizers are not recommended for seeding.

**Tackifier:** An optional ingredient in the hydroseeding mix, tackifier is a blend of gelling, hardening, and loading agents designed to hold seed in place. Tackifier is used in adverse weather or on steep slopes. Some tackifiers also lubricate the hydroseeder and reduce clogging. Most mulch manufacturers also manufacture tackifier. Start with a lower than suggested amount of tackifier and work up to avoid possible clogging. If a build up at the top of the tank is observed, reduce the application rate. Tackifier should not be added to the tank until right before spraying. In some instances, tackifier can already be mixed in with the mulch.

**Lime:** Lime is not recommended for use in a hydroseeder. There are liquid products available that alter pH and have the same results as lime.

4. **Slope Applications:** On slopes steeper than 4:1 or in sandy, clayey or caliche soils, seeding should be combined with at least one other erosion control method such as erosion control blanket, mulch, or stair-stepping to provide protection from rainfall



Hydroseeding at Green Cay, STX. Hydroseed mix includes seed, mulch, tackifier, and sometimes fertilizer (source: Protectores de Cuencas).

and wind and to prevent birds from eating the seed. Seeded areas should also be mulched and matted if the weather is excessively dry or if heavy rain is expected before the seed germinates.

5. **Plant Selection:** When naturalizing slopes with vegetation, use native species and consider root structure (e.g., woody plants & vetiver with extensive roots to hold soils). Many low-maintenance, native plants can be added to the site's seeding. Some good native plants available in local nurseries include wild frangipani, orange man jack, pink cedar, sea grape, lignum vitae, turpentine tree, teyer palm, sabal palm, wild ferns, wild anthurium, and spider lily.

If exotic plants are incorporated into the landscape, be careful to choose species that won't escape into natural areas and crowd out native plants. Vetiver grass (*Vetiveria zizanioides*) hedges can be planted across slopes (along the contour) to form a living terrace. Vetiver is a non-native, non-invasive, clumping grass species used in Africa, India and Southeast Asia to stabilize slopes and channels by trapping sediment behind the grass (see more on Vetiver below). Some exotic ornamental plant species often used around the home include hibiscus, bougainvillea, oleander, croton, heliconia, ginger, isora, aralia, agave, and non-native palms. Fruit trees and vegetable gardens can also be planted once construction is completed.

## Installation

Before extensive grading begins, remove and stockpile topsoil from excavated areas for later use. To prepare an area for seeding:

1. Remove surface debris such as cobbles, dirt clods, roots, and tree branches.
2. Combine with surface grading techniques on steep slopes such as terracing or bank benches to break slope and provide planting shelves.
3. Lightly compact all fill material and roughen surface at least 12 inches deep in the area to be seeded.
4. Have your soil tested to determine its pH and nutrient content.
5. Apply seeds uniformly by hand, cyclone seeder, drill cultipacker seeder, or hydroseeder. If seeding



*Hydroseeding can be used very cost-effectively for temporary or permanent stabilization of steep slopes (top) and flat terrain (from Protectores de Cuencas). Vetiver plugs and pipe slope drains can be used in combination with hydroseeding to improve stabilization success (bottom).*

on steep (>15%) slopes or during the rainy season, protect the seed and soil with erosion control blankets.

6. For hydroseeding, make sure slurry is uniformly applied at the appropriate mix and application rate. Grasses vary dramatically in tolerance for drought, shade, and nutrient requirement. Slurry should be generously applied and should not be runny. For slopes, start applications at the top of slopes and work your way down. Spray from more than one direction to ensure full coverage of surface. Let dry and inspect coverage.
7. Temporary stabilization is required for any area left untouched for 14 days or more.
8. Establish permanent stabilization by seeding or planting as soon as construction is final and the soil/seedbed is prepared.

9. Plugs are typically planted 12-inches on center but follow the nursery recommendations.
10. Successful stabilization with seed means that you have at least 70% coverage of grass to bare soil in a given location (see **Figure 4.12**).

**Warning!** You'll need 70% coverage of vegetation to bare soil in a localized spot to consider the area to be successfully stabilized.

### Maintenance

Proper maintenance of seeding and planting practices will ensure erosion protection and improve the appearance of the site. Plan maintenance activities as preventative treatment to avoid serious problems in the future. Frequent inspections are necessary to ensure that the grass/plants are growing properly.

Common vegetation maintenance activities include:

- Reapply seed, mulch, or topsoil as needed to provide uniform stabilization. Regular attention to small areas will save on future large costs. Be sure to include a line item for re-seeding in construction contract.
- Irrigate as necessary to establish grass/plants.
- Maintain other ESC practices to protect area until vegetation is fully established.
- Apply erosion control blankets if needed to protect the surface and aid plant establishment.
- Mow grassed areas frequently to control weeds and unwanted woody vegetation. Mowing height should be minimum of 3 inches (height should be higher during the dry season and times of drought). Pay special attention to herbaceous vegetation in outlets and waterways and turf areas such as lawns and playgrounds.
- New vegetation may need fertilization the first 2 or 3 years after establishment to maintain density and improve vigor. Fertilize according to soil test recommendations.
- Use herbicides for invasive species management, as directed by manufacturer, and according to Territorial and Federal regulations (contact DPNR or UVI Cooperative Extension Service for herbicide information).

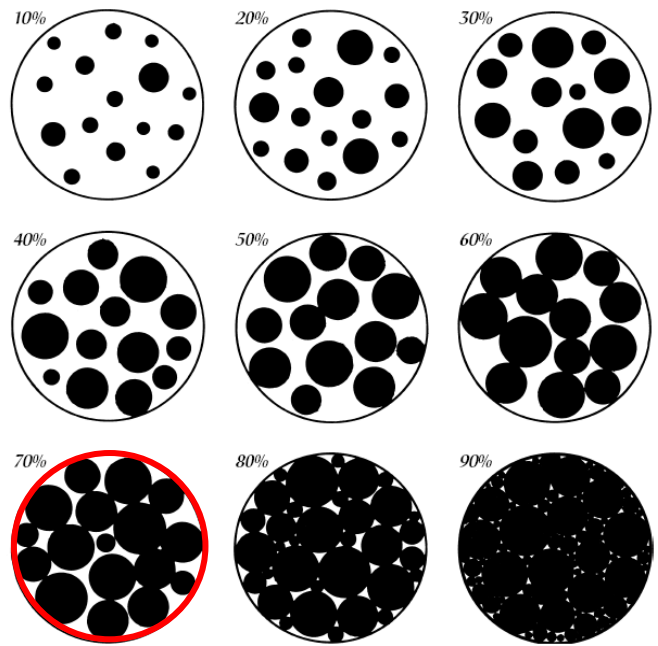

Figure 4.12 For successful stabilization, you need at least 70% plant to bare soil coverage ratio in a fixed location, as illustrated here where black dots represent grass and white space indicates bare soil (Cornell University).



Cordia being planted through jute erosion control blanket on a slope on St. Croix's east end. Consider irrigation needs for plant establishment.

## Troubleshooting

- Hydroseed application too thin. Reapply.
- Vegetation sparse and inconsistent. Make sure soil is suitable to support establishment and re-seed. Be sure to maintain adequate soil moisture through watering and/or increased mulch ratio.
- Vegetation never becomes established at all. Ensure tackifier is applied thoroughly with mulch so that it doesn't blow away. Ensure soil isn't too compacted.
- Rills are forming on the surface before vegetation can be established. Install erosion control blankets and redirect runoff with piped-slope drains

## More on Vetiver

Vetiver is a perennial bunch grass with a massive root system (2 ft on each side of the plant and >8 ft deep) that is great for stabilizing slopes, phytoremediation of heavy metals and PAHs in the soil, as well as wastewater treatment.

It grows on a wide variety of soils from sands to clay with a pH range from 4 to 7.5, prefers neutral to slightly alkaline soils, and tolerates saline soils.

1. Use only sterile genotypes, such as "Sierra" varieties in the Caribbean region.
2. Harvest and divide clumps with shovel or pickaxe, keeping as much of root as possible. Prune to 10-20 in. Store in fresh, humid location until planting.
3. Mark contour lines in the field and dig furrow. Plant clumps an equal distance from each other 4-6 inches apart. DO NOT LEAVE OPEN SPACES, which might allow gullies to form. Plant a double row if high water flows anticipated (**Figure 4.13**).
4. Once established, monitor the barrier and replant vetiver if needed. Keep it pruned to about 20 inches tall to encourage root growth.

See NRCS (2015) fact sheet: *Control Soil Erosion, Maintain and Improve Water Quality with Vetiver Barriers* and the CBCC (2017) guide on *Vegetation for Erosion Control* for more details.

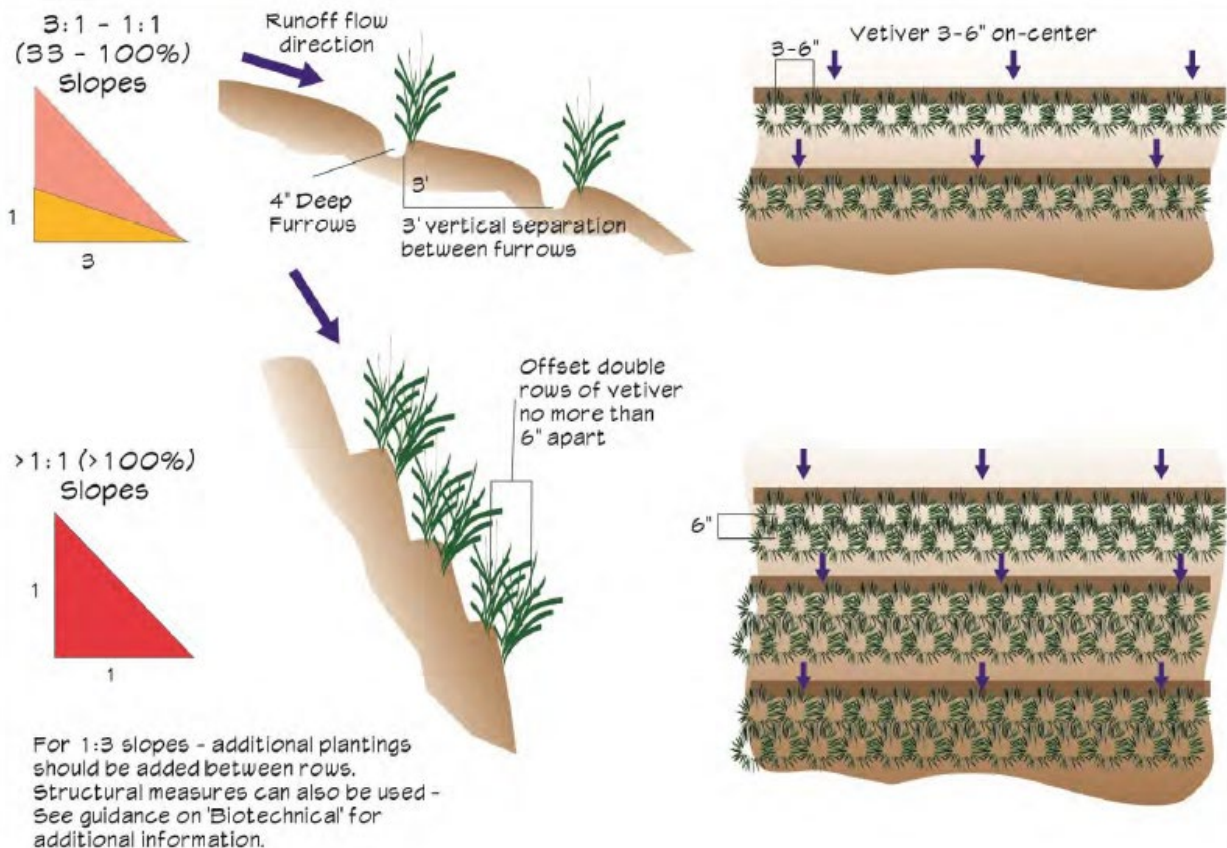

Figure 4.13 Example details from Coral Bay Community Council (2017) provides guidance on vetiver installation techniques for different slopes. For slopes flatter than 33%, vertical spacing between rows can increase to 6".

Table 4.8 Suitable grass species for seeding and planting in the Caribbean (USDA- SCS, 1990b).

Plant Species	Propagation	Adaptation
<b>Carpetgrass</b>	8 lbs. per acre	Wet and shaded areas
<b>Common bermuda grass</b>	80 lbs. per acre	Throughout the island
<b>Guinea grass</b>	30 pounds per acre or vegetative	Dry areas & alkaline soils; shady areas; Intolerant to wet and acid soils
<b>Paragrass</b>	Vegetative	Throughout the island, especially wetlands and other wet areas
<b>Pangolagrass</b>	Vegetative	Throughout islands, except dry areas
<b>Vetiver</b>	Vegetative	Especially adapted to granitic soils
<b>Angleton grass</b>	Natural seeding	All dry sites
<b>Buffel grass</b>	4 lbs. per acre	All dry sites
<b>Beach Grass (<i>Sporobolus virginicus</i>)</b>	Vegetative	Especially Adapted to Saline Sites

Table 4.9 A tabular comparison of lawn grasses (USDA-SCS, 1990b).

Grass	Texture	Maintenance		Soil Type	Tolerance to:		Resistance to:		Establishment		Mow Type	Mowing Height (in)	Insect Problems	Disease Problems
		Mowing	Fertilizer (per year)		Shade	Salt	Drought	Wear	Method	Rate				
<b>St. Augustine grass</b>	medium to coarse	weekly	3 to 4	alkaline	good	good	poor	good	vegetative	medium to fast	reel or rotary	1½ - 2½	Chinch bugs Armyworms Mole-crickets	Brown patch Grey leafspot
<b>Centipede grass</b>	medium	bimonthly	1	acid	fair	poor	good	poor	vegetative	medium	reel or rotary	1¼ - 2	Ground pearls Armyworms Spittle bugs Mole-crickets	Brown patch
<b>Zoysia grass</b>	fine to medium	weekly to bimonthly	3 to 4	wide range	good	good	good	good	vegetative	slow	reel	½ - 1¼	Armyworms Billbugs Mole-crickets	Brown patch Dollar spot
<b>Improved bermuda grass</b>	fine	1-3/week	4 to 12	wide range	very poor	fair	poor	good	vegetative	very fast	reel	½ - 1	Armyworms Scale insects Mole-crickets	Dollar spot Brown patch Helminthosp orium
<b>Seeded bermuda grass</b>	medium fine	1-2/week	4 to 12	wide range	very poor	fair	fair	good	seed or vegetative	very fast	reel or rotary	½ - 1	Armyworms Scale insects Mole-crickets	Dollar spot Brown patch Helminthosp orium
<b>Bahia grass</b>	medium to coarse	weekly	1 to 2	acid	fair to good	poor	fair	good	seed or vegetative	medium	rotary	2½ - 3	Armyworms Mole-crickets	Brown patch
<b>Carpet grass</b>	medium	weekly	1	wet, poorly drained, acid	good	poor	very poor	fair	seed or vegetative	medium	rotary	1¼ - 2	Armyworms Mole-crickets	Brown patch

## MULCHING

Mulching is a temporary soil stabilization or erosion control practice. Mulch is a loose material, such as wood chips or other ground up organic debris, placed on the surface of exposed soils to prevent erosion for short periods until vegetation is established or construction is completed. Mulches protect the soil from the impact of falling rain, slow the velocity of runoff, and increase the capacity of the soil to absorb water. When used together with seeding and planting, mulching can aid in plant establishment by holding seed, fertilizer, and topsoil in place; by helping to retain moisture; by insulating against high temperature, and by protecting seed from birds. Mulching of cleared material on site can be a cost-effective erosion control method; however, be careful not to spread tan tan or other invasive seed. Also, please note that invasive insects love mulch, so if you are bringing in mulch from off island, make sure it has been treated.

### Minimum Plan Requirements

Details of mulching shall be shown on the plan, including:

- Type and size of mulch
- Area to be mulched and mulching rate
- Removal method if needed for temporary applications

### Design

- Loose mulch should only be used on fairly level slopes (<10%) with soils that are not highly erodible, or in areas that only need short-term stabilization.
- Mulch rates range from 7 to 25 tons per acre depending on slope.

### Installation

- Mulch can be used to stabilize bare areas that will be untouched for more than 14 days. Before clearing a site, determine if you are going to mulch organic debris on site to be used for temporary stabilization, so the material is not unintentionally removed.
- Preserve existing topsoil in place where possible if area will be seeded/planted.
- For areas that won't be planted, stockpile topsoil from excavated areas for later use.



*Mulched site material can be spread to temporarily stabilize low slope surfaces.*



*Mulching on site as clearing occurs is standard practice; however, clearing only the area needed for construction (site fingerprinting) and leaving as much natural vegetation in place as possible, is the preferred approach.*

### Maintenance

Mulched areas should be inspected frequently. Where mulch has been loosened, shifted, or washed away, replace mulch immediately.

### Common Problems

- Mulch continually washes away, allowing erosion of exposed soil. Consider other more effective stabilization practices for that area.

## EROSION CONTROL BLANKETS

Temporary erosion control blankets (ECBs) are rolled products made from natural or synthetic fibers (e.g., straw, jute, coir, polypropylene) that have been woven into a single or multi-layered matting or netting. They are used to stabilize soils while grasses or ground covers become established. ECBs offer a more stable alternative for slopes and channels because they can withstand higher stormwater velocities. ECBs are designed for immediate to long-term erosion protection and vegetation establishment depending on weather, soil type, slope, design hydraulics, and the duration of the project.

Light duty applications may only need single mesh or straw-filled biodegradable matting. Heavier duty applications may require multi-layer matting with non-degrading polypropylene netting called turf reinforcement mats (TRMs). Some ECBs are appropriate for permanent vegetation reinforcement. There are many types of biodegradable or synthetic products available for different applications. ECBs do not offer significant moisture retention or temperature moderation benefits.

### Minimum Plan Requirements

Details of the ECB shall be shown on the plan and contain the following items:

- Type of ECB
- Type and size of staples or stakes for anchoring
- Installation method and sequencing related to seeding
- Removal method if needed for temporary applications

### Design

Erosion control blankets come in rolls. The type of ECB to be used on a site depends on the purpose of the mat (e.g., permanent turf reinforcement mat, 100% biodegradable blanket, extended or long-term degradable mat, or short-term photodegradable mat) and the location of installation (slope or channel). Some ECBs incorporate coconut fibers and/or long lasting, UV stabilized netting to provide a higher degree of erosion protection, durability and longevity than single and double net short-term products.

ECB selection (straw, jute, synthetic, or some combination) depends on the steepness of the slope,



*(Top) Installation of straw filled ECB lengthwise down a side slope. (Bottom) Example of a stabilized and unstabilized slope. Lower slope has erosion control blankets with green plastic mesh to protect steep slopes while vegetation becomes established. Think carefully about using plastic as it is not ideal for animals and is relatively permanent.*

the velocity of water to be flowing over the mat, and the intended duration of the installation. For example, 100% straw mats can be used on slopes up to 3:1 in steepness and 75 feet in length or in low-flow swales. Straw/ jute mats can be used on steeper slopes (2:1 – 1:1, depending on length) and medium flow discharge channels. Jute fiber or synthetic mats provide long-term protection on steeper slopes or in high discharge channels. Check the manufacturer's specifications to determine which material is appropriate for a given application. **Table 4.10** provides an example selection matrix for ECBs.

ECBs are typically secured with 6" metal staples or wood stakes, depending on the conditions. Anchors greater than 6" may be necessary to properly secure the ECBs.

## Installation

Installation specifications vary by manufacturer and usage, whether for slope or channel installations. When installing ECBs in channels, a different layout and anchoring procedure is required. Refer to installation instructions under Lined Waterways in the section on Diversions and Conveyance.

For *slope installations*, install and secure blanket according to manufacturer's instructions, generally following this procedure (**Figure 4.14**).

1. Divert runoff away from the application area as possible.
2. Remove tree stumps, rocks and debris to prepare a smooth surface.
3. Grade and lightly compact area prior to installation.
4. For areas that will be seeded, prepare the seed bed, apply seed and fertilize if needed before applying ECB.
5. Dig 6 x 6-inch anchor trench along top of slope.
6. Lay edge of blanket 6-12 inches beyond top edge of trench. Using staples or stakes approximately 12" apart, fasten blanket into bottom of trench; backfill with soil and compact. Cover backfill with remaining edge of blanket and fasten on downhill side of trench.
7. Unroll ECB down slope, ensuring direct contact with the ground surface; overlap edges a minimum of 3 inches.
8. Fasten with staples or stakes per manufacturer's instructions. Never pull or stretch the blanket.
9. Consecutive mats spliced down the slope must be placed end over end (shingle style) with an approximate 3" - 6" overlap. Staple through overlapped area, approximately 12" apart across entire mat width.
10. On extremely arid sites where grasses cannot survive, native ground covers or shrubs can be planted in jute or coir (coconut fiber) netting.
11. If using ECBs over seed or hydroseed, be sure to amend top few inches of soil (if needed) and apply seed to area.

## Maintenance

When installed properly, ECBs rarely need substantial maintenance.

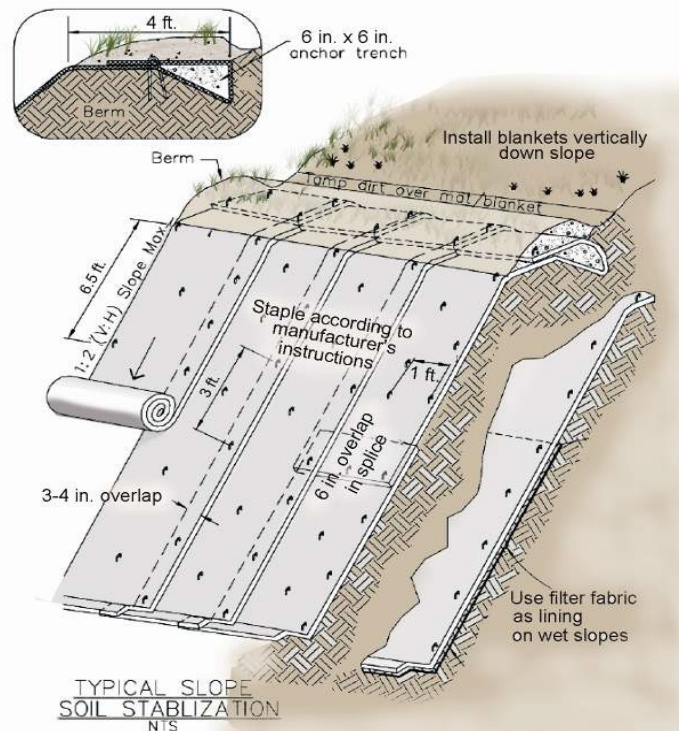

*Figure 4.14 When erosion control blankets are installed properly, they require very little maintenance.*

- Regular inspections should be made to identify cracks or tears in ECBs, which should be repaired or replaced immediately. Synthetics may degrade in sunlight. Inspect the surface for any tears in the fabric or downward slippage.
- Effective netting and matting require firm and continuous contact with the soil. If there is no contact, the material will not hold the soil in place and erosion will occur underneath it. Re-anchor the fabric at the top of the slope if it loses contact with the soil or any part of the slope becomes exposed. Try to avoid stretching the material when moving it around.
- When left in place for a long time, synthetic fabrics may experience ultraviolet degradation, and natural fibers may begin to decay. In this case, if vegetation has not fully established, replacement may be required to maintain stability of the slope and prevent erosion.



## Troubleshooting

- Poor ground contact prevents plant growth or erosion occurring beneath ECB. Make sure material is in contact with the ground. You may need to remove, clear clumps and debris from surface, then reinstall. If no erosion evident, cut around base of plant and staple around cut edges.
- Blanket slipping down the slope. Check if it is properly trenched at top and along the seams. Re-anchor at the top of slope using manufacturer’s staples/stakes and stapling pattern.
- Matrix washing out of netting due to greater slope or hydraulic load than material can handle. Upgrade and replace ECB, enhance vegetative stabilization efforts, and/or install pipe slope drain or other measures to reduce flows down slope.



*The contractor at this jobsite on St. Croix failed to prepare the slope (note the lumps) prior to installation, properly trench ECB at top of slope, or secure blankets with stakes or staples along seams. Improper installation led to sloughing of blanket and localized erosion, and ultimately hindered hydroseeding success and plant establishment.*

Table 4.10 Example selection chart for erosion control products (adapted from Texas Erosion Supply)

Type	Net Description	Matrix Material	Longevity (months)	Typical Slope Application (H:V)	Channel Application Thresholds
Short-term temporary ECBs	Lightweight, photodegradable, synthetic top or top and bottom net	Straw	≤ 12	3:1 to 2.5:1	≤ 1.6 psf /5.0 fps to ≤ 1.8 psf /6.0 fps
	All natural, woven biodegradable jute top net or top and bottom net	Straw	≤ 12	3:1 to 2.5:1	≤ 1.6 psf /5.0 fps to ≤ 1.8 psf /6.0 fps
Extended term Temporary ECBs	UV-extended synthetic photo-degradable top net, lightweight or standard photodegradable, synthetic bottom net	Coconut/straw mix or all coconut fibers	≤ 24 to ≤36	2:1 to 1:1	≤ 2.0 psf /7.0 fps to ≤ 2.3 psf /8.0 fps
	Woven biodegradable jute top net or top and bottom net	Coconut/straw mix or all coconut fibers	≤ 24 to ≤36	2:1 to 1:1	≤ 2.0 psf /7.0 fps to ≤ 2.8 psf /9.0 fps
Permanent TRMs	UV-stable, permanent synthetic top and bottom net (8-12 oz + heavy duty)	UV synthetic fiber	≥36 to permanent	1:1 and greater	≤ 8 psf /12 fps to ≤12 psf /20 fps

## RETAINING WALLS/SOIL BIOENGINEERING

Structural retaining walls, geogrids and reinforced earth, and bioengineering practices can be used for slope stabilization.

### Structural Soil Retaining Walls

Used to hold loose or unstable soil firmly in place, these hard structures are made of stone or concrete blocks. Soil tie backs and retaining walls can be used during excavation to prevent cave-ins and accidents, but when designed and constructed correctly, they also are excellent permanent erosion control practices that retain soils and slopes to prevent movement. There are many different types of soil retaining structures:

- *Skeleton sheeting* is the least expensive soil retaining system. It requires the soil to be cohesive (like clay). Construction grade lumber is used to brace the excavated face of the slope. This is a temporary practice.
- *Continuous sheeting* uses a material such as steel, concrete or wood to cover the face of the slope in a continuous manner. Struts and boards are placed along the slope to provide continuous support to the slope face.
- *Permanent retaining walls* may be necessary to provide support to the slope after construction is completed. Concrete, stone, or wood retaining walls are generally permanent.

### Minimum Plan Requirements

Details of the retaining wall shall be shown on the plan and contain the following items:

- Type of retaining wall
- Calculations and stamp from licensed structural engineer, as necessary
- Installation method and sequencing
- Removal method for temporary applications

### Design

Retaining walls should only be used where other methods of soil retention are not practical. They are commonly used in the Virgin Islands for cut slopes along road and driveways and building sites. Soil retaining walls are used for both erosion control and safety purposes. Retaining wall design must address foundation bearing capacity, sliding, overturning,



*Living walls and bioengineered systems combine structural elements with plants for enhanced slope protection and long-term aesthetics (Gardendrum.com).*

drainage, and loading systems. These are complex systems, and all but the smallest retaining walls (<4 feet high) should be designed by a licensed structural engineer.

### Geogrids and Reinforced Earth

As an alternative to stone or concrete retaining walls, extremely durable geosynthetics with high tensile strengths may be ideal for stabilization on slopes steeper than 2:1 (**Figure 4.15**). They can resist degradation by water and chemicals normally found in soils and be planted over with vegetation for additional strength and aesthetics. Check with product manufacturer for specific installation details.

### Soil Bioengineering

A combination of mechanical, biological, and ecological concepts to stop and prevent shallow slope failures (or landslides) and erosion. Soil bioengineering techniques are generally appropriate for the immediate protection of slopes against surface erosion and shallow mass wasting (landslides), and provide cut and fill slope stabilization, earth embankment protection, and small gully repair treatment.

Soil bioengineering is often a useful alternative for small, highly sensitive, or steep sites where the use of machinery is not feasible and hand labor is a necessity. Existing vegetation should be retained whenever possible to provide protection against surface erosion and shallow slope failures. This vegetation can also be a source of cuttings to use in the practice. Native plant species that root easily

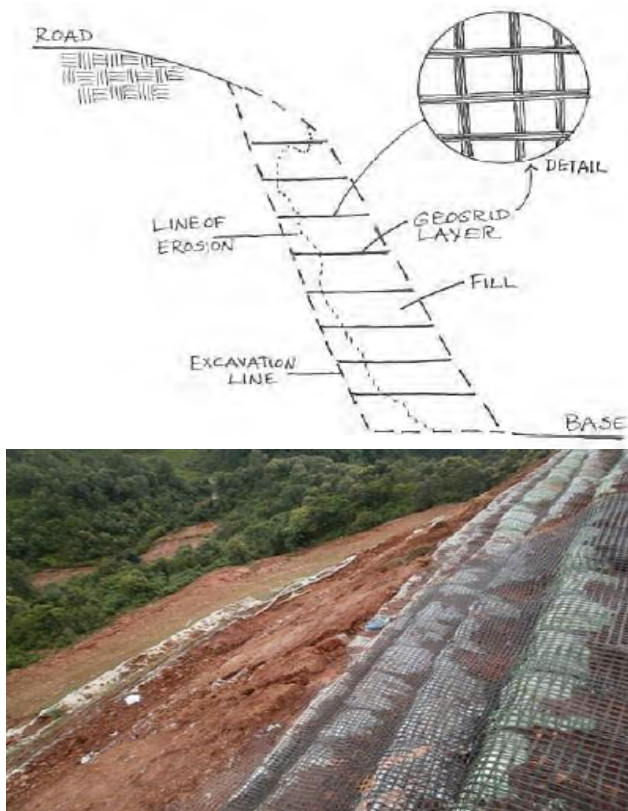

Figure 4.15 Geogrids layers stacked with fill to stabilize a slope (detail from VT Better Backroads Manual).

should be used (e.g., turpentine tree (*Bursera simaruba*), white manjack (*Cordia sulcata*), hog plum (*Spondias mombin*), orchids, bromeliads, anthuriums). Refer to the CBCC (2017) Vegetation Guide, or contact NRCS for more information on appropriate plants.

There are several different soil bioengineering practices that can be applied on a construction site or road cut depending on purpose and site constraints, such as slope, soils, geology, hydrology, vegetation available, and microclimate. Common techniques applicable to the VI are shown in **Figure 4.16** and **Figure 4.17** and described briefly below.

These techniques are used when vegetative stabilization alone is not feasible or effective. Their use may be limited on rocky slopes that lack sufficient soil or moisture to support plant growth unless amended with topsoil. Soil-restrictive layers, such as hardpans, may also prevent root growth. Consult the USDA-NRCS for further information on soil bioengineering practices.

- **Brush layering/live staking** is the placing of live branch cuttings in small benches excavated into the slope perpendicular to the slope contour. These benches can range from 2 to 3 feet wide and breaking up the slope length into a series of shorter runs. Brushlayer branches reinforce the soil with the unrooted branch stems and as roots develop, adding resistance to sliding or shear displacement. They provide slope stability and allow vegetative cover to become established. Vegetations aids in infiltration on arid sites, helps dry excessively wet areas, and may contribute to microclimate adjustments—thus, supporting germination and natural regeneration. The portions of the brush that protrude from the slope face help to slow runoff, trap debris, and reduce surface erosion. This redirects and mitigates adverse slope seepage by acting as horizontal drains.
- **Live Gully Repair:** Using alternating layers of live branch cuttings and compacted soil to repair small gullies. Installed branches provide immediate reinforcement to the compacted soil and reduce the velocity of concentrated stormwater flows. They also provide a filter barrier to reduce rill and gully erosion.
- **Vegetated Rock Gabions:** Rectangular baskets made of heavily galvanized steel wire that is triple-twisted into a hexagonal mesh. Empty gabions are placed in position, wired to adjoining gabions, filled with stones, and then folded shut and wired at the ends and sides. Gabions can be combined with woody and non-woody vegetation for aesthetics and stabilization. Live branches placed between the rock-filled baskets will root inside and in the soil behind the structures consolidating the structure and binding it to the slope.
- **Vegetated Rock Wall:** A combination of rock and live branch cuttings that is used to stabilize and protect the toe of steep slopes. Vegetated rock walls differ from conventional retaining walls in that they are placed against relatively undisturbed earth and are not intended to resist large lateral earth pressures.
- **Low Wall with Non-Reinforcing Plantings:** Low walls or revetments at the foot of a slope that have plantings on the interposed benches, crest of the wall, and the wall face. These systems are

NOT soil bioengineering structures because the plant materials represent little or no reinforcement value to the structure. Several basic types of retaining structures can be used as low walls. The simplest type is a gravity wall that resists lateral earth pressures with its weight or mass (e.g., Masonry and concrete walls, Crib and bin walls, Cantilever and counterfort walls, and reinforced earth and geogrid walls). Each of these can be modified a number of ways to fit almost any condition or requirement. Figure 4.17 depicts a low wall with vegetated slope.



Tiered wall/bench plantings in the VI (from Donna Somboonlakana)

- Tiered Wall/Bench Plantings:** A tiered retaining wall system where shrubs and trees are planted on the benches to screen the structure behind and lend a more natural appearance. For tiered structures, the roots of woody plants grow into the soil and backfill within the structure to bind them together. Arguably, massive vetiver roots systems may also permeate and protect tiered bench as well. Almost any type of retaining structure can be used in a tiered wall system.

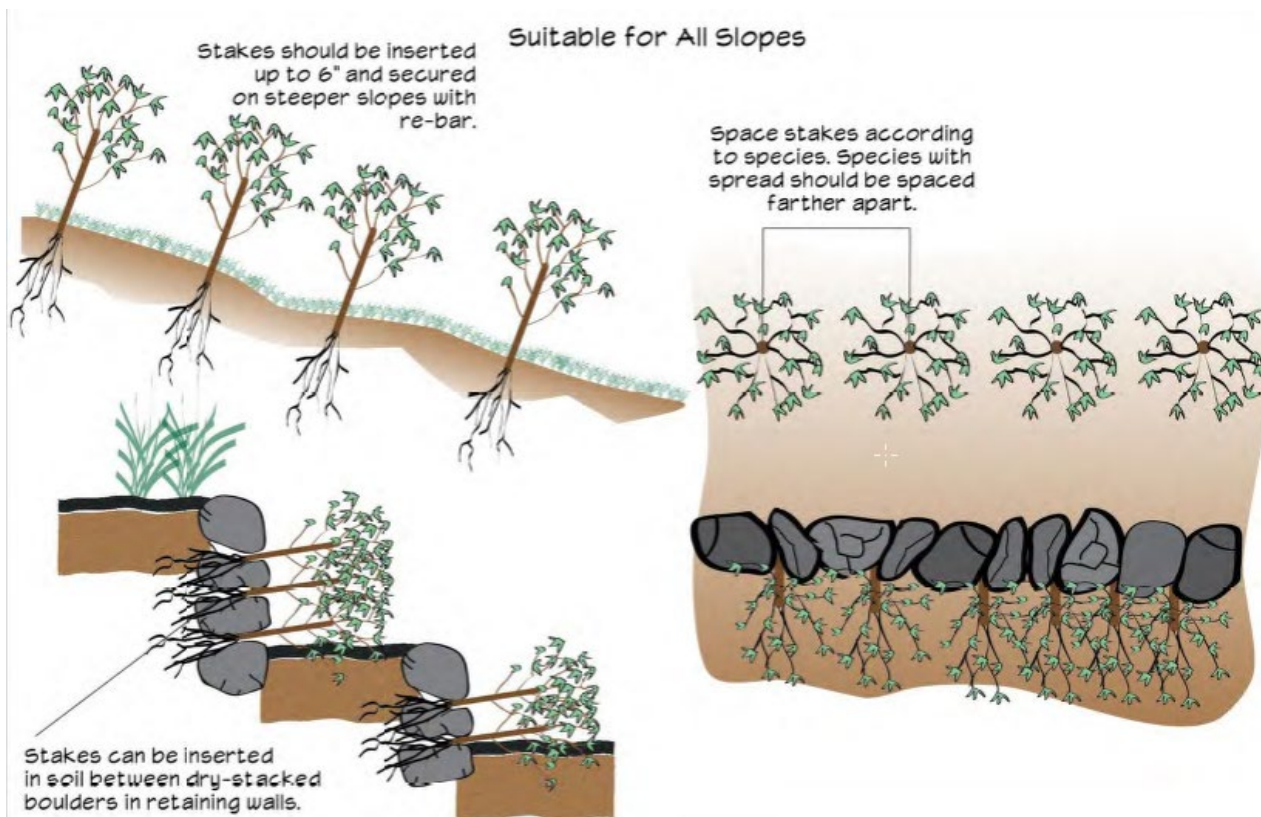
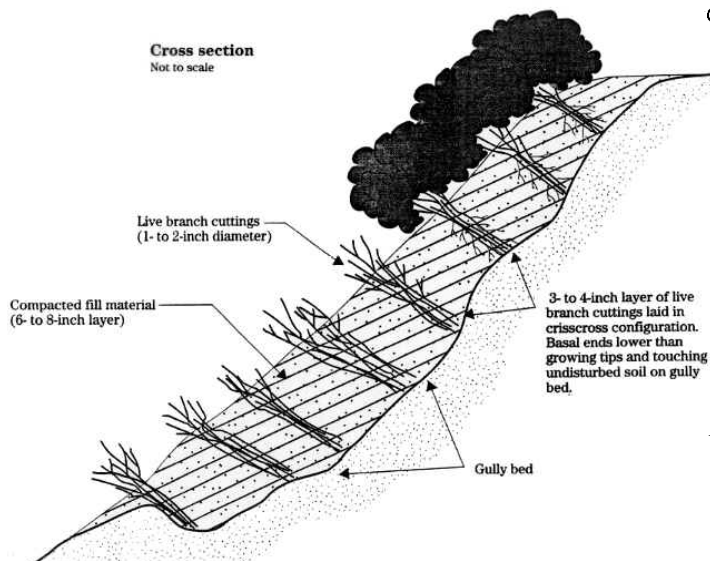
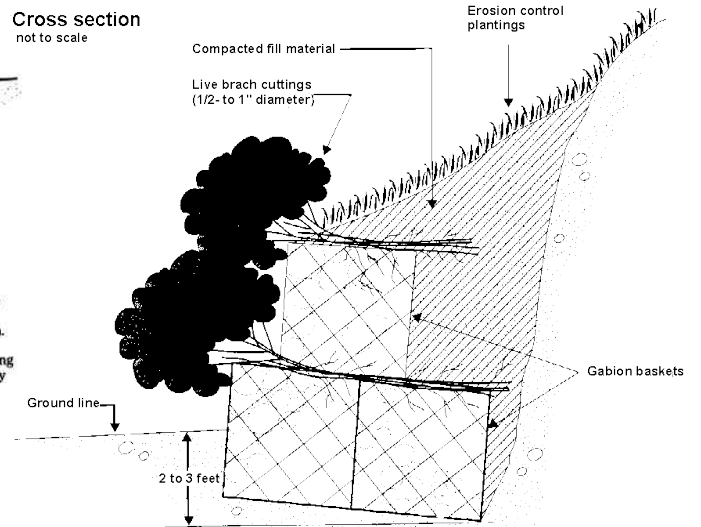

Figure 4.16 Examples of brush layering and tiered retaining walls. Methods for live staking based on length and diameter of cutting, cutting storage time, planting depth, etc. are described in CBCC, 2017. Types of plant species suitable to the US Virgin Islands recommended include *Ficus citrifolia*—wild fig or wild banyan tree, *Bursera simaruba*—turpentine tree, and *Plumeria alba*—wild frangipani.



**LIVE GULLY REPAIR**



**VEGETATED ROCK GABION**

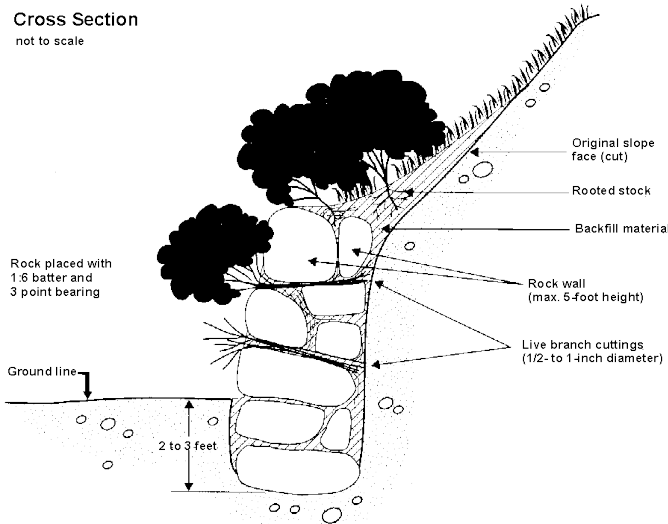

**VEGETATED ROCK WALL**

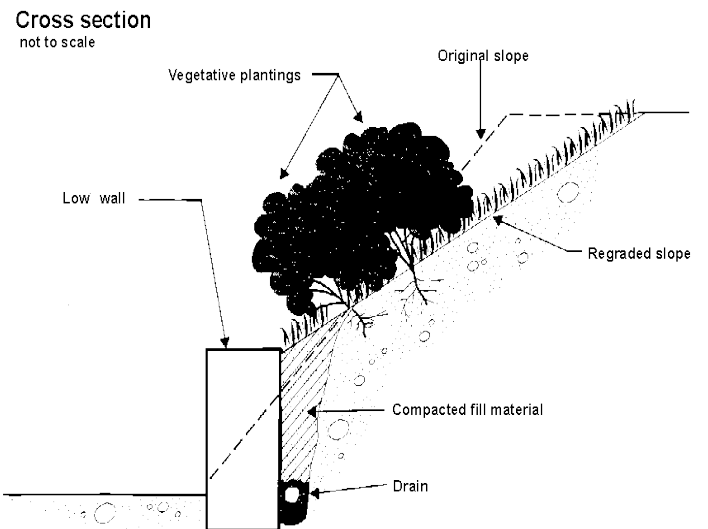

**LOW WALL (NON- REINFORCING PLANTINGS)**

Biotechnical installations are good for very steep slopes - 1:1 (100%) or more.

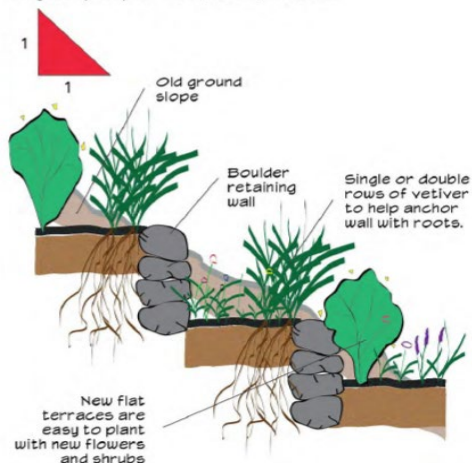

**TIERED WALLS/BENCH PLANTINGS**

Stagger vetiver plants for maximum root development and runoff control

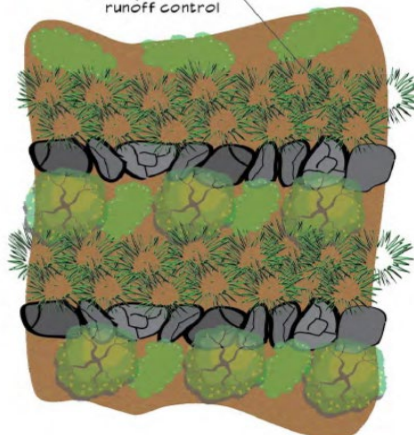

*Figure 4.17 Various types of soil bioengineering (from USDA-SCS, 1992 and CBCC, 2017). Note: rooted/leafed condition of the living plant material is not intended to be representative of the time of installation.*

## Minimum Plan Requirements

Details of soil bioengineering practices shall be shown on the plan and contain the following items:

- Type of soil bioengineering
- Calculations and stamp from licensed structural engineer, as necessary
- Amount of topsoil amendments proposed, if any
- Installation method and sequencing
- Plant species, size, source, and spacing
- Irrigation and maintenance requirements
- Removal method if needed for temporary applications

## Design

*Brush layering/live staking* is recommended on slopes up to 2:1 and that do not exceed 15 feet in vertical height. **Table 4.11** provides guidance on maximum slope length and bench spacing. Branch cuttings shall be ½ to 2 inches in diameter and long enough to reach the back of the bench. Side branches shall remain intact for installation.

Table 4.11 Brushlayer installation guidelines (USDA-SCS, 1992).

Slope	Bench Interval (feet)		Maximum slope length (feet)
	Wet slopes	Dry slopes	
2:1 to 2.5:1	3	3	15
2.5:1 to 3:1	3	4	15
3:1 to 4:1	4	5	20

*Live gully repair* is limited to gullies that are a maximum of 2 feet wide, 1 foot deep, and 15 feet long.

*Vegetated rock gabions* and *rock walls* are appropriate to use at the base of a slope where a low wall may be required to stabilize the toe of the slope and reduce its steepness. They are not designed for or intended to resist large, lateral earth stresses. They shall be built to a maximum 5-foot overall height, including the excavation required for a stable foundation. Vegetated rock gabions and walls are useful where space is limited, and a more vertical structure is required.

1. Starting at the toe of the slope, excavate benches horizontally, on the contour, or at an angle slightly

down the slope to aid drainage. The bench shall be built 2 to 3 feet wide.

2. Slope the surface of the bench so that the outside edge is higher than the inside.
3. Place live branch cuttings on the bench in a crisscross or overlapping configuration.
4. Align branch growing tips toward the outside of the bench.
5. Backfill soil on top of branches and compact to eliminate air spaces. Extend brush tips slightly beyond the fill to filter sediment.
6. Backfill each lower bench with the soil obtained from excavating the bench above.
7. Place long straw or similar mulching material with seeding between rows on 3:1 or flatter slopes, while slopes steeper than 3:1 require jute mesh, or a similar matting placed in addition to the mulch.
8. Space brush layers 3 to 5 feet apart, depending upon slope angle and stability.

## Installation

For *brush layering/live staking*, branch cuttings shall range from ½ to 2 inches in diameter. They shall be long enough to touch the undisturbed soil at the back of the wall and extend slightly from the rebuilt slope face.

For *live gully repair*, follow these installation guidelines:

1. Starting at the lowest point of the slope, place a 3- to 4-inch layer of branches at the lowest end of the gully perpendicular to the slope.
2. Cover branches with a 6- to 8-inch layer of fill soil.
3. Install the live branches in a crisscross fashion. Orient the growing tips toward the slope face with basal ends lower than the growing tips.
4. Follow each layer of branches with a layer of compacted soil to ensure soil contact with the live branch cuttings.

For *Vegetated Rock Gabions*, the branches shall range in size from ½ to 1 inch in diameter and must be long enough to reach beyond the back of the rock basket structure into the backfill. Install rock gabions following these guidelines:

1. Starting at the lowest point of the slope, excavate loose material 2 - 3 ft below the ground until a stable foundation is reached.

2. Excavate the back of the stable foundation (closest to the slope) slightly deeper than the front to add stability to the structure. This will provide additional stability and ensure that the branches root well.
3. Place the wire baskets in the bottom of the excavation and fill with rock.
4. Gabions can be stacked or terraced (tilted inward towards slope). Backfill between each layer of gabions and behind the wire baskets.
5. Place live branch cuttings on the wire baskets perpendicular to the slope with the growing tips oriented away from the slope and extending slightly beyond the gabions. The live cuttings must extend beyond the backs of the wire baskets into the fill material. Topsoil layer can be used in baskets to help establish plants. Place soil over the cuttings and compact it.
6. Repeat the construction sequence until the structure reaches the required height.
7. A layer of soil can also be installed on top of basket. Use filter fabric, erosion control matting, and/or smaller gravel layers between soil and gabions to prevent soil washout (**Figure 4.18**).

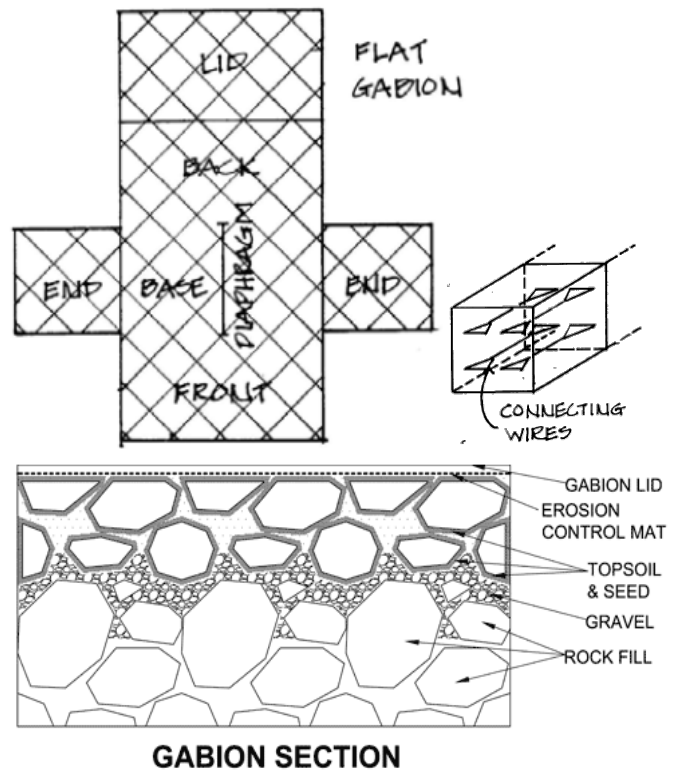

Figure 4.18 Gabion basket construction (from VT Better Backroads Manual and Source: Terraqua.com)

For *Vegetated Rock Wall* installations, live cuttings shall have a diameter of ½ to 1 inch and be long enough to reach beyond the rock structure into the fill or undisturbed soil behind. Use 8 to 24-inch diameter rock. Large boulders shall be used for the base. Install per the following guidelines:

1. Starting at the lowest point of the slope, remove loose soil until a stable base (such as bedrock) is reached. Excavate the back of the stable foundation (closest to the slope) slightly deeper than the front to add stability to the structure.
2. Excavate the minimum amount from the existing slope to provide a suitable recess for the wall.
3. Place rocks with at least a three-point bearing on the foundation material or underlying rock course. They shall also be placed so that their center of gravity is as low as possible, with their long axis slanting inward toward the slope.
4. When a rock wall is constructed adjacent to an impervious surface, place a drainage system at the back of the foundation and outside the toe of the wall to provide an appropriate drainage outlet.
5. Overall height of the rock wall, including the footing, shall not exceed 5 feet.

6. A wall can be constructed with a sloping bench behind it to provide a base on which live branch cuttings shall also be tamped or placed into the openings of the rock wall during or after construction. The butt ends of the branches shall extend into the backfill or undisturbed soil behind the wall.
7. The live branch cuttings shall be oriented perpendicular to the slope contour with growing tips protruding slightly from the finished rock wall face.

### Maintenance

- These practices are very low maintenance and self-repairing systems once the vegetation is fully established.
- Soil bioengineering practices should be inspected frequently while the vegetation is establishing, particularly after rain events.

- Any shifting, slumping, or erosion should be repaired immediately and replanted as necessary.
- May have to water until plants become established.
- May lose topsoil if fabric is punctured or improperly installed.

### Troubleshooting

- Vegetation not establishing well. Site may be too rocky for rapid growth. Add soil, irrigate more frequently, or choose a different species better suited to the conditions.
- Wrong practice chosen for a site. If continued slumping issues or slope failures occur, consider a more structural, rigid soil bioengineering practice or a soil retaining wall designed by a structural engineer.



*Vegetation may colonize gabion baskets overtime without human intervention.*





### 4.3 DIVERSIONS & CONVEYANCES

Once runoff is generated, it will need to be moved through a site without causing more erosion. Practices can be used to divert “clean” flows around disturbed areas where erosion could occur, slow velocities of erosive flows, or safely convey “dirty” flows into settling devices. Conveyances must be installed prior to extensive site clearing and sized to handle the peak flow from the 10-year, 24-hour Type II storm event for all contributing drainage area.



*Moving runoff through the site without causing erosion can be a challenge. Limiting drainage area contributions, stabilizing flow paths and slowing velocities are key strategies.*

Common practices include:

- **Diversion Berms:** Mounds of compacted sediment strategically placed to divert runoff to a stable outlet or settling device.
- **Diversion Swales:** Channels created to intercept and divert clean runoff or convey “dirty” runoff to stable outlet or trap device.
- **Pipe Slope Drain:** Enclosed pipe used to convey concentrated flow down a slope, often combined with a diversion berm at the top of the slope to direct runoff into the pipe and slope stabilization practices.
- **Check Dams:** Weirs of rock or other durable material installed across a channel (“in a smile”) to slow runoff and allow for settling.
- **Vegetated and Lined Waterways:** Permanent channels (grass, rock, matting, concrete) used to convey “clean” runoff from stabilized areas.
- **Gut Diversions and Isolations:** Pipes, channels, or cofferdams used to temporarily allow for construction in the dry in waterways or wet areas, such as culvert replacements or shoreline projects. Practices are not intended to permanently alter natural channels.

**Table 4.12** selection matrix compares the relative benefits of individual practices presented here. Contact DPNR for assistance in determining if other techniques not included here are acceptable.

*Table 4.12 Summary of diversion and conveyance devices and their benefits.*

Benefit	Diversion Berms and Swales	Pipe Slope Drains	Check Dams	Lined Waterways	Temporary Gut Diversions and Isolation
Easy to Install	●		●		
Inexpensive	●		●		
Handles Large Drainage Areas	●		●	●	●
Good for Steep Slopes		●	●	●	
Reduces Velocity			●		
Low Maintenance		●		●	

## DIVERSION BERMS AND SWALES

Berms and swales, depending on their location, can be used to divert “clean” runoff around disturbed areas, or to move “dirty” runoff to sediment traps. Diversion Berms, or “dikes,” are typically mounds of compacted earth, sand bags, or other impervious material used to interrupt and redirect flows. Diversion Swales are temporary channels used to convey runoff to a specific location.

### Minimum Plan Requirements

Details of diversion berms and swales shall be shown on the plan and contain the following items:

- Location(s) on site
- Berm/swale dimensions and stabilization methods
- Installation methodology
- Maintenance and removal requirements

### Design

1. Diversion berms and swales are appropriate for drainage areas  $\leq 2$  acres in size.
2. Size swales to convey the 10-year, 24-hour Type II storm from the contributing drainage area.
3. Berms are often used at the top of slopes or along the site perimeter to divert “clean” runoff from entering a highly erodible area. A common practice in the VI has been to create a debris berm using trees, stumps, and other vegetation that was cleared at the site. However, these are only marginally successful since water tends to find its way through the material and thus, it is ineffective at fully diverting the runoff and can lead to erosion.
4. Often, berms are combined with swales. Berms and swales should never be used to discharge dirty runoff to a gut or other waterway; sediment-laden runoff should be directed first to a sediment trap or basin.
5. If temporary berm and swales are to remain in place longer than 14 days, they must be stabilized using either vegetation, erosion control matting, geotextile, rip-rap, or some other material within 1

**Warning!** Unstabilized diversion berms or swales may create erosion and sedimentation problems of their own.



(Top) Diversion swale used to convey off site flows away from construction activity. (Bottom) Berm constructed at the perimeter of sediment basin to convey flows to a stabilized inlet into the basin (Guam EPA). White arrows indicate intended flow paths.

- week of construction. The type of stabilization method is dependent on the volume and velocity of the stormwater runoff to be conveyed.
6. All berms and swales must have a positive, uninterrupted grade to a stabilized outlet with a typical slope minimum of 0.5% to 20% maximum (8% max on combined berm/swales, or if not using erosion control matting or riprap).
7. **Figure 4.19** shows typical cross-sections for earth berms, diversion swales, and combined berm/swales.
8. Do not install diversion berms or swales to redirect existing streams around your site – see section on [Temporary Stream/Gut Diversions and Isolations below.](#)

### Installation

1. Diversion berms and swales should only be constructed inside the property boundary and should not negatively impact neighboring properties.
2. Remove and dispose of all brush, stumps, obstructions, and other objectionable material so

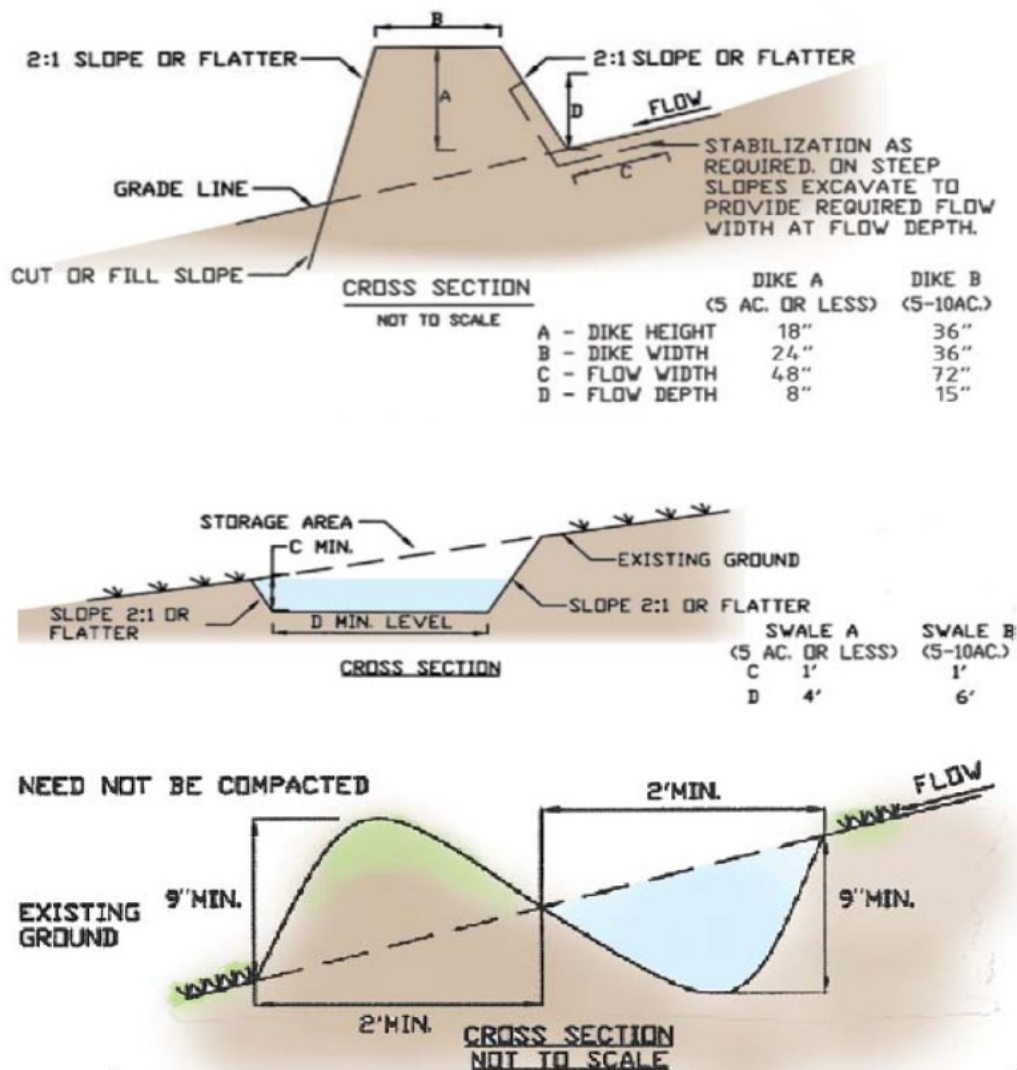

Figure 4.19 Typical cross-sections for earth berm (TOP), diversion swales (MIDDLE), and combined berm/swale structures (BOTTOM).

that they do not interfere with the functioning of the berm or swale.

- To prevent erosion, all berms should be compacted by heavy equipment, except for the combined berm/swale and sandbag berms.
- Diversion berm and swale outlets must slow runoff velocity to prevent erosion. If an outlet is not properly constructed, erosion can occur. Convey turbid runoff to a sediment trap to allow the suspended sediment to settle out.
- They should remain in place until the area they were built to protect is permanently stabilized.

### Maintenance

The full length of berms and swales should be inspected weekly and after every rain event in case of

damage. They should be repaired immediately to avoid further damage, erosion, and sedimentation.

### Troubleshooting

- The contributing drainage area is too large. Install additional practices upstream to reduce contributing drainage area and to prevent erosion and overtopping.
- Berms not stabilized. Stabilize exposed soils with temporary seeding, mulch, matting, or rock.
- Erosion at the outlet of the diversion berm/swale is occurring. Relocate or redesign outlet to slow runoff velocity and dissipate flow.

## PIPE SLOPE DRAINS

A pipe slope drain is a temporary pipe or flexible tubing with a stabilized entrance section, used where a concentrated flow of surface runoff must be conveyed down a slope without causing erosion.

### Minimum Plan Requirements

Details of pipe slope drains shall be shown on the plan and contain the following items:

- Location(s) on site
- Pipe type(s) and size(s)
- Inlet and outlet dimensions and stabilizations
- Installation methodology
- Maintenance and removal requirements

### Design

1. The maximum drainage area is 5 acre, but amount of runoff to each drain should be limited to that which can be conveyed without inlet erosion, blow outs at the outlets, and slope failure.
2. A diversion berm can be used at the top of slope to direct flow into drainpipe. The concentrated runoff can flow safely down the hill safely within the pipe to avoid erosion on the slope face (**Figure 4.20**).
3. Size pipe based on expected flows from given contributing drainage area (**Table 4.13**).
4. The inlet pipe leading to steep slope shall have a slope  $\geq 3\%$  to ensure positive drainage.
5. Use HDPE, corrugated metal pipe with watertight connecting bands, or flexible tubing of the same diameter as inlet pipe.
6. Discharge pipe drain to riprap apron, stabilized area, or sediment trap.
7. This practice is not for permanent use and should be used in concert with other slope stabilization (seeding, ECBs, etc.).

Table 4.13 Optimal Slope Drain Pipe Diameter

Maximum Drainage Area (acres)	Pipe Diameter (inches)
0.5	12
1.5	18
2.5	21
3.5	24
5.0	30



Example of a pipe slope drain used to temporarily convey driveway runoff to stone apron below unvegetated slope.

### Installation

8. Cover pipe inlet at least a foot with hand-compacted earth berm.
9. Create depression at inlet to help direct flows into pipe.
10. Securely anchor flexible tubing to the slope and at outlet with stakes, as needed.

### Maintenance

- Inspection of the inlet area, discharge location, and the anchors holding the drainpipe in place should be conducted after each rain event.
- Any needed maintenance should be performed immediately since slope erosion can cause significant problems.
- Maintenance might include removing debris from inlet to prevent clogging, removing sediment buildup, anchoring inlet pipe, or replacing with a larger pipe.

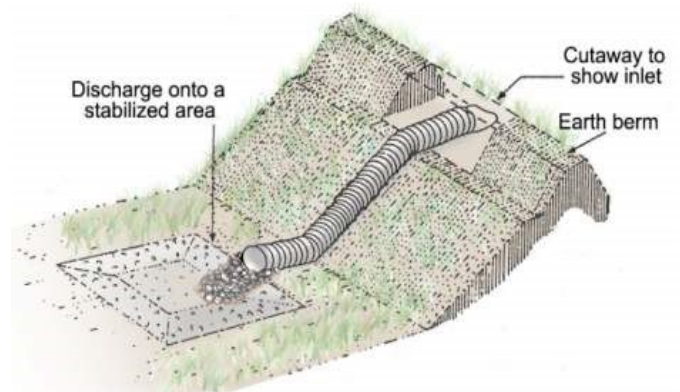

Figure 4.20 Berm-and pipe drain can be used when diverting water down a slope in the process of being stabilized.

## Troubleshooting

- Runoff not properly diverted to pipe inlet. Reposition pipe, re-grade inlet area with small depression, adjust berm to redirect runoff to inlet.
- Water ponding at top of slope. Remove debris and sediment from inlet pipe and replace with larger pipe, if needed.
- Erosion observed at discharge location. Adjust pipe to discharge to a stabilized area, replace/adjust riprap apron as needed.
- Pipe moves or becomes disconnected. Stake in place, replace connection bands.



*Rills and gullies indicate bypass of the pipe at the berm inlet. This may be due to lack of proper inlet design and/or the pipe diameter being too small. In addition, the pipe should be flexible, staked in place, and discharge to a stabilized area. Other than tracking, there does not appear to be any additional effort to stabilize the slope.*

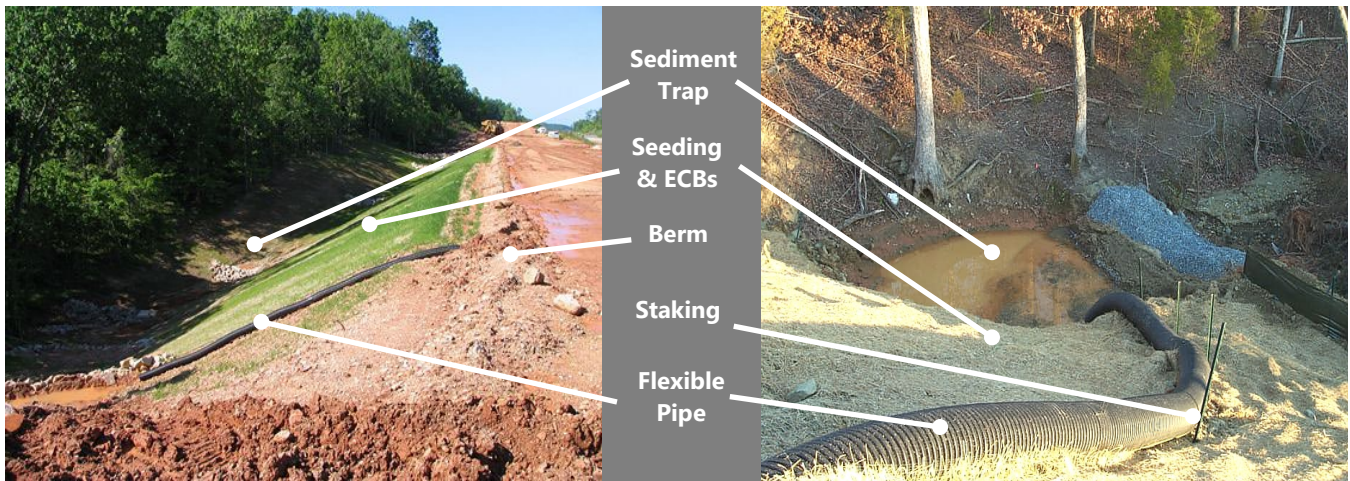

*Key elements of an effective pipe slope drain system.*

## CHECK DAMS

Check dams are structures constructed of stone, sandbags, compost socks, or other durable and flexible materials, used to slow down concentrated flows within a manmade channel to reduce erosive runoff flows and allow sediment to settle out. While check dams are most often temporary features on a construction site, check dams are sometimes included as part of the long-term stormwater management design for a given project. Similar to diversion berms and swales, install additional practices upstream to stabilize the contributing drainage area, and reduce runoff volumes to this practice.

### Minimum Plan Requirements

Details of check dams shall be shown on the plan and contain the following items:

- Location(s) on site
- Material types and sizes
- Check dam dimensions and spacing
- Installation methodology
- Maintenance and removal (if necessary) requirements

### Design

It is important to know expected erosion rates and runoff flow rates for the swale or channel in which this practice is to be installed. Contact DPNR's Division of Environmental Protection or a licensed engineer for assistance in designing this practice.

1. **Location** - A check dam should be installed in swales or channels >5% slope, or in swales where adequate vegetation cannot be established immediately. Check dams should not be built in natural streams or guts. They block normal streamflow, alter drainage patterns, and can lead to channel bypass and increased erosion. Check dams should be used only in small open, manmade channels and ditches that will not be overtopped by flow.
2. **Drainage Area** -To prevent sediment overloading and overtopping, the maximum drainage area above the check dam should not be larger than 2 acres.
3. **Dimensions** - The center section, or crest, of the check dam should be lower than the edges by at least 9 inches. In addition, the crest should not be higher than 2 feet higher than the bottom of the



*(Top) Series of small check dams correctly "smiling" in a drainage channel. (Bottom) Check dams with a crest elevation equal to side elevations (not smiling) has the potential to create runaround.*

- channel on the downstream side of the check dam (**Figure 4.21**).
4. **Material** - Use a well-graded stone matrix 2 to 9 inches in size. For other proprietary check dam materials, follow manufacturer's specifications. Silt fence is NOT a widely accepted material for check dam installations because: a) filter fabric ponds water and check dams need to allow flow through them, and b) silt fence does not have a flexible geometry to create the necessary "smiling" check dam shape. Combinations of rock and vetiver grass have been successfully demonstrated in Puerto Rico (**Figure 4.22**).
5. **Slope** - Channel side slopes should be 2:1 or flatter.
6. **Spacing** - Space dams as directed in the site plan (see **Table 4.14**). The top of the downstream dam should be at the same elevation as the toe of the upstream dam.

Table 4.14 Standard check dam spacing (MDE, 1994).

Slope	Spacing (ft)
<2%	80
2.1-4%	40
4.1-7%	25
7.1-10%	15
>10%	Lined waterway

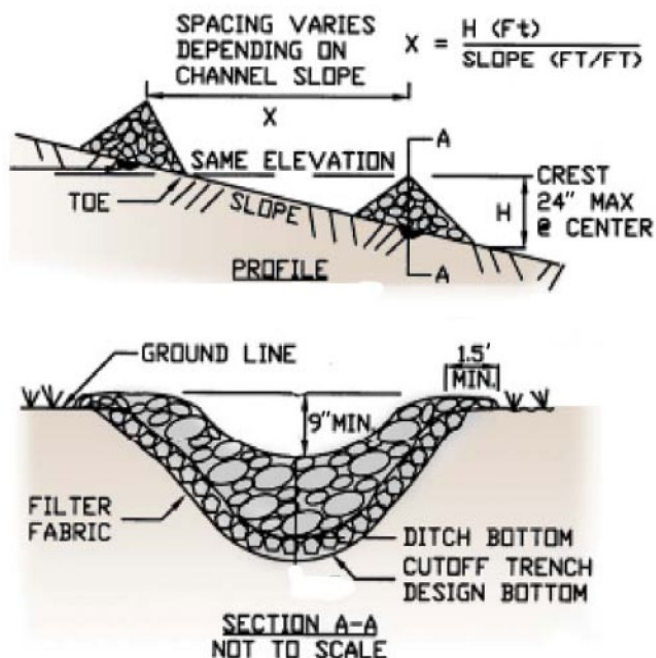

Figure 4.21 Proper spacing and cross-section of check dam.

### Installation

1. To firmly anchor check dams in place in the channel, excavate a cutoff trench 1 ½ feet wide by ½ foot deep and line with filter fabric.
2. To prevent runaround, make sure that the check dam is installed as designed so that it ties into the side slopes of the channel and appears as a “smile” rather than a speed bump.
3. After construction is complete, all stone should be removed if vegetative erosion controls will be used for permanent stabilization.

### Maintenance

- After each significant rainfall, check dams should be inspected for sediment and debris accumulation. Correct all damage immediately.
- Sediment should be removed when it reaches 1/2 the original dam height. Check for erosion at edges and repair promptly.
- Replace rocks as needed.



(Top) Check dam needs maintenance. Accumulated sediment should be removed, and the stone adjusted to extend across the full channel width to prevent bypass. (Bottom) Do not use silt fence for check dams. Checks should extend fully across ditch to prevent erosive bypass and have a lower center to allow for controlled spillover.

- Make sure culverts or other structures are not blocked by displaced check dam rocks.

### Troubleshooting

- Erosion between check dams. If this occurs, evaluate their spacing and install more check dams if needed. If erosion continues in the channel, consider installing a liner.
- Sediment accumulation behind dams. Remove sediment behind dam to allow channel to drain and prevent overtopping and check upstream sediment source for stabilization opportunities.
- Rocks of check dam are dislodged during large storm events. If this occurs, reduce the drainage area, install additional check dams, or use larger rock size and/or better anchoring.



Check dams are best used in channels (ditches). They can be vegetation only, or supplemented with hard-armoring (stones, shells, or concrete) for higher flows.

Plant double rows of vetiver (or similar) staggered and parallel to flow.

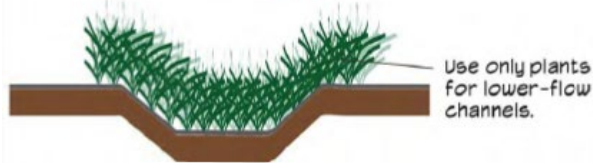
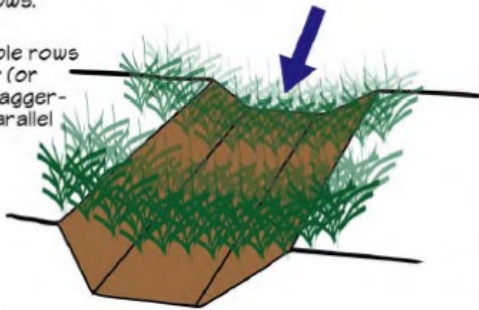

Use only plants for lower-flow channels.



Extend hard-armoring across entire channel and up side-slopes in higher-flow conditions.

Use hard-armoring for higher-flow areas.

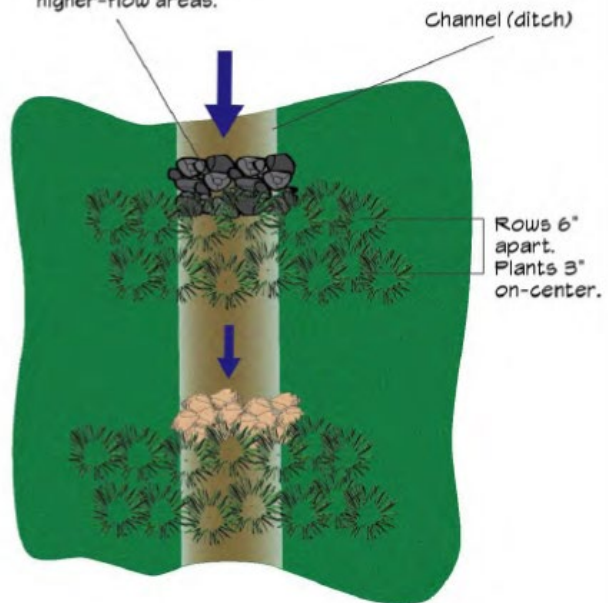

Rows 6" apart. Plants 3" on-center.

Figure 4.22. Combination vetiver and stone check dams in Culebra, PR. Vetiver check dam detail with armoring options for higher flow channels (from CBCC, 2017). The vetiver grass helps dissipate energy, trap sediment, and soak up standing water.



## VEGETATED AND LINED WATERWAYS

Vegetated and lined waterways or ditches are “armored” and used to safely convey otherwise erosive flows around the job site. These practices are a step up from dirt swales, are generally permanent, and are not intended to convey turbid flows from heavily eroding areas. Waterways are typically stabilized with grass, erosion control matting, rock rip rap, gabions, or concrete depending on slope, soil, and anticipated runoff velocity.

### Minimum Plan Requirements

Details of vegetated and lined waterways shall be shown on the plan and contain the following items:

- Location(s) on site
- Flow calculations
- Material type and size
- Installation methodology
- Maintenance and removal (if necessary) requirements

### Design

1. In general, vegetated channels are used for low to moderate slopes, while waterways lined with concrete or riprap are used for steeper slopes. Refer to **Table 4.15** for differences between, and requirements for, vegetated and lined waterways. Vegetated ditches that have  $< 5\%$  slope with grass in order to filter sediments. Use check dams or line ditches that have  $>5\%$  slope with rock. Combinations of rock lining and vetiver grass have been successfully demonstrated in Puerto Rico.
2. Vegetated and lined waterways typically have either a trapezoidal or parabolic (e.g., curved) cross-section, as shown in **Figure 4.23**.
3. Contact DPNR’s Division of Environmental Protection or a licensed engineer for assistance in designing this practice.

### Installation

1. Prior to installation, the path of the waterway must be cleared of trees, stumps, roots, loose rock, or other objectionable material.
2. The waterway should then be excavated and installed as directed by engineering plans. Do not



Examples lined waterways: (Top) erosion control matting; (middle) stone and grass; and (Bottom) concrete-lined waterway on a steep slope.

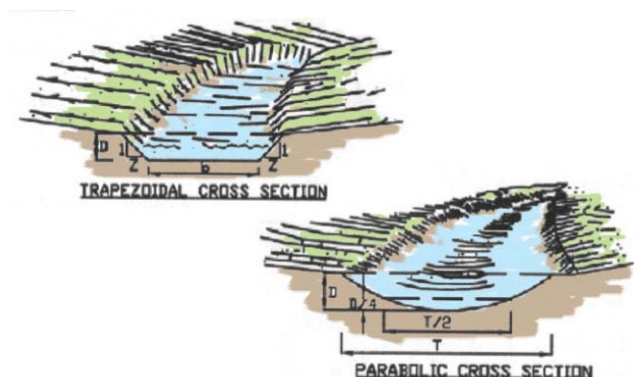

Figure 4.23 Typical channel cross sections for vegetated and lined waterways.

allow abrupt deviations from design grade or horizontal alignment.

3. Backfill over-excavated areas with moist soil compacted to the density of the surrounding material. Stabilize channels according to specifications.
4. It is important to follow the grade and alignment of the design plans and to stabilize the channel according to specifications to ensure proper functioning of the waterway.
5. Follow manufacturer’s instructions for installing erosion control matting in channels, including proper overlap of material and spacing of stakes (**Figure 4.24**).
6. Hard linings, such as concrete or riprap, should be installed as shown on the plans. For lined channels, non-woven geotextiles and cutoff walls may be used to prevent undermining.
7. At the discharge point, a stable outlet should be constructed to avoid erosion. **Figure 4.25** details a rip-rap channel on a slope.
8. Ideally, vegetated or lined channels should not be used until they are fully stabilized.

*Table 4.15 Differences between, and requirements for, vegetated and lined waterways.*

Vegetated Waterways	Lined Waterways
May require subsurface drainage or additional outlets to reduce wet spots.	Used when vegetation will not prevent erosion (>6% slope).
Seed with grass as soon as practical if low gradient (<3% slope).	Steepness of side slopes based on liner type.
Use erosion control matting, particularly along centerline at moderate gradient (3-6% slope).	Minimum lining thickness of 4 inches for concrete lining, or 1.5 times the maximum rock size for riprap. Use 2-6 in diameter stone with 7.5-inch liner thickness (5-10% slope). Use 12-inch-thick liner of 3-12-inch rock (>10% slope).
Vegetation must be established before use.	Weep holes and underdrains should be provided for concrete.

### *Installing Erosion Control Blankets in a Channel*

Prepare area as described above and install and secure blanket according to manufacturer’s instructions,

generally as follows:

1. Install ECB in the direction of water flow and ensure that it is in constant contact with the ground (to prevent erosion under the mat).
2. Begin at the top of the channel by anchoring the top end of the ECB in a 6" deep X 6" wide trench with approximately 12" of ECB extended beyond the up-slope portion of the trench.
3. Anchor the ECB with a row of staples or stakes approximately 12" apart in the bottom of the trench.
4. Backfill and compact the trench after stapling. Apply seed to compacted soil and fold remaining 12" portion of ECB back over seed and compacted soil. Secure ECB over compacted soil with a row of staples/stakes spaced approximately 12" apart across the width of the ECB.
5. Roll center ECB in direction of water flow in the bottom of the channel. ECBs will unroll with appropriate side against the soil surface. All ECB s must be securely fastened to soil surface by placing staples or stakes in appropriate locations as shown in the staple pattern guide provided by the manufacturer.
6. Place consecutive ECBs end over end (shingle style) with a 4" - 6" overlap. Use a double row of staples staggered 4" apart and 4" on center to secure ECBs.
7. Full length edge of ECBs at top of side slopes must be anchored with a row of staples/stakes approximately 12" apart in a 6" deep X 6" wide trench. Backfill and compact the trench.
8. Adjacent ECBs must be overlapped approximately 3" - 6" (depending on mat type) and stapled.
9. In high flow channel applications, a staple check slot is recommended at 30-to-40-ft intervals. Use a double row of staples staggered 4" apart and 4" on center over entire width of the channel.
10. The downstream ends of the ECBs must be anchored with a row of staples/stakes approximately 12" apart in a 6" deep X 6" wide trench. Backfill and compact the trench after stapling. Horizontal staple spacing should be altered, if necessary, to allow staples to secure the critical points along the channel surface. In loose soil conditions, the use of staple or stake lengths greater than 6" may be necessary to properly anchor the ECBs.

## Maintenance

If lining, matting, or other constructed material was installed in the vegetated/lined waterway, the lining material should be maintained to prevent undermining and deterioration. Also, maintaining vegetation cover on slopes and banks is one of the most effective ways to keep them stabilized. For vegetated and lined waterways, maintain vegetation as needed and keep banks of the waterways stabilized.

## Troubleshooting

- Vegetation does not grow/establish. If this occurs, use erosion control matting prior to use.
- Waterways are overwhelmed with excess flow. If this occurs, install additional outlets or an underdrain system to handle these flows.
- Out-of-bank flows occur. Reduce the volume of flows entering the channel or redesign the channel to accommodate larger volumes.
- Gullies are forming in a vegetated channel. Use a liner in centerline of vegetated channel.
- Erosion occurs beneath a rock-lined channel. Make sure the filter fabric layer was installed correctly.

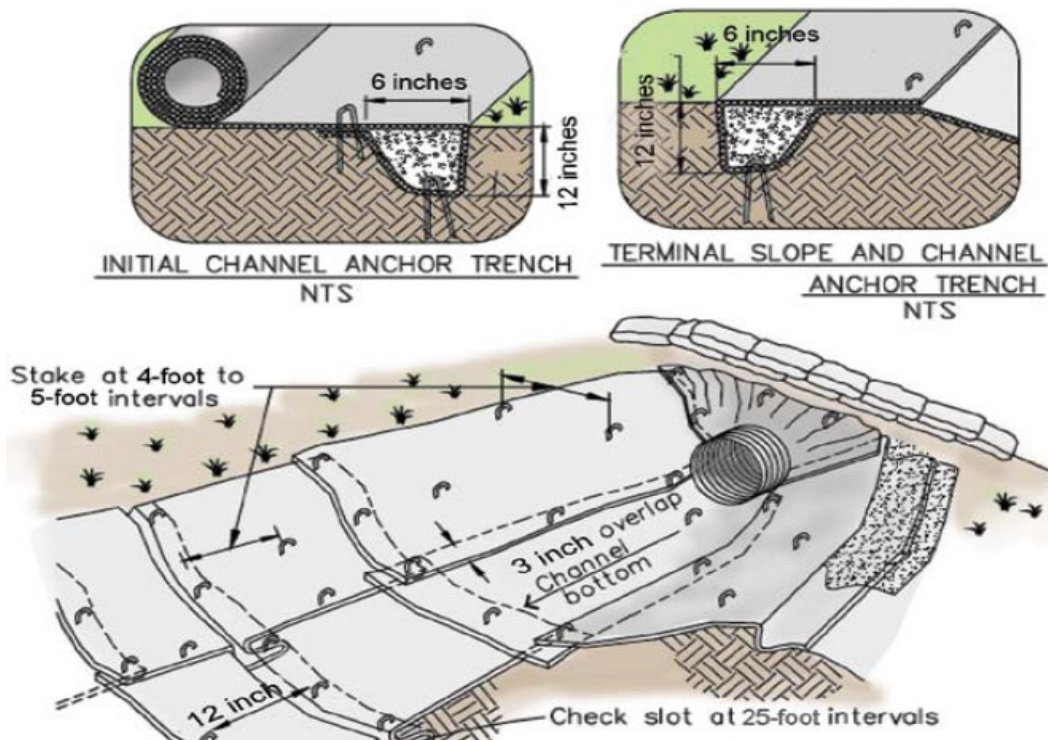

Figure 4.24 Diagram of erosion control matting used to line channel (Adapted from CalDOT, 2009).



Figure 4.25 Rip-rap channel (source: VT Unpaved Road BMP Manual)

## TEMPORARY DIVERSIONS & ISOLATIONS

For culvert, bridge, or shoreline projects, it may be necessary to isolate the construction area from surrounding waters to create a dry workspace and to minimize contact of flowing water with exposed soils. The USVI doesn't have many perennial streams (i.e., guts that flow continuously), but temporarily diverting dry guts may be important to protect the immediate area of construction during wet weather flows. It is critical that activities located in water resource areas are properly permitted, designed, and maintained.

### Minimum Plan Requirements

Details of the temporary gut diversion and isolation practices shall be shown on the plan and contain the following items:

- Location(s)
- Flow calculations
- Material types and sizes
- Diversion/isolation dimensions
- Installation methodology and schedule
- Maintenance and removal requirements

### Design

Temporary gut diversions and isolation practices are highly dependent on expected flows and could cause a public safety hazard and other environmental issues if not designed correctly. It is important to specify the appropriately sized practice (and pumps, if needed) for the length of the site and anticipated flows. Contact DPNR's Division of Environmental Protection or a licensed engineer for assistance in designing this practice.

1. *Cofferdams*, portodams, or dikes, are used to isolate the work area from a surrounding waterbody. They can be made from welded metal sheet piling, inflatable bladders, sandbags, or other materials.
2. *Piped diversions* and *temporary channels* can also be used to convey guts around construction areas until the site has been stabilized. Channels should be stabilized with stone, liners, or erosion control blankets. Pumps or the natural current will move water through these diversions. Photos of temporary channels and a schematic illustrating a lined channel diversion using a dewatering device are shown in **Figure 4.26**. Size channels to convey



(Top) Examples of cofferdams made from sheet metal and (middle) sandbags (photos from NCDOT), and (middle) inflatable bladder. (Bottom) Silt fence may not be best choice.

**Warning!** Temporary gut diversions require a permit. Check with local permitting agencies when planning this type of work.

at least the 2-yr storm with a maximum of 2:1 side slopes. Protect channel and top of bank from erosion (e.g., liners for channels; berms/silt fence for top of bank). Do not install diversions in fill material. Do not use earthen dams.

### Installation

Installing cofferdams or other temporary diversions to work in a water body requires care to avoid damaging the resource area.

1. Most guts in the USVI are ephemeral (only flowing when raining), but schedule work for the dry season to reduce the risk of runoff.
2. Minimize the amount of disturbance at diversion points to the greatest extent practicable. It is important to follow the design specifications and to specify the dewatering procedures.
3. When locating a temporary diversion, do not install the diversion structure in fill material.
4. Do not use earthen dams because they will not provide adequate isolation of the work area. You must protect the channel with liners and stabilize the top of bank with berms and/or silt fence. Use geotextile and/or stone below pipes.

5. Anchor pumps and pipes securely and ensure a good seal for cofferdams by properly preparing the sub-grade.

### Maintenance

Inspect and monitor daily to make sure coffer dams are functioning properly. Where pumps are being used, inspect on an hourly basis. Make sure erosion is not occurring upstream or downstream of the diversions and that channel side-slopes are stable.

### Troubleshooting

- The practice(s) and pump(s) may not be sized appropriately. Check sizing calculations and revise as necessary.
- Erosion of channel and diversion points can also occur. Stabilize area with appropriate erosion control practices.
- Leaks in cofferdams can also occur. Depending on the type of the dam, reset the structure, remove any debris, or add an impermeable liner to re-create a proper seal.

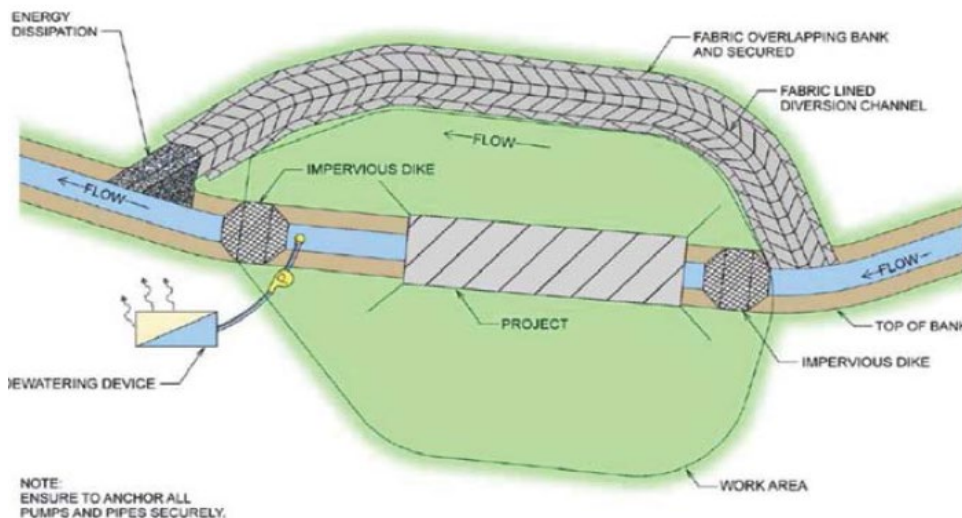

Figure 4.26 (top) Photos of piped and lined-channel diversions (sources: Fisheries and Oceans Canada), and (bottom) a schematic illustrating a channel diversion with impervious dikes and a dewatering device (NC DOT, 2003).



## 4.4 SEDIMENT TRAPPING DEVICES

The following section reviews various sediment control practices that collect runoff and trap sediments prior to any off-site discharge. Practices used to remove sediment from runoff include settling and dewatering devices. While these practices are effective at trapping sediment on site, they do not prevent erosion. Many of these practices are a “last resort” for keeping sediment on site.

*Settling devices*, such as sediment traps and basins, temporarily pond sediment-laden runoff from construction sites or unpaved roads. These ponding structures are formed by an embankment and/or excavation. The number and location of traps/basins will depend on site topography and drainage area size (**Figure 4.27**). Gravity will force particulates to settle out of the water column if the residence time is long enough, allowing “cleaner” overflows to eventually drain out from the top of the water column. Depending on settling time, length of flow path, and other design features, these practices can remove down to medium silt particle size.

Runoff with finer silts and clays will pass through untreated once the ponding capacity is exceeded. As such, upgradient erosion prevention and reduction of velocities prior to settling devices is critical. Stabilized conveyances carry flows to settling devices. Traps and basins should NOT be built in a stream or gut—the creation of a dam at these sites will result in destruction of aquatic and moist forest habitats, and flooding may result from dam failure.



*Particulates will settle out of the water column if given enough time. Trapping devices like sediment basins must be sized to manage expected flows and maintained to ensure capacity.*

*Dewatering devices*, such as sump pits, sediment bags, containment areas, and weir tanks are used to remove water generated by storms or high groundwater that has ponded in work areas. Water is pumped into a dewatering practice and through a filtering media or baffle system to trap the sediment prior to discharge. Dewatering devices can also be used to drain down sediment basins and traps.

**Table 4.16** provides a simple selection matrix for comparing the relative benefits of individual practices presented here. Contact DPNR for assistance in determining if other techniques not included here (paving, chemical binders, etc.) are acceptable.

*Table 4.16 Summary of sediment trapping devices benefits.*

Benefit	Sediment Traps	Sediment Basins	Dewatering
Effective for smaller particles		●	●
Easy to Install	●		
Inexpensive	●		
Handles Large Drainage Areas		●	●
Good for Steep Slopes		●	●
Can be converted to post-construction practice	●	●	
Low Safety Issues	●		●
Low Maintenance	●		

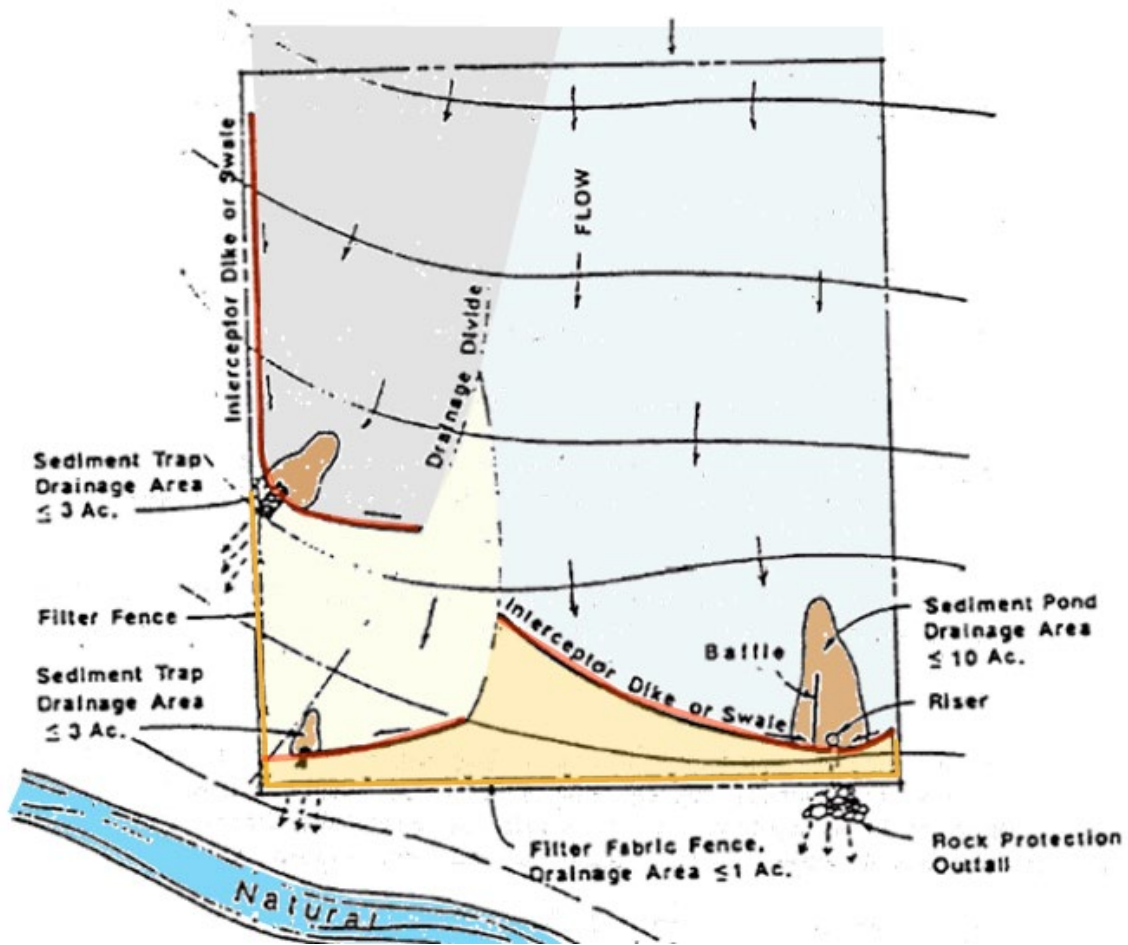

Figure 4.27 The placement of traps and basins on a site should be based on topography and size of drainage areas. The benefit of breaking up the drainage areas and providing redundancy can be an important design element of erosion control planning.

## SEDIMENT TRAPS

*Sediment traps* are temporary ponding structures with simple rock outlets used to collect runoff and allow sediment to settle out before slowly allowing cleaned runoff to leave the site (**Figure 4.28**). Traps are formed by an embankment and/or excavation, and they capture and contain sediment and sediment-laden runoff that are generated during construction activities. These devices are intended to be temporary, for managing drainage areas that will be disturbed for 6 months or less. The primary differences between basins and traps are their size and the drainage areas they are designed to capture. **Table 4.17** provides more details on the differences between sediment traps and sediment basins.

Table 4.17 Differences between sediment basins and traps.

	Traps	Basins
Max Drainage Area	1 acre	10 acres
Size	3,600 ft <sup>3</sup> /acre of drainage; >2:1 length to width Can use multiple cells and baffles	
Dam Height	5 ft max	10 ft max
Dam Width	4 ft min	8 ft min
Dam Side Slopes	2:1 or flatter	
Outlet, if needed	Rock outlet	Riser with spillway
Riser Height	NA	2 ft below top of dam, 1 ft below emergency spillway
Build-out Timeframe	6 months or less	36 months or less
Status	Temporary	Temporary/can be converted to Permanent

### Minimum Plan Requirements

Details of proposed sediment traps shall be shown on the plan and contain the following items:

- Location(s)
- Sizing calculations and trap dimensions
- Material specifications, as needed
- Outlet/spillway dimensions
- Installation methodology
- Maintenance and removal requirements

### Design

1. **Site Suitability:** Sediment traps are suitable for small drainage areas and should be installed at stormwater discharge points from a disturbed area



Sediment trap excavated along a construction access road on the east end of St. Thomas.

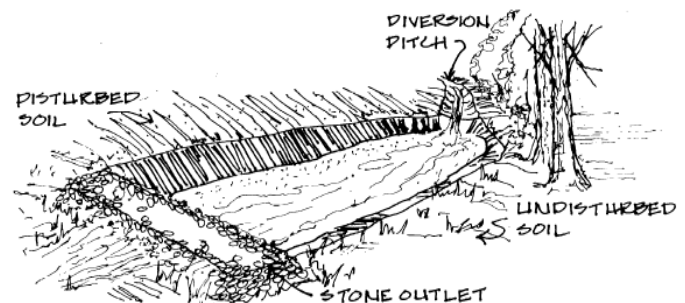

Figure 4.28 Sediment trap schematic (from MA Unpaved Road BMP Guide)

of 1 acre or less that will be constructed in six months or less. Sediment traps should NOT be used to artificially break up a natural drainage area into smaller sections where a larger device (sediment basin) would be more appropriate. They should be located at least 20 feet away from an existing building foundation.

2. **Minimum Volume:** Sediment traps should be sized to hold 3,600 cubic feet per acre of drainage area contributing stormwater to the practice. Traps should be twice as long as wide to increase the distance between the inlet and outlet. For tight or steep sites, trap may be built with several cells, as long as the spillway from each cell is stabilized and the total volume meets the minimum requirement.
3. **Embankments:** Embankment height should not exceed 5 feet and should have a minimum 4 foot wide top and side slopes of 2:1 or flatter.
4. **Stabilization:** Stabilize inlets, side slopes, and embankments. Use vegetation where practical to stabilize side slopes. Grass can be used on the embankments, but not woody plants like trees and shrubs. Where grass is not practical, stabilize with erosion control blankets or rock.



5. **Outlets:** Outlets should be designed using a gradient of rock to slow and filter runoff to minimize sediment leaving the trap. See **Figure 4.29** for details on the rock outlet. Outlet should discharge to a flat stabilized surface or lined waterway so that erosion does not occur. Rock should extend fully across width of trap. Use anchor trench with separating geotextile.
6. **Public Safety:** The design of temporary sediment traps is very important to ensure public safety as well as to capture sediment. Contact DPNR's Division of Environmental Protection, USDA Natural Resources Conservation Service, the UVI Cooperative Extension Service, or a licensed engineer for assistance in designing this practice.

### Installation

1. Sediment traps should be constructed before major earth-moving activities begin.
2. Construction of embankments and traps must comply with all engineering specifications.
3. Use backhoe or small excavator for excavation. Minimize damage to surrounding trees.
4. Embankments must be properly compacted during construction.
5. Locate traps to obtain maximum storage, ease cleanout, and minimize interference with construction activities. Maximize distance between inlet and outlet/overflow.
6. Stabilize all side slopes and inlets.
7. Outlets should be constructed to minimize sediment from leaving the trap and erosion from occurring below dam. Ensure outlet crest is lower than embankment.

### Maintenance

- The useful life of a sediment trap depends on regular maintenance; however, a trap's design life is typically only 6 months or so. Sediment traps should be readily accessible for maintenance and sediment removal. They should be inspected after each rainfall event, particularly the embankments and outlets. Repair any damage immediately.
- Remove accumulated sediment when original design volume is reduced by half (e.g., install a sediment marker for easy depth determination). Dispose of sediment according to approved site plan. In no case should removed sediments be



*Trap design variant with rock-line side slopes and outlet with vetiver grass on bottom for trapping sediment.*



*Create a rock filter using smaller sized rock on the inside of rock outlets (Clemson University).*

disposed of in guts, wetlands, or other natural areas.

- Do not remove sediment trap(s) until the site has been fully stabilized for at least 30 days. Remove water by pumping into a dewatering device prior to removing dam. Do not allow sediment to flush into a gut or drainage way.

Sediments must be removed, safely disposed of, and backfilled with a structural fill. All sediment traps should be graded and vegetatively stabilized.

### Troubleshooting

- Outlet rock becomes clogged with debris. Remove, clean, and reinstall stone filter. Consider options for lengthening the flow path or amount of time for particulate settling to occur. Look for opportunities to stabilize the contributing drainage area.
- Slopes of trap erode. Stabilize with rock, vegetation or matting.
- Sediment buildup occurs at inlet or outlet. Remove sediment. Do not allow sediment to build up higher than 1 foot below the spillway.
- Sediment buildup continues. Upstream drainage area may be too large. Have an engineer check drainage area calculations and/or use other or additional practices to limit sediment input.
- Embankment washes out. This could be caused by several factors: upstream drainage area may be too large/the trap may be too small, the embankment was not properly compacted, or



*Remove accumulated sediment when trap capacity is less than 1/2 the design volume to avoid a situation where there is not enough storage capacity for the next storm event.*

the rock outlet was not wide enough. Rebuild larger if needed and stabilize, ensuring that sizing of all components is appropriate for the site.

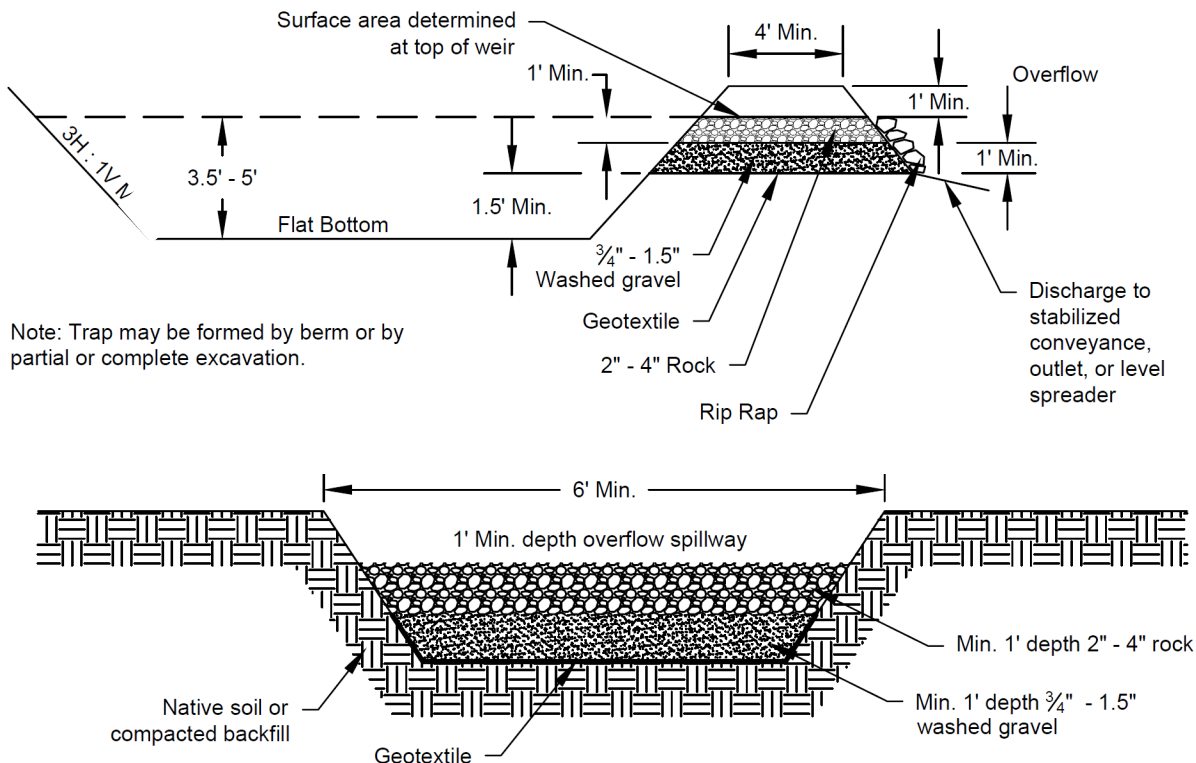

Figure 4.29 Cross Section of Sediment Trap (upper graphic) and the Sediment Trap Outlet (lower graphic). (WADOE, 2014)

## SEDIMENT BASINS

*Sediment basins*, much like sediment traps, are settling devices that capture and contain sediment and sediment-laden runoff that are generated during construction activities. Basins are also formed by an embankment and/or excavation. These devices are usually intended to be temporary; however, in some cases, sediment basins can be designed to become a permanent feature of a site.

### Minimum Plan Requirements

Details of proposed sediment traps and basins shall be shown on the plan and contain the following items:

- Location(s)
- Sizing calculations and basin dimensions
- Material specifications, as needed
- Outlet dimensions
- Installation methodology
- Maintenance requirements and sequence of removal or conversion to post-construction conditions (permanent detention pond)

### Design

- **Suitability:** These criteria apply to basin design sites where: (a) failure of the structure would not result in loss of life, damage to homes or buildings, or interruption of use or service of public roads or utilities; (b) the drainage area does not exceed 10 acres; (c) embankment heights are not greater than 10 feet; and (d) the basin is to be removed within 36 months after the basin construction. Basins that exceed any of these thresholds shall be designed according to Federal Guidelines for Dam Safety (FEMA, 2004) and USDA-NRCS's Technical Release 210-60: Earth Dams and Reservoirs (2019) at a minimum.
- **Site Constraints:** Sediment basins should NOT be placed in natural drainage channels/guts. They should be located at least 20 feet away from an existing building foundation. If the basin is located near a residential area, it is recommended for safety reasons that a sign be posted (child hazard, no playing) and that the area be secured by a fence.
- **Minimum Volume:** Sediment basins should be sized to hold at least 3,600 cubic feet per acre of drainage area contributing stormwater to the practice. They can be designed to maintain a permanent pool or to drain completely dry.



Examples of sediment basins (bottom photo: Guam EPA)

- **Basin Dimensions:** Basins should be at least twice as long as wide to increase the distance between the inlet and outlet for better sediment removal via settling, while three to six times as long is preferred. For tight or steep sites, basins may be built with several cells, as long as the spillway from each cell is stabilized and the total volume meets the minimum requirement. Advanced basin designs include a baffle system to increase the residency time for particles to settle out. The outlet structure may also include a floating skimmer that restricts drainage to the outlet structure from the upper levels of the water column.
- **Riser Outlet Structure (Principal Spillway):** For riser outlet structures, all pipe connections should be watertight. Dewatering holes in the base of riser pipes may be wrapped in filter cloth or washed stone, but these can clog easily depending on how fine sediment particles are, so inspect often to determine when maintenance is needed. Do not cover top of riser, unless with a trash rack. The riser shall have the capacity to handle the peak flow from a 10-year, 24-hour design storm, with a minimum diameter of 10 inches and maximum height of

10 feet. To determine appropriate riser diameter for your site, see riser inflow curves in **Figure 4.30**. The top of the riser should be at least 1 ft below the emergency spillway crest.

- **Anti-vortex device and trash rack:** An anti-vortex device and trash rack shall be securely installed on top of the riser.
- **Base:** The riser base shall be attached to the riser with a watertight connection and have sufficient weight to prevent flotation of the riser. Typical bases consist of concrete or steel plates with dimensions at least twice the riser diameter.
- **Outlet Pipe:** The outlet pipe should be designed by an engineer with a capacity for the peak flow from the 10-year, 24-hour design storm. All pipe material shall be of good quality with no holes, with watertight connections. Outlet protection should be used at the downstream end to prevent erosion. If discharges are at the property line, drainage easements will be obtained in accordance with DPNR requirements. Do not use pervious materials such as sand or gravel as backfill around pipe.
- **Anti-seep Collar:** An anti-seep collar with watertight connections shall be used and placed 25 feet from the riser. Do not use pervious materials such as sand or gravel as backfill around anti-seep collar.
- **Emergency Spillway:** An emergency spillway is required and should be designed by an engineer to safely convey the peak flows from the 100-year, 24-hour design storm if the principal spillway (riser) is completely blocked. Typical spillways are trapezoidal, with a minimum of 8-ft bottom width and 2:1 side slopes. Spillway design capacity should be analyzed as a broad crested weir. The spillway should be stabilized by vegetation or rock based on anticipated velocities. There should be a minimum of 1 ft of freeboard between the spillway and top of the embankment.
- **Embankment:** Sediment basin embankment height should not exceed 10 feet and should have a minimum 8 foot wide top and side slopes of 2:1 or flatter. Embankments greater than 6 ft should be designed by a professional engineer with geotechnical expertise and meet all necessary dam safety requirements. Embankment material shall be clean soil free of roots, woody vegetation, large rocks or other



*Residence time is too short for this pond to be effective, as evident by the short distance between the inlet as outlet as well as the relatively low outlet invert elevation.*



*Vertical standpipe – should be perforated, wrapped with geotextile fabric or a rock filter.*

objectionable material. Do not use pervious materials such as sand and gravel. Place material in 8-in layers and continuously compact to a minimum 95% of the Standard Proctor Maximum Density, ASTM Procedure D698.

- **Cutoff Trench:** A cutoff trench should be designed along the centerline of the embankment that is a minimum of 2 ft deep with a 4-ft wide base and minimum 1:1 side slopes. The cutoff trench should be compacted and extend up both abutments to the riser crest elevation.
- **Stabilization:** All side slopes, inlets, and basin outlets (including spillway/energy dissipater) should be stabilized. If a sediment basin is intended to be permanent, the temporary riser will need to be replaced with a permanent water quality control outlet structure (see **Chapter 5**).

## Installation

1. Sediment basins should be constructed before major earth-moving activities begin.
2. Construction of embankments, basins, and traps must comply with all engineering specifications. Embankments must be properly compacted during construction.
3. Locate basins to obtain maximum storage, ease cleanout, and minimize interference with construction activities. Maximize distance between inlet and outlet.
4. Confirm that riser and pipe connections are watertight.
5. Dewatering holes in base of riser should be covered by filter fabric or rock. No holes allowed in outflow pipe.
6. Outlets should be constructed and maintained to minimize sediment leaving the basin and erosion from occurring below outlet/dam.
7. Stabilize all side slopes, inlets and basin outlets (including spillway/ energy dissipater).

## Maintenance

The useful life of a sediment basin depends on regular maintenance. Sediment basins should be readily accessible for maintenance and sediment removal. They should be inspected after each rainfall event, particularly the embankments and discharges. Embankments should be kept clear of trees. Repair any damage immediately.

Accumulated sediment should be removed when original design volume is reduced by half (e.g., mark height on riser or sediment marker) OR when it has built up to one foot below the top of the riser. Dispose of sediment according to approved site plan. In no case should removed sediments be disposed of in guts or other natural areas. Do not remove sediment basin(s) until the site has been fully stabilized for at least 30 days. Remove water using properly sized dewatering practices prior to removing dam. Do not allow sediment to flush into a gut or drainage way. Sediments must be removed, safely disposed of, and backfilled with a structural fill. A well-built temporary sediment basin that is large enough to handle post-construction runoff volume may later be converted to use as a permanent stormwater management structure (see **Chapter 5**). If converting to permanent practice, sediment basin should be dewatered, cleaned, and re-graded to meet new design specifications.



*Excavation of accumulated sediment during maintenance of sediment basin. Note outlet pipe with trash rack and baffle.*

## Troubleshooting

The most common structural failure of sediment basins is caused by *pipng*. Piping refers to two phenomena: (1) water seeping through fine-grained soil, eroding the soil little by little and forming “pipes” or tunnels; and (2) water under pressure flowing upward through a granular soil with a head of sufficient magnitude to cause soil grains to lose contact and capability for support. The most critical construction actions required to prevent piping are:

- Tight connections between riser and all pipes.
- Adequate anchoring of riser.
- Proper soil compaction of the embankment and riser footing.
- Proper construction of anti-seep devices.

### *Other Common Problems:*

- Outlet pipe becomes clogged with debris. Clean pipe and reinstall filter fabric or stone filter. Consider options for lengthening the flow path or amount of time for particulate settling to occur. Look for opportunities to stabilize the contributing drainage area.
- Slopes of basin begin to erode. Stabilize with rock, vegetation, or matting.
- Sediment buildup occurs at an inlet or outlet. Remove the sediment. Do not allow sediment to build up to an elevation >1 ft below the spillway.
- Sediment buildup continues at rapid rate. This may indicate that the upstream drainage area may be too large. Have an engineer check the drainage area calculations and/or make sure other stabilization practices are used to limit sediment input. Consider breaking the drainage up and having multiple basins.

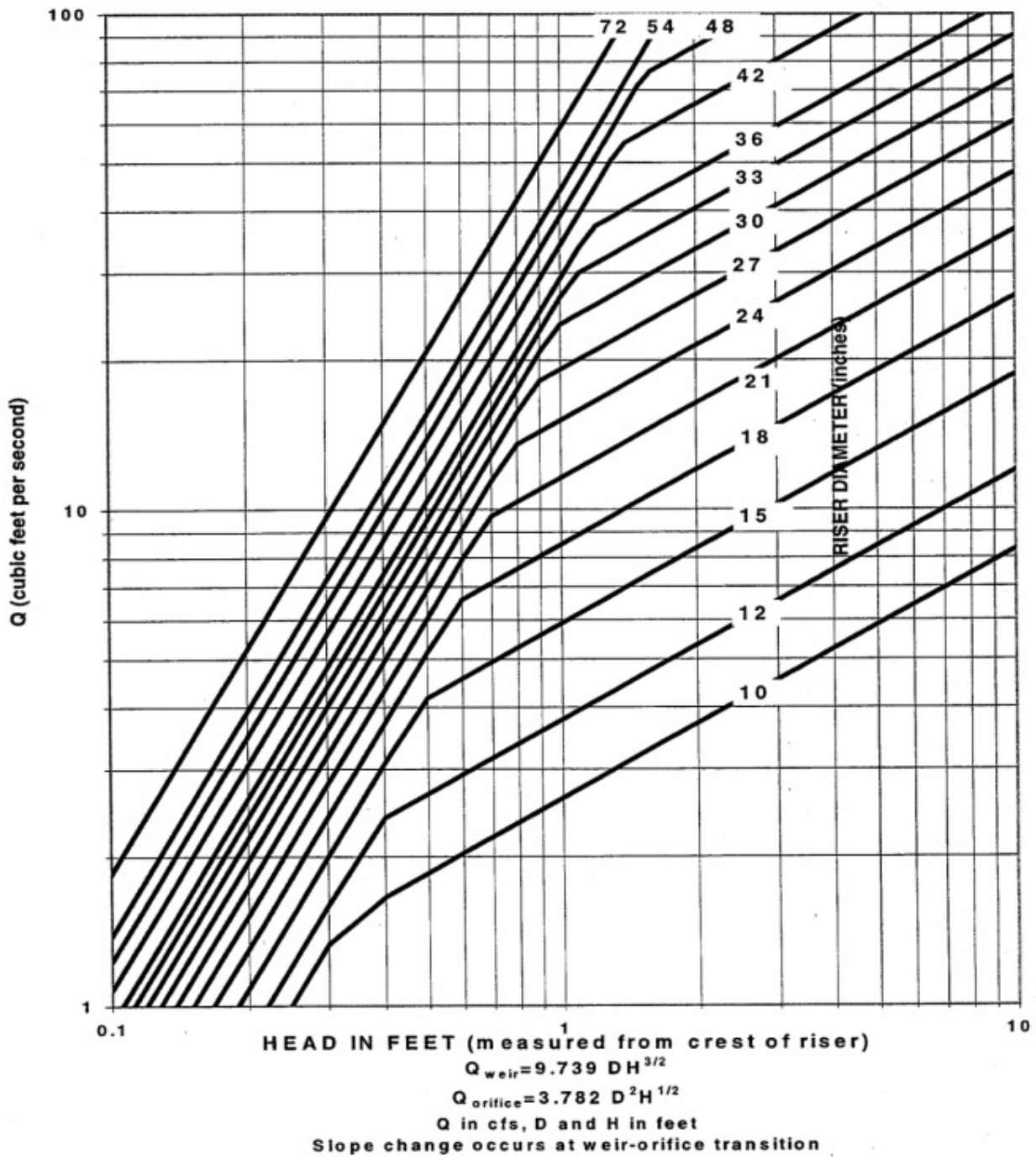

Figure 4.30 Riser inflow chart (from City of Mercer Island, WA)



*The ability of basins to remove sediment varies tremendously (between 50-90%). Performance limitations of sediment basins appears to be caused by two major factors: the extreme difficulty in settling out fine-grained sediment particles in suspension (i.e., fine silts and clays); and the simplistic design of existing basins which fails to create ideal settling conditions over the range of storm events. Indeed, most sediment basins are nothing more than a hole in the ground. Design enhancements such as baffles, multiple cells, stone-wrapped standpipes, skimmers, or other features can increase residence time and improve trapping performance.*

## DEWATERING DEVICES

*Dewatering* is needed when ponding from storms, high groundwater, or other activity occurs in an active construction area. Applications for dewatering include deep excavations, utility installations, shoreline construction, culvert replacement projects, or draining of sediment basins. Dewatering techniques will vary depending on site conditions, but all dewatering discharges require pumping and the filtering of sediment from water prior to discharge. Do not use in lieu of sediment traps or other ESC practices, unless for very small construction jobs such as utility installations. Dewatering devices should be located on site for ease of clean-out, to minimize interference with construction activities, and to avoid erosion at the discharge point.

There are several devices discussed here for dewatering: sump pits, bag filters, weir tanks, and containment areas.

### Minimum Plan Requirements

Details of dewatering practices shall be shown on the plan and contain the following items:

- Location of equipment
- Device type, capacity, pump size/pumping rate
- Installation methodology
- Maintenance and removal requirements, including plan for sediment disposal

### Sump Pits

*Sump Pits* are temporary holes backfilled with a filter media from which excess water is pumped to a stabilized area or other settling practice. Pit dimensions, pumps, and materials are variable, but most designs include a perforated vertical standpipe (or tall bucket) surrounded by gravel or stone. Water is pumped from the center of the pipe and filters through the gravel leaving sediment behind (**Figure 4.31**).

### Design and Installation

1. Pit dimensions are variable, with the minimum diameter being twice the diameter of the standpipe.
2. The standpipe should be constructed by perforating a 12" to 36" diameter pipe. The perforations shall be 1/2" x 6" slits or 1" diameter holes 6" on center.

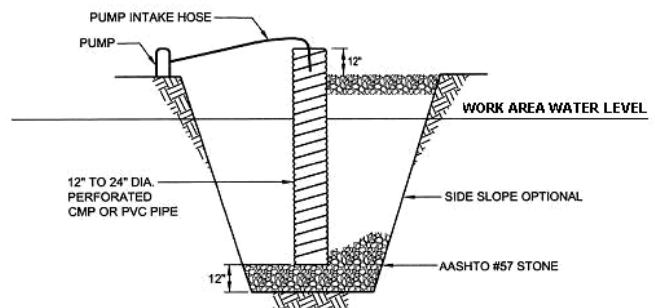

Figure 4.31 Sump pump with perforated standpipe and stone filter.

3. The pipe may be wrapped with 1/2" hardware cloth and geotextile (Class E), depending on use. Be careful of fabric clogging.
4. A base of filter material consisting of washed gravel (minimal fines) or #57 stone (1 1/2" maximum diameter) should be placed in the pit to a depth of 12".
5. After installing the standpipe, the pit surrounding the standpipe should then be backfilled with the same filter material. Gravel



surrounding standpipe should be a minimum thickness of 12 inches.

6. The standpipe should extend 12" to 18" above the lip of the pit (or riser crest elevation for sediment basin dewatering). Filter material should extend 3" minimum above the anticipated standing water level.
7. The hose and pump should be sized based on expected volumes and flow rates. All connections should be watertight.
8. The hose should discharge clean water non-erosively to a stabilized area.
9. If the discharge is still dirty, flows should be direct flow to another sediment trapping device.

### Maintenance

- Inspect and monitor on an hourly basis while pumps are running. Make sure that hose discharges are not causing additional erosion or sedimentation.
- If discharge water is still turbid, verify that the appropriate pump size and device dimensions are being used. If needed, enlarge gravel thickness around standpipe and/or add another trapping or filtering practice at the discharge point and remove accumulated sediment.
- Sump pits must be removed and reconstructed when pump runs dry.

### Troubleshooting

- Unlike other dewatering methods, the effectiveness of the sump pit is dependent on the pump. If mechanical issues are encountered with the pump, they will limit the effectiveness of the sump pit. Also, over time sump pits may become clogged.
- Discharge still turbid. Use the appropriate pump size and device dimensions. Add another trapping or filtering practice. Remove accumulated sediment.
- Sump pit not filtering. Consider wrapping perforated pipe in filter fabric but be careful as this could clog.

### Bag Filter

Bag filters are rectangular sacks made of non-woven geotextile fabric that trap sand, silt, and fines inside while water filters out through the fabric (**Figure 4.32**).

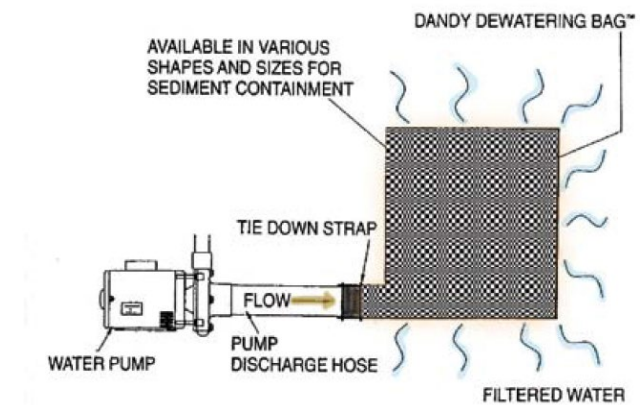

Figure 4.32 Example bag filter discharging to stabilized containment area and detail.

### Design and Installation

There are a variety of manufactured products available, and bags come in different sizes. Follow the manufacturer's instructions for design and installation.

1. Pumping rates will vary depending on the size of the bag and the amount (and type) of sediment discharged to the bag. The pumping rate should be no more than 750 gpm or 1/2 the maximum specified by the manufacturer, whichever is less.
2. Pump intakes should be floating and screened.
3. Filter bags shall be made from non-woven geotextile material sewn with high strength, double stitched "J" type seams and be capable of trapping particles larger than 150 microns.
4. Bag filters should be secured at the end of the pump discharge hose with clamps, straps, or other mechanism.
5. Position bag on a fully grassed area, stone pad, or other stabilized surface. Where this is not

possible, a geotextile or other protected flow path shall be provided.

6. Do not place bags on slopes greater than 5%.
7. Provide a suitable means of accessing the bag with machinery required for disposal purposes.

### Maintenance & Troubleshooting

- Inspect and monitor on an hourly basis while pumps are running. If any problem is detected, stop pumping immediately and do not resume until the problem is corrected.
- Make sure that discharges are not causing additional erosion and sedimentation.
- Follow manufacturer's instructions for removing sediment in reusable bag filters, or for determining when bag filters need to be replaced. Filter bags shall be replaced (or cleaned) when they become ½ full. Spare bags shall be kept available on site for replacement.
- Have a plan in place for proper disposal procedures of sediment and used bags.

### Weir Tanks

Weir tanks are compartmental containers that use a series of baffles to trap sediment (**Figure 4.33**). Sediment-laden water is pumped into and through the tanks, flow rates are dissipated, and the sediment settles out within the baffle system. Weir tanks are ideal for situations where space for dewatering is limited.

### Design and Installation

1. A sediment tank must be sized (and operated) to allow pumped water to flow through the filtering device without overtopping the structure.

Where, Tank Storage (cubic ft) = the pump discharge (GPM) x 16, assuming 2 hours of residence time.

2. Tanks should not be used in lieu of sediment traps or other ESC practices, unless for very small construction projects such as utility installations or in instances in tight urban settings where space is limited.
3. One drawback of weir tanks is that they can be hard to procure on island, or expensive to purchase or rent.



*Weir tanks are divided into compartments by baffles or weir walls that trap sediment. The longer the residence time provided, the cleaner the discharge water will be.*

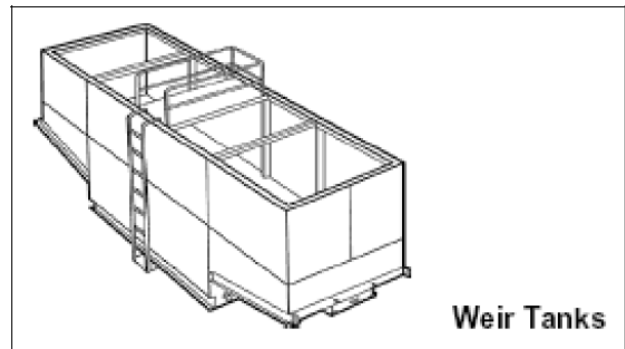

*Figure 4.33 Weir Tank (from TSDM Manual)*

### Maintenance

- Follow manufacturer's maintenance instructions.
- Inspect and monitor on an hourly basis while pumps are running
- Ensure final discharge is not causing additional erosion and sedimentation
- Have a plan for proper disposal of sediment.

### Troubleshooting

Weir tank floods or fills with sediment. Check the tank sizing based on the expected water and sediment volume. Bring in additional tanks as needed.

## Containment Areas

Containment areas are excavated or raised areas surrounded by gravel, silt fence and/or other sediment barriers used for secondary dewatering treatment. They are designed to contain and immobilize sediment.

### Design

The sizing of a containment area should be based on the flow rate (**Table 4.18**). Example details for the construction of a stone and block and filter sock dewatering containment areas are shown in **Figure 4.34** and **Figure 4.35**, respectively.

Table 4.18 Sizing instructions for containment areas.

Flow Rate (gpm / ft <sup>3</sup> /s)	Required Surface Area (ft <sup>2</sup> )	Length/Width=2:1 (ft / ft)
25 / 0.0565	131.86	16.24 / 8.14
50 / 0.1130	263.82	22.97 / 11.48
100 / 0.2225	527.54	32.48 / 16.24
200 / 0.4450	1055.19	45.93 / 22.97
300 / 0.6674	1582.73	56.27 / 28.12
400 / 0.8899	2110.09	64.96 / 32.48
500 / 1.1124	2637.80	72.64 / 36.32

### Installation

Containment areas should be placed in a location that is out of the way of work activities but accessible for monitoring purposes. Ensure that the pump hose or piping is of sufficient length to reach containment area prior to installation.

### Maintenance

- Containment areas should be monitored frequently during operation. If accumulated sediment clogs the hose or fills containment area, it should be removed.
- Surrounding sediment barrier(s) should be inspected and repaired or replaced, as necessary.
- The pump discharge hose needs to be firmly secured so that all discharge waters are directed into the containment area.



Temporary containment areas for dewatering can be installed above ground using raised barriers with waterproof lining, blocks with gravel beds, etc. They can also serve as secondary containment for sediment bags.

### Troubleshooting

If the water entering the containment area is heavily laden with sediment, the stone along the bottom of the area can become clogged. Since the water may be very turbid, leaks through the sediment barriers of the containment area have the potential to create major ESC issues.

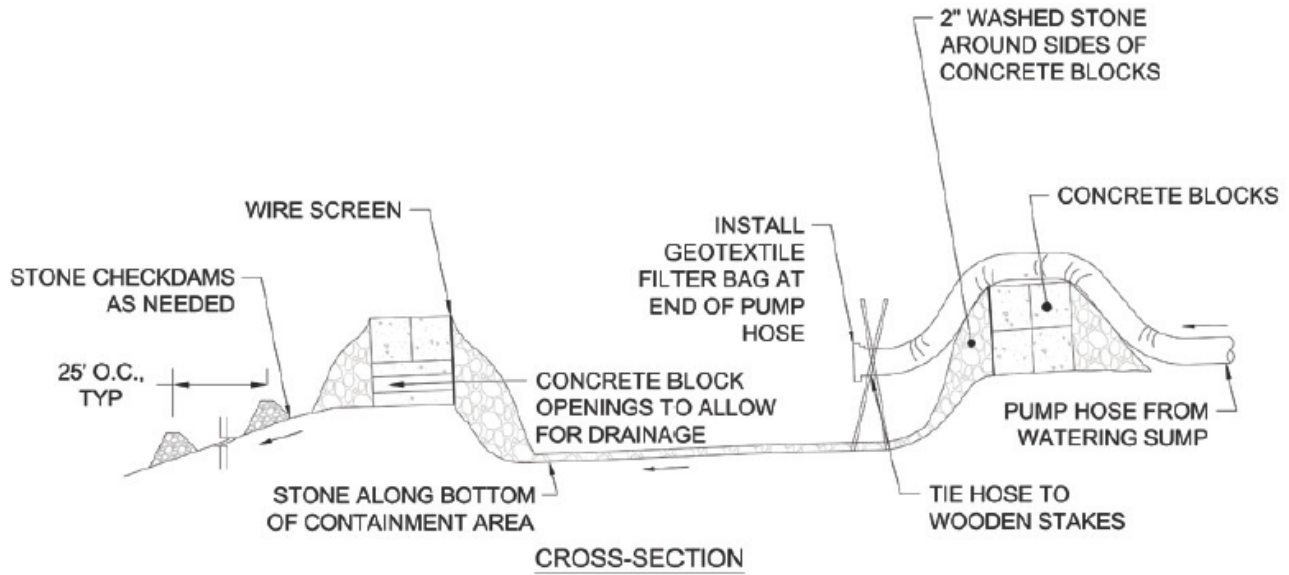

Figure 4.34. Example schematic showing a stone and block dewatering containment area.

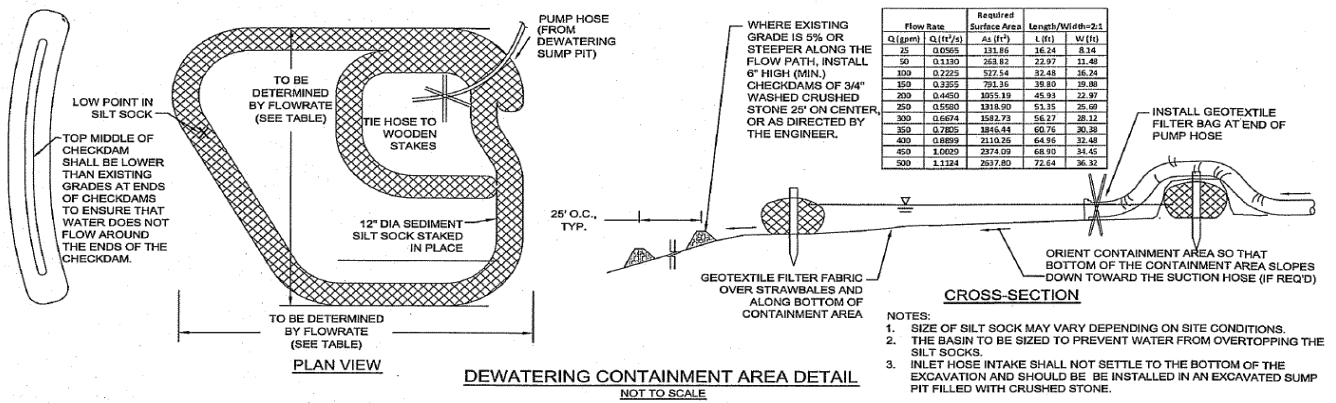

Figure 4.35 Example detail showing a dewatering containment area constructed of compost filter socks.



## 4.5 INLET & OUTLET PROTECTION

This section focuses on the practices used to protect inlets (i.e., catch basins) from sedimentation and outlets (i.e., outfall pipes or discharge locations) from erosion. Inlet and outlet structures are the key locations where concentrated flows enter a piped drainage network or leave the site. Examples of these practices include:

- **Catch basin inserts**—proprietary fabric sacks that are inserted into a grated inlet that collect sediment while letting water pass through. Sacks must be removed and cleaned frequently to avoid ripping or clogging.
- **Drop inlet protection**- includes excavation, filter sock, or stone and block methods used to create a sump or barrier around a drop inlet/catch basin to filter out sediment from runoff before it enters the drainage system.
- **Curb inlet protection**—options for filtering out sediment from a curb inlet can include filter sock, stone, and other materials.
- **Rock outlet protection**—stone or other mechanism to provide energy dissipation and erosion protection at a point where concentrated flow is being discharged.
- **Level spreaders**—flat splash pads at a discharge location that convert concentrated flow into sheet flow as a way to slow and distribute drainage.



*Inlet and outlet protection is as much an art as it is a science. You may have to be creative with accessible materials.*

**Table 4.19** selection matrix compares the relative benefits of individual practices. Contact DPNR for determining acceptability of other techniques.

*Table 4.19 Summary of some common inlet and outlet protection practices and their benefits.*

Benefit	Inserts	Excavated Inlet	Stone and Block Inlet	Curb Inlet Protection	Rock Outlet Protection	Level Spreaders
Effective for trapping sediment	●	●	●	●		
Easy to Install	●	●	●	●	●	
Inexpensive		●	●	●	●	
Handles Large Drainage Areas					●	●
Reduces Velocities/Erosion					●	●
Converts to post-construction					●	●
Low Safety Issues					●	●
Low Maintenance					●	●

## INLET PROTECTION DEVICES

Inlet protection includes the practices used to keep sediment and debris from entering the stormwater drainage pipe system(s) near a construction site. Various devices and materials can be used as a permeable barrier around an inlet. Practices should trap the sediment while allowing water to slowly flow over or through the materials into inlet. Localized flooding may occur if improper protection devices are used, or inlets are allowed to clog. Inlet protection should be used in combination with other ESC practices at the site to provide more effective sediment removal.

There are four basic types of inlet protection described here:

- Manufactured **catch basin inserts** with collection sacks
- **Filter socks** for drop or curb inlet protection
- **Excavated protection** for drop or yard inlets
- **Stone/block protections** for both curb and drop inlet protection

### Minimum Plan Requirements

Details of the inlet protection practices shall be shown on the plan and contain the following items:

- Location(s) on and off site
- Material type and size
- Installation methodology
- Maintenance and removal requirements

### Design

Protection practices should be used where:

- A portion of the drainage area to an inlet is disturbed;
- Inlets on connecting roads may receive sediment via site runoff;
- Permanent stormwater infrastructure will be in use before final site stabilization; and
- Watertight blocking of inlets is not advisable.

Inlet protection devices should NOT be used in lieu of other erosion and sediment control practices elsewhere at the site. The type of practice used will depend on site conditions and the size of the drainage area. Filter socks can be used for inlet protection when

**Warning!** *Inlet protection devices should not completely block flow from entering the inlet structure or else flooding may occur.*



(TOP) Good example of a filter sock inlet protection used on pavement that filters sediment while still allowing drainage.

stormwater flows are relatively small with low velocities and for areas that are already paved, if there is good continuous contact between the sock and the pavement. Stone and block filters can be used where velocities are higher. Straw bales are NOT recommended.

Regardless of the type or materials used for inlet protection, drainage areas should be no larger than one acre per inlet device. The top elevations of these practices should provide storage while allowing for in flow.

The following design guidance is provided for specific types of inlet protection structures.

### Catch Basin Inserts

Specific design and installation steps for these products vary and are provided by the manufacturer (**Figure 4.36**). Generally, the product must be sized to fit the grate and depth dimensions of the existing inlet structure and type of equipment available for removal. Have several replacements on hand.

### Filter Sock Inlet Protection

Filter socks can be used to protect yard, drop, and curb inlets (**Figure 4.37**). This approach is especially well suited for paved areas. Follow manufacturer's design specifications and installation instructions. Fill materials can be disbursed onsite at project completion.

## Excavated Drop Inlet Protection

1. Excavated side slopes of 2:1 or flatter.
2. Depth should be between 1 to 2 feet as measured from top of inlet.
3. Provide weep holes, protected by fabric and/or rock, to drain temporary pool (**Figure 4.38**).
4. Shape the excavated basin to fit conditions with the longest dimension oriented toward the longest inflow area to maximize trap efficiency.
5. The excavated basin's capacity should be sufficient to hold 900 cu ft of runoff per acre of disturbed area.

## Stone and Block Drop Inlet Protection

1. The stone barrier should have a minimum height of 1 foot and a maximum height of 2 feet. Height needs to be limited to prevent excess ponding and flow bypass.
2. Do not use mortar.
3. Recess the first course of blocks at least 2 inches below the crest opening of the storm drain for lateral support. Subsequent courses can be supported laterally, if needed, by placing a 2x4-inch wood stud through the block openings perpendicular to the course. The bottom row of block openings should be oriented for de-watering (**Figure 4.39**).
4. Use  $\frac{1}{2}$ " -  $\frac{3}{4}$ " diameter clean stone or gravel placed 2 inches below the top of the block on a 2:1 slope or flatter. Use hardware cloth or  $\frac{1}{2}$ -inch wire mesh over all block openings to secure stone in place.
5. As an optional design, the "doughnut", concrete blocks may be omitted, and the entire structure constructed of stone ringing the outlet. The stone should be kept at a 3:1 slope toward the inlet to keep it from being washed into the inlet. A level area between the stone and the inlet that is 1 foot wide and 4 inches below the crest will prevent further wash.
6. Stone on the slope toward the inlet should be at least 3 inches in size for stability and 1 inch or smaller away from the inlet to control flow rate.
7. The elevation at the top of the stone crest must be maintained 6 inches lower than the ground elevation downslope from the inlet. This will ensure runoff flows into the structure. Use temporary diking as necessary to prevent bypass.

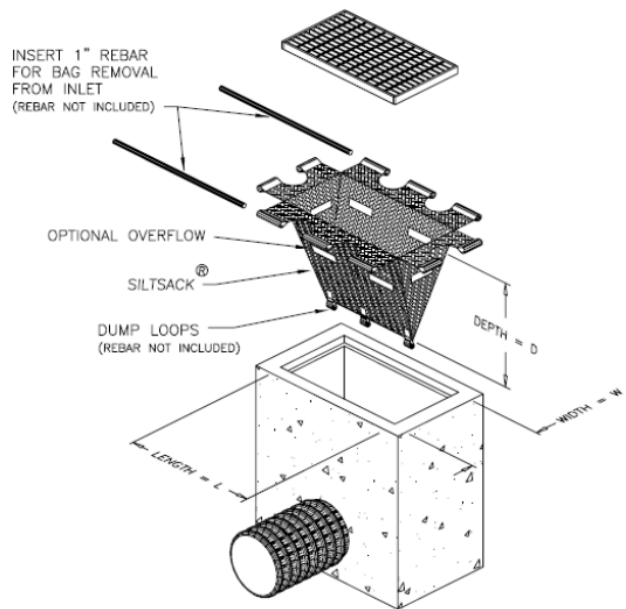
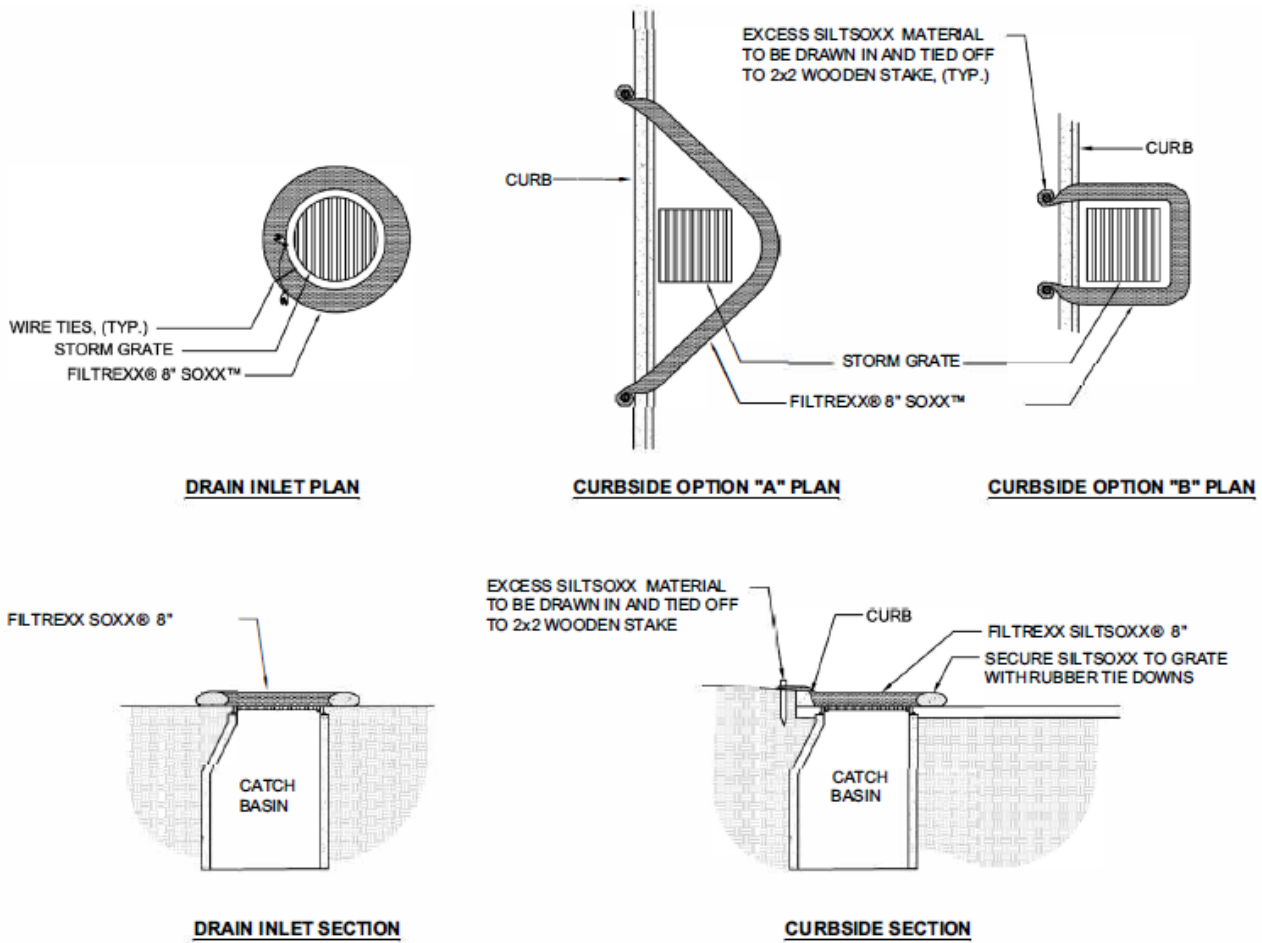

Figure 4.36 Silt Sack™ Catchbasin Protection Detail

## Rock Curb Inlet Protection

1. Wire mesh must be of sufficient strength to support the filter fabric and stone with runoff water fully impounded against it (**Figure 4.40**).
2. Stone shall be 2 inches in size and clean.
3. The filter fabric must be of a type designed for this purpose (see manufacturer's specifications) with an EOS of 40-85.
4. Use a protective wooden frame of 2x4-inch construction grade lumber sized so that it extends 2 feet beyond the inlet in both directions. May be able to use blocks instead of the wooden frame depending on dimensions.
5. Use temporary dikes directing flow to the inlet to prevent bypassing (if applicable).



- NOTES:**
1. ALL MATERIAL TO MEET FILTREXX® SPECIFICATIONS.
  2. FILTER MEDIA™ FILL TO MEET APPLICATION REQUIREMENTS.
  3. COMPOST MATERIAL TO BE DISPERSED ON SITE, AS DETERMINED BY ENGINEER.

## FILTREXX® INLET PROTECTION

NTS



Figure 4.37 Several drain and curbside options for using filter socks for inlet protection (from Filtrexx)



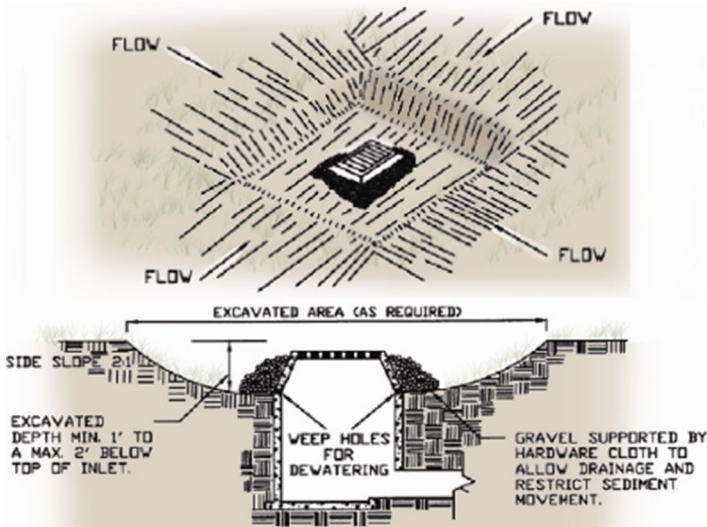

Figure 4.38 Schematic drawing of an excavated drop inlet protection with weep holes.

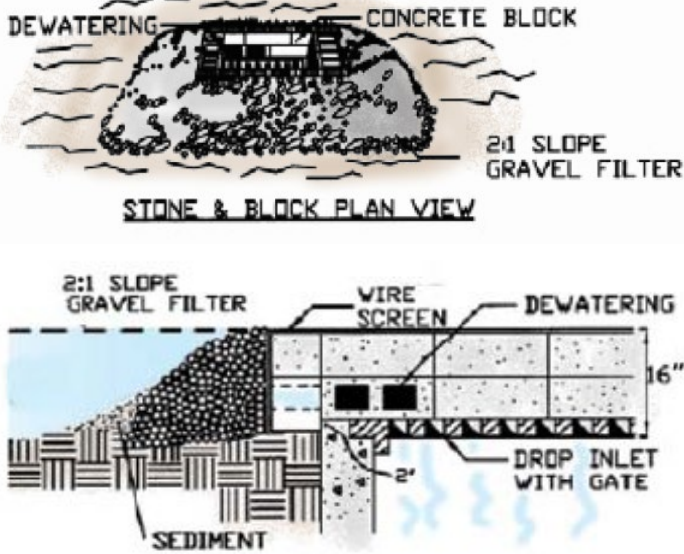

Figure 4.39 Schematic drawing of stone and block drop inlet protection showing dewatering holes. .

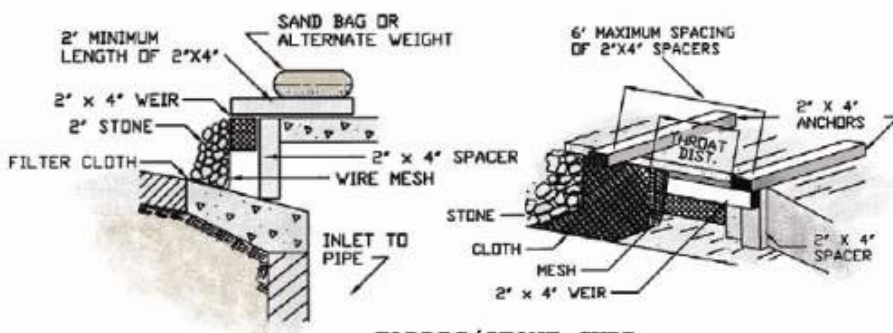

Figure 4.40 Schematic drawing of rock curb inlet protection and examples of using concrete blocks for curbside inlets. .



*(LEFT) No inlet protection measures installed allows sediments and construction debris to enter drainage pipes prior to site stabilization. (RIGHT) A creative use of temporary wire mesh and geotextile for inlet protection.*



*Impermeable sandbags used to protect inlets can lead to localized flooding if the weir elevations are too high or placement prevents any spillover. (Left) Sandbag elevation is lower than roadway and sediment is trapped in paved ditch. (Right) Sandbags do not block curb inlet allowing for passage of high flows into the drainpipe.*



*(LEFT) This product is not suited for this type of inlet structure, since "dirty" flows enter drain directly through the grated opening. (RIGHT) An alternative product may be more appropriate.*

## Installation

All inlet protection devices should be installed according to the specifications in site plan or the manufacturer's instructions. These practices should be installed before any soil disturbance takes place in the inlet drainage area and should remain in place until the area has permanently stabilized. The following guidance is provided for specific types of inlet protection structures:

### Excavated Drop Inlet Protection

1. Clear the area of all debris that will hinder excavation.
2. Grade the approach to the inlet uniformly around the basin.
3. Ensure weep holes are fully protected with filter fabric and stone.
4. Once of contributing drainage area is permanently stabilized, seal weep holes, fill basin with stable soil to final grade, compact it properly, and stabilize with permanent seeding.

### Block and Rock Drop Inlet Protection

1. On each side of the inlet structure, lay a block on its open side for de-watering. Cover openings with hardware cloth or wire mesh to support rock.
2. Build a foundation 2 inches (minimum) below the crest of the inlet and place blocks against the inlet for support.
3. Place the hardware cloth or ½-inch wire mesh over block openings to support the stone.
4. For the "doughnut" design, a 1-ft thick layer of the smaller filter stone should be placed against the 3-inch stone.
5. Upon stabilization of the contributing drainage area, remove all materials and any unstable soil and dispose of them properly.
6. Bring the disturbed area to proper grade; smooth, compact, and stabilize the land in a manner appropriate to the site.

### Curb Inlet Protection

1. Install prefabricated products in front of the curb inlet opening, extending 2 feet on either side. Allow for overflows at the top into the catch basin. Follow manufacturer's specifications.
2. For block and rock curb inlet protection, place single row of concrete blocks across inlet opening

with open ends facing outward. Place wire mesh over open ends of blocks to support rocks. Pile washed rock (<3-inch diameter) against mesh to top of blocks.

3. For wire and rock protection (see Figure 4.40), the wire mesh across throat shall be a continuous piece, 30-in minimum width and 4 ft longer than the throat. Shape mesh and nail securely to a 2x4-in weir. Securely nail the weir to 2x4-in spacers 9 inches long and spaced no more than 6 ft apart. Place the assembly against the inlet and secure it with 2x4-in anchors 2 ft long, extending across the top of the inlet and held in place by sandbags or alternate weights. Pile the clean rock against the mesh.

After permanent stabilization of the site, remove all materials and sediment and dispose of properly. Seal any temporary weep holes, and bring adjacent areas to final grade, ensuring that the inlets are the lowest point in the immediate area to prevent ponding/flooding issues.

## Maintenance

- Inspect the devices after each rain event and make repairs, such as removing sediment and replacing any missing stone, as needed
- Fabric inserts will need to be checked regularly and replaced if ripped.
- Check materials for proper anchorage and secure them, as necessary.
- If sediment is accumulating outside of the inlet protection device, remove the sediment when the storage area is half full.

## Troubleshooting

- The wrong type of inlet protection is selected for a given inlet and the inlet is not protected from receiving dirty water. Redesign inlet protection structure to meet site-specific needs.
- If sediment is entering the inlet, verify that the inlet protection structure has been installed correctly and that upstream soil is stabilized, and upstream ESC practices are installed.
- The rock filter material of the inlet control system gets clogged. Pull rocks away from the inlet, clean out excess sediment and debris, and replace the rocks with new or washed rocks.
- Sediment accumulating outside of the inlet protection device. Sediment should be removed when the structure is ½ full.

## OUTLET PROTECTION

Outlet protection includes structures used around discharge pipes or other outlets to prevent scour and erosion from concentrated discharges. Some outfalls and culverts are constructed with concrete headwalls, aprons, and energy dissipators. For temporary or less formal settings, rip rap and geotextile may be the most cost-effective protection measure. Two common types of outlet protection are discussed here: rock outlet protection and level spreaders.

Outlet protection should be installed during initial construction activities and be used where concentrated discharge may result in scour holes, gullies, or the undermining of roads and structures. Runoff discharged at an outlet should not contain sediment if other ESC measures are working properly throughout the site. As such, outlet protections are not designed for sediment trapping, rather, they are designed to stabilize discharge points and to slow flows.

### Rock Outlet Protection

Placement of crushed stone or rip rap around and below a pipe or channel outlet in an extended apron to prevent scour and protect embankments. Stone diameter and apron length are based on volume and velocity of flow (**Figure 4.41**). The flows are slowed down and spread out by the crushed stone. Do not use for outlets on slopes steeper than 10% because flows will quickly reconcentrate and scour below the apron. For these applications use a lined waterway.

### Minimum Plan Requirements

Details of the rock outlet protection practices shall be shown on the plan and contain the following items:

- Location(s) on site
- Apron Dimensions
- Rock type and size
- Type of filter layer
- Installation methodology
- Maintenance requirements

### Design

Design depends on tailwater depth, apron size, bottom grade, alignment, materials, thickness, stone quality, and filter for this practice. Contact DPNR's Division of Environmental Protection or a licensed engineer for assistance with design.



*Rock outlet protection for discharge pipes without a headwall.*

1. Examine the downstream channel to assure that non-erosive velocities can be maintained.
2. **Tailwater:** Determine the depth of tailwater immediately below the pipe outlet based on design capacity of the pipe. If the tailwater depth is less than half the diameter of the outlet pipe and the receiving stream is wide enough to accept divergence of the flow, it shall be classified as a *Minimum Tailwater Condition* (see **Figure 4.43**). If the tailwater depth is greater than half the pipe diameter and the receiving stream will continue to confine the flow, it is classified as a *Maximum Tailwater Condition* (see **Figure 4.44**). Assume pipe outlets on flat areas with no defined channel have Minimum Tailwater Condition.
3. **Apron Sizing:** Determine the apron length and width (upstream and downstream) using the curves shown in **Figure 4.43** and **Figure 4.44** according to the tailwater conditions. If the pipe discharges directly into a well-defined channel, the apron shall extend across the channel bottom and up the banks to an elevation that is one foot above the maximum tailwater depth or to the top of the bank, whichever is less. The upstream end of the apron, adjacent to the pipe shall have a width that is twice the diameter of the outlet pipe, or conform to pipe end section, if used.
4. **Slope:** Construct the outlet protection apron with no slope along its length. There shall be no overfall at the end of the apron. The elevation of the downstream end of the apron shall be equal to the elevation of the receiving channel or adjacent ground.

An alternative to the apron design is use of a *plunge pool* at the end of an outlet, which could offer an option for slopes <10% (see **Figure 4.42**).

5. **Alignment:** Locate the rock apron so that there are no bends in the horizontal alignment.
6. **Material:** The apron can be constructed with rock rip-rap, grouted rip-rap, or gabions. Rip-rap shall be composed of a well-graded mixture of stone size so that 50 percent of the pieces, by weight, shall be larger than the d50 size determined by using the charts. (A well-graded mixture is defined as a mixture consisting mainly of larger stone sizes but with a sufficient mixture of other sizes to fill the smaller voids between the stones.) The diameter of the largest stone size in the mixture shall be 1.5 x the d50 size.

If using field stone or rough un-hewn quarry stone for rip-rap, the stone shall be hard and angular and of a quality that will not disintegrate on exposure to water or weathering. The specific gravity of the individual stones shall be at least 2.5. Recycled concrete equivalent may be used provided it has a density of at least 150 pounds per cubic foot and does not have any exposed steel or reinforcing bars.

6. **Layer Thickness:** The minimum thickness of the rip-rap layer shall be 1.5 x the maximum stone diameter for d50 of  $\leq 15$  inches; and 1.2 times the maximum stone size for d50 of  $> 15$  inches (**Table 4.20**).
7. **Filter Layer:** Place a filter layer under rip-rap in all cases. A filter can be either a gravel layer or filter cloth. Use filter cloth made of either woven or non-woven monofilament yarns with 20-60 mil thickness and 90-120 pound grab strength. If gravel filter blanket is used, design it by comparing particle sizes of the overlying material and base material.

If using *gabions*, they shall be made of hexagonal, triple-twist mesh with heavily galvanized steel wire. The maximum linear dimension of the mesh opening shall not exceed 4½ inches, and the area of the mesh opening shall not exceed 10 square inches. Construct gabions so that the sides, ends, and lid can be assembled at the construction site into a rectangular basket of the specified sizes. Grade the area on which the gabion is to be installed as shown on the drawings. Use the same foundation conditions as for placing

rock rip-rap and place filter cloth under all gabions. A key may be needed to prevent undermining of the main gabion structure.

*Table 4.20 Minimum blanket thickness and stone sizes (Empire State Chapter Soil & Water Conservation Society,*

D50 (inches)	dmax (inches)	Minimum Blanket Thickness (inches)
4	6	9
6	9	14
9	14	20
12	18	27
15	22	32
18	27	32
21	32	38
24	36	43



*Concentrated flows at the end of a discharge pipe can cause erosion and scour if the outlet is not stabilized or flow velocities are too high.*

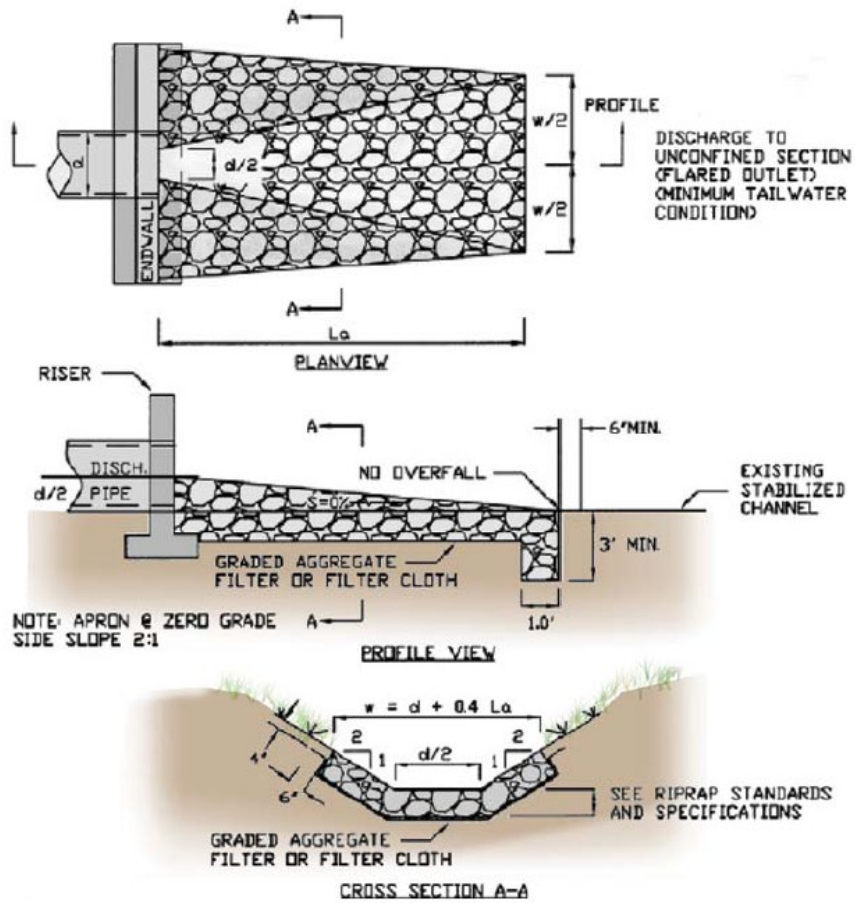

Figure 4.41 Example 1. Rip rap outlet protection structure for discharge to an unconfined section.

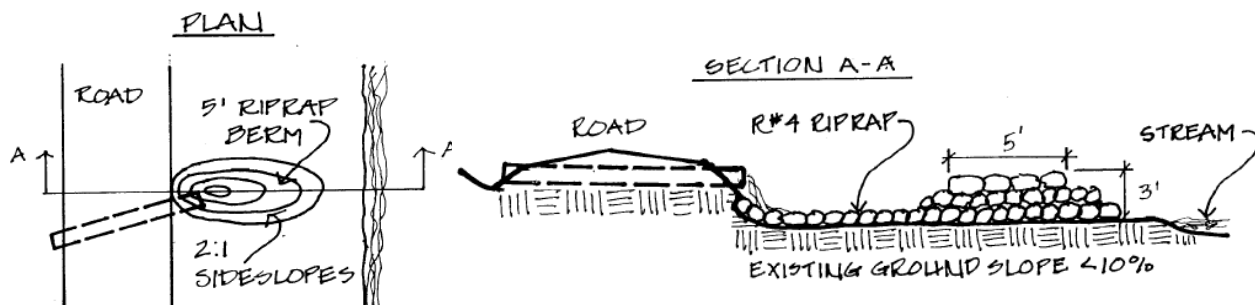

Figure 4.42 Plunge pool design for outlet protection to prevent erosion at the discharge location or on a side slope (Source: VT Unpaved Road BMP Manual).

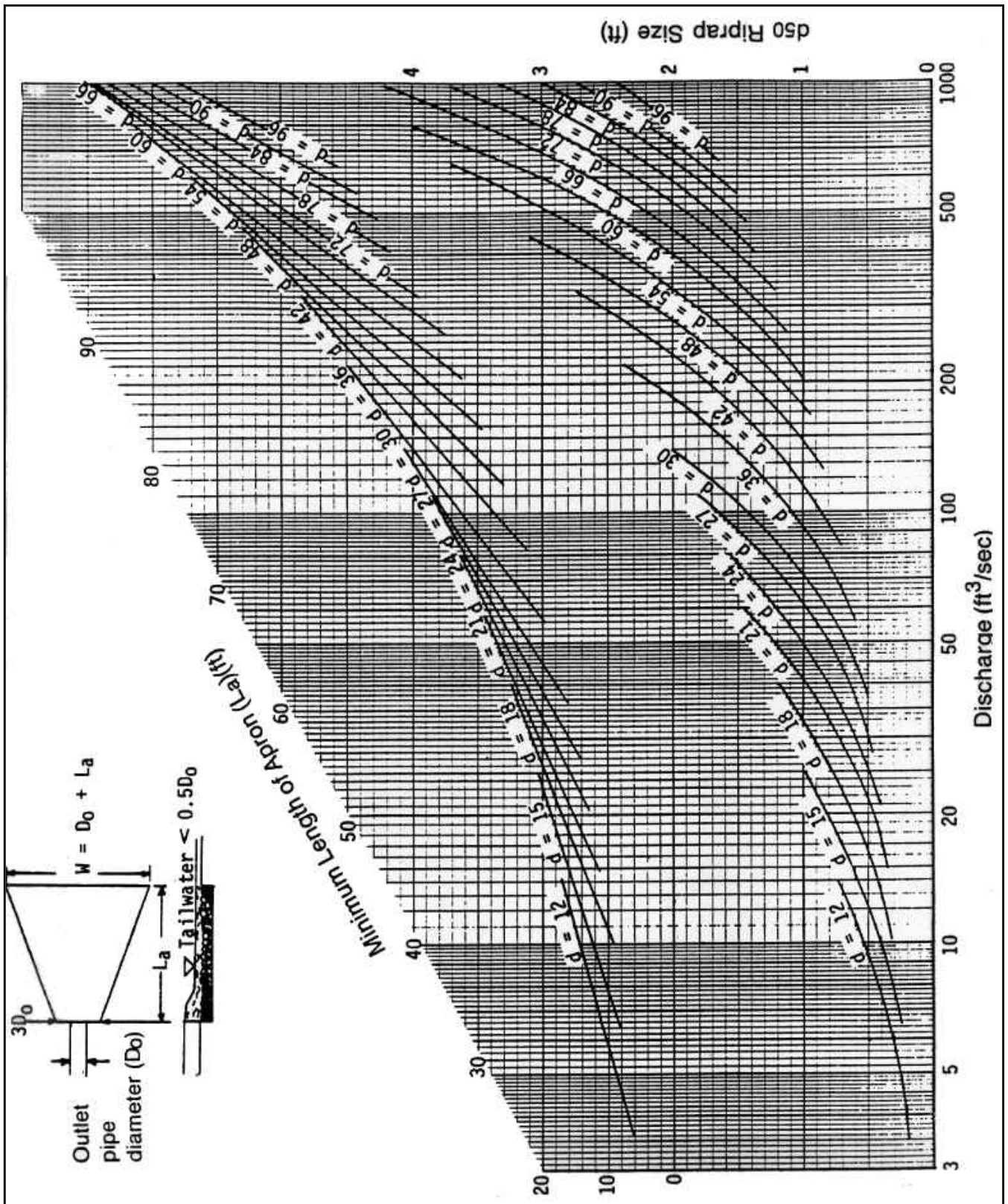

Figure 4.43 Minimum Tailwater Condition—design of outlet protection from a round pipe flowing full, minimum tailwater condition:  $T_w < 0.5D_o$  (Empire State Chapter Soil & Water Conservation Society, 1991).

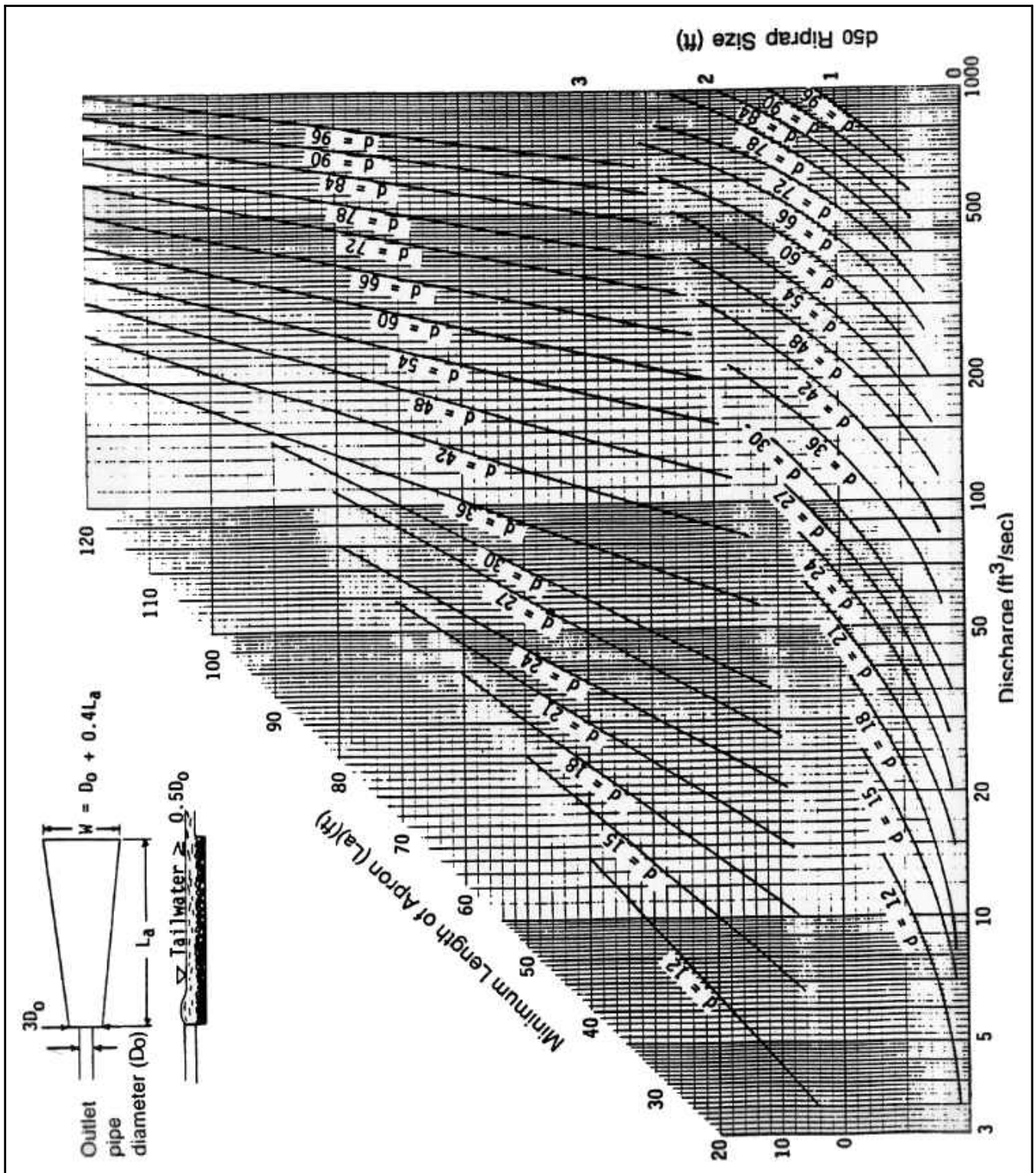

Figure 4.44 Maximum Tailwater Condition—design of outlet protection from a round pipe flowing full, Maximum tailwater condition:  $T_w > 0.5D_0$  (Empire State Chapter Soil & Water Conservation Society, 1991).



## Installation

When installing rock outlet protection, follow specifications from approved drawings. The following are general guidelines for installing an outlet protection structure:

1. Prepare subgrade as specified. Compact fill to density similar to surrounding material.
2. Outlet aprons should be straight and flat. The end of the apron should be at the same elevation as the receiving channel or ground.
3. Use rock riprap composed of a well graded mixture of rock size specified in the ESC plan.
4. Apply layer of approved filter material between the rip-rap and underlying soil surface. Protect filter cloth from punching, cutting or tearing. Repair any damage other than occasional small holes by placing another piece of cloth over the damaged part or by completely replacing the cloth. All overlaps, whether for repairs of joining two pieces, shall be a minimum of 1 foot.
5. Place rock with equipment to full thickness in one operation to avoid the displacement of, or damage to, the underlying material. Follow with hand placement when necessary.
6. Deliver and place the stone for rip-rap or gabion outlets so that stone size distribution is relatively even, with the smaller stones filling the spaces between the larger stones.
7. Place rock around and above outlets with no headwalls.

## Maintenance

Once a riprap outlet has been installed, the maintenance needs are very low. It should be inspected after high flows for evidence of scour beneath the riprap or for dislodged rocks. Repairs should be made immediately.

## Troubleshooting

- High flows can quickly cause scour. Replace filter fabric and rearrange rock appropriately.
- Rip-rap can become dislodged. Reposition or replace rocks by hand.
- Filter cloth gets ripped. Cover with another piece of cloth or replace.
- Rip-rap becomes filled with sediment. Evaluate upstream ESC practices. Remove sediment by hand.



(Top) Outfall with no protection. (Middle) Outfall with some stone and vetiver. Stone should wrap fully around the pipe. (Bottom) Concrete headwall and energy dissipators at outfall location on a slope.

## Example Calculations

**Example 1:** Pipe flow (full) with discharge to unconfined section (**Figure 4.41**).

Given: A circular conduit flowing full.

$$Q = 280 \text{ cfs}$$

$$\text{Diameter (Do)} = 66 \text{ inches (5.5 ft)}$$

Tailwater (surface) is 2 feet above pipe invert ( $< 0.5D_o$  = minimum tailwater condition – use **Figure 4.43** curves).

Find: Read from **Figure 4.43** at intersection of lower  $d = 66$  inches curve and  $Q = 280$  cfs to find  $d_{50} = 1.2$  ft.

Read at intersection of upper  $d = 66$  inches curve and  $Q = 280$  cfs to find apron length ( $L_a$ ) = 38 feet.

Apron width = diameter +  $L_a = 5.5 \text{ ft} + 38 \text{ ft} = 43.5$  feet.

Blanket thickness = For  $d_{50} \leq 15$  inches (from 1.2 ft above), thickness =  $1.5 \times d_{\max}$ .

Use **Table 4.20** to find  $d_{\max} = 22$  inches; blanket thickness = 32 inches.

**Example 2:** Box flow (partial) with high tailwater.

Given: A box conduit discharging under partial flow conditions.

A concrete box 5.5 ft high x 10 ft wide, flowing 5.0 ft deep.

$Q = 600$  cfs and tailwater surface is 5 feet above invert ( $> 0.5 \times$  the culvert depth = maximum tailwater condition – use **Figure 4.44**).

Since this is not full pipe flow and does not directly fit the nomograph assumptions, it is necessary to calculate the velocity in the conduit and then substitute the depth of flow as a diameter to find a discharge equal to full flow for that diameter (flow depth - 5.0ft = 60 inches, and cross-sectional flow area = (5ft x 10ft) = 50sf).

Compute velocity:  $V = Q/A = 600 \text{ cfs} / (50 \text{ ft}^2) = 12$  feet/second (fps)

Then substituting:

$$Q = \frac{\pi D^2}{4} \times V = \frac{3.14 (5 \text{ ft})^2}{4} \times 12 \text{ fps} = 236 \text{ cfs}$$

On **Figure 4.44**, at the intersection of the lower curve  $d = 60$  inches and  $Q = 236$  cfs, read  $d_{50} = 0.4$  feet.

Then reading the upper  $d = 60$  inches curve, read apron length ( $L_a$ ) = 40 feet.

Apron width,  $W =$  conduit width +  $0.4 \times L_a = 10 + 0.4 \times 40 = 26$  feet.

**Example 3:** Open channel flow with discharge to unconfined section

Given: A trapezoidal concrete channel 5 feet wide with 2:1 side slopes is flowing 2 feet deep;  $Q = 180$  cfs and the tailwater surface downstream is 0.8 feet ( $< 0.5 \times$  the culvert depth = minimum tailwater condition –

**Figure 4.43**). The cross-sectional flow area is  $\frac{1}{2}(\text{top width} + \text{bottom width}) \times \text{depth}$  or  $\frac{1}{2}(13+5) \times 2 = 18 \text{ sf}$ .

Thus, velocity is  $Q/A = 180 \text{ cfs} / 18 \text{ sf} = 10$  fps.

Find: Using similar principles as Example 1, compute equivalent discharge for a 2-foot (to match flow depth in channel) circular pipe flowing full at 10 feet/second.

$$Q = \frac{\pi D^2}{4} \times V = \frac{3.14 (2 \text{ ft})^2}{4} \times 10 \text{ fps} = 31.4 \text{ cfs}$$

At the intersection of the lower  $d = 24$  inches curve and  $Q = 32$  cfs, read  $d_{50} = 0.6$  feet. Then reading the upper  $d = 24$  inches curve at  $Q = 32$  cfs, read apron length ( $L_a$ ) = 20 feet. Apron width,  $w =$  bottom width of channel +  $L_a = 5 + 20 = 25$  feet.

## LEVEL SPREADERS

Level spreaders are temporary (or permanent) devices that take concentrated flow from a pipe, berm, or swale and release it evenly over a wider area to prevent erosion and promote infiltration. There are several level spreader designs that differ based on the peak rate of inflow, the duration of use, and the site conditions. All designs follow the same basic principles: water enters the spreader through overland flow, a pipe, ditch or swale; the flow is distributed throughout a long linear shallow trench or behind a low berm; and then water flows over the berm/ditch uniformly along the entire length. Level spreaders can be used during construction or as a part of post-construction stormwater control. They are particularly useful where it is possible for sheet flow discharge across vegetated buffers.

### Minimum Plan Requirements

Details of the level spreader shall be shown on the plan and contain the following items:

- Location(s)
- Length calculations
- Dimensions and materials
- Installation and maintenance methods

### Design

1. The maximum drainage area to a level spreader should be 2.5 acres.
2. A level spreader should disperse onto a vegetated slope that has a gradient of less than 10:1 (H:V).
3. The lip can be constructed of either erosion control matting or grass for low flows, or concrete for higher flows with a minimum 6-inch depression behind the lip **Figure 4.45** and **Figure 4.46**.
4. Stormwater flowing over the lip should be limited to a depth of approximately 6 inches and a velocity of 1 fps or less for the design storm.
5. The level spreader lip shall be constructed with a maximum slope of 0.1% along its length.
6. The length of the level spreader lip depends on the volume of water that must be discharged, but 6 ft is the minimum lip length.
7. Runoff entering a level spreader must not contain significant amounts of sediment. A suite of practices should be used throughout the site to ensure runoff is clean at this outlet practice.

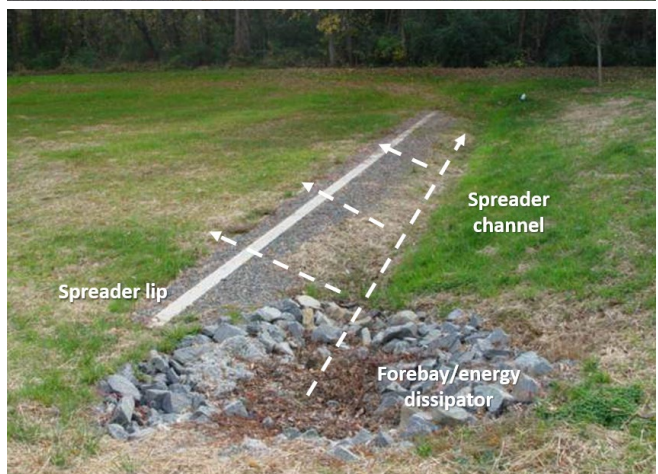

*Example level spreader designs with a concrete spreader lip (top) and channel design (bottom). Both options take concentrated flow from outlet, spread it out, slow it down, and discharge as sheet flow to stabilized area (from NC State).*

### Example Calculation

A level spreader is proposed to disperse the runoff from the 1-year storm event, with a peak discharge rate ( $q$ ) of 5 cfs. Calculate the required length of the level spreader.

$$\text{Length (L)} = \text{peak discharge rate (q)} / [\text{maximum velocity (v)} * \text{depth (d)}]$$
$$L = 5 \text{ cfs} / (1 \text{ fps} * 0.5 \text{ ft}) = 10 \text{ feet}$$

A level spreader with a 10-foot lip is required for this example.

## Installation

Level spreaders need to be constructed carefully to ensure proper gradients. They can be built using earthen or concrete lips, as shown on.

1. Install in an undisturbed or finished area, making sure that the area below level spreader is stabilized and uniform.
2. Do not install on fill, or above a slope steeper than 10%.
3. Spreader lip must be level (uniform height and <math><0.1\%</math> slope).

## Maintenance

- Inspect level spreaders after rain events. Look for signs of erosion below lip and stabilize as needed. Re-evaluate and fix slope of lip or length of level spreader if severe erosion occurs.
- If the filter fabric and/or stone become dislodged, replace filter fabric and reposition and/or add rock.
- Remove sediment when level spreader is half full and investigate the drainage area to find and fix the source of sediment.
- If vegetation becomes established within the level spreader, remove the vegetation by hand.

## Troubleshooting

If level spreaders are not installed completely flat, water can concentrate at one or more points, causing scour. If this happens, remove any sediment build-up,

reset the level spreader at 0% slope, and then stabilize any downstream erosion. If the full suite of ESC measures is functioning properly on site, discharge at the outlet should be relatively sediment-free.

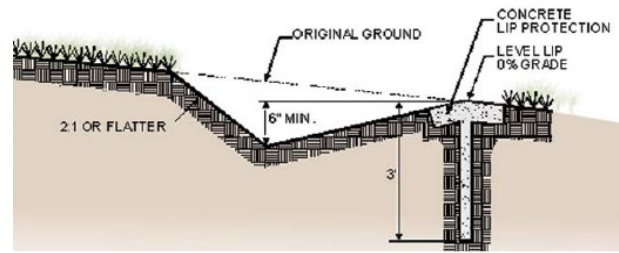

Concrete lip

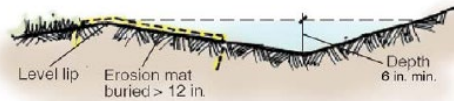

Earthen lip

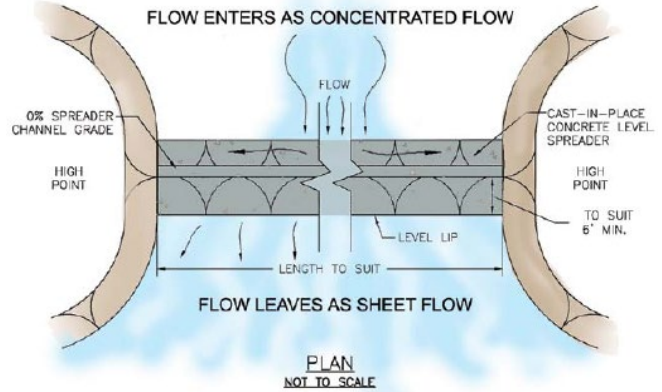

Figure 4.45 Schematic drawings of concrete and earth lipped level spreaders.

<math><6:1</math> Slopes (15%)

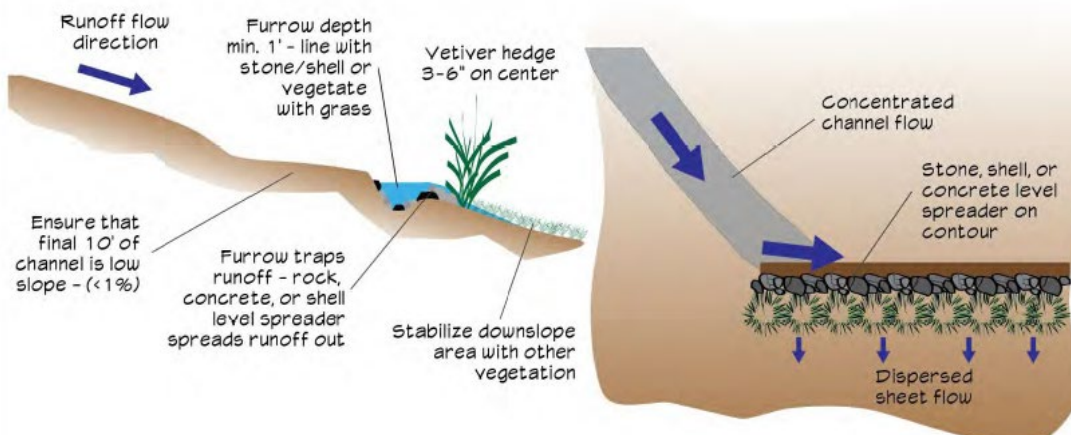
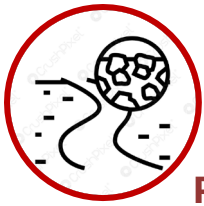

Figure 4.46 Vetiver spreader system detail from Coral Bay Community Council (2017) showing option for converting concentrated flow to sheet flow using rock, shell, or concrete level spreader. Good for turnouts and other flows on slopes of 15% or less.



## 4.6 UNPAVED ROAD PRACTICES

While most roads and driveways in the USVI are required to be paved (impervious or pervious), newly constructed access roads and existing unpaved roads are vulnerable to erosion and can be significant sources of sediment to nearshore waters. In addition to the standard ESC practices described previously in this Chapter, there are several road-specific practices that can reduce the length of time erosive runoff stays on the road, improve the durability of unpaved surfaces, and reduce overall road maintenance needs.

These practices include:

- **Grade breaks**—a rolling hill intentionally inserted into a stretch of road used to break runoff into smaller volumes.
- **Dips**—a short concrete or stone pad used at a low point (ditch or gut crossing) to convey flows safely across the surface from one side of the road to the other.
- **Cross-drains and culverts**—a buried pipe used to convey flows from one side of the road to the other.
- **Waterbars**—narrow berms installed across the road used to break up surface flows by intercepting surface drainage and diverting into a ditch or outlet.
- **Turnouts**—open relief channels in road shoulder used to divert flows away from roadway and into stabilized practices, such as sediment trap.
- **Geosynthetics**—manufactured products integrated into the roadbed or side slopes to hold aggregate and native materials in place to improve durability and longevity of surfacing.
- **Surface stabilizers**—a quasi-concrete mixture or liquid application used to improve adhesion of unpaved surface materials without a commitment to full paving.



*Unpaved roads on steep, highly erodible slopes are one of the most significant sources of sediment to nearshore waters in the USVI. Strategic paving and use of appropriate drainage practices can have a direct impact on the quality of water resources (photo: Coral Bay Community Council).*

**Table 4.21** provides a relative comparison of the benefits of using common unpaved road practices, such as ease of installation, cost, and maintenance burden.

*Table 4.21 Summary of unpaved road drainage practices and their benefits.*

Benefit	Grade Breaks	Dips	Cross Drains & Culverts	Waterbars	Turnouts	Geosynthetics	Surface Stabilizers
Easy to Install	●			●	●		
Inexpensive	●			●	●		
Used in series on slopes			●	●	●	●	●
Used at gut crossings		●	●				
Can be permanent feature	●	●	●	●	●		
Doesn't require a ditch	●			●		●	●
Manages long road segments	●			●		●	●
Low maintenance	●	●				●	●
Low impact on drivers	●		●		●	●	●



All unpaved roads will require maintenance, regardless of the presence or effectiveness of drainage SCMs. The application of good road design and drainage practices may reduce the frequency of maintenance. Ultimately, most roads should be paved with concrete or other stable surfacing and include proper stormwater infrastructure (top photos courtesy of CBCC).



## GRADE BREAKS

Grade breaks are subtle grade changes that redirect flows off the road surface (to one or both sides). Their purpose is to shed water to the shoulders, even where road crown or pitch has been lost, without drivers noticing. Grade breaks are not intended carry concentrated flow and are effective on moderately to low sloped roads. If properly executed, breaks go unnoticed by drivers and are an inexpensive design option that can minimize the number of other drainage control practices needed.

### Minimum Plan Requirements

Grade breaks should be shown on the grading plan and longitudinal road profile with elevations. A road cross-section should be provided for each break. Maintenance plans should provide instructions on how to maintain the elevation of the break over time.

### Design

1. Grade breaks should be incorporated during the early stages of road design so they can be created during initial road construction. They should be big enough to shed water, but gentle enough to allow traffic passage.
2. Space as needed based on slope; should be less than 10% slope.
3. Use longer transitions on steeper slopes to tie grade break into existing road elevation.
4. Can be used in conjunction with cross drains to provide needed pipe cover (**Figure 4.47**).

### Installation

1. Easy to install with commonly used machinery (e.g., bulldozer or grader).
2. Could require 40 to 60 tons of material to create transitions into and out of a grade break.
3. Taper edges of grade break back into road grade. Test by driving across it. If you bottom out, the break grade is not subtle enough.



*High points in the road help shed surface runoff without a noticeable impact on drivers.*

### Maintenance

Grade breaks are relatively maintenance free but can be easily lost during routine road regrading. Consider installing signage or marker to alert maintenance crews to location of grade break. Instruct operators not to use grade break as source of material to smooth other road deformities.

### Troubleshooting

- If vehicles bottom out on top of grade break, lower grade and/or extend the transition slope.
- Erosion or scour occurs at base of break may indicate that the uphill transition slope needs to be elongated. Alternatively, additional turnouts or cross drains may reduce flow volume.
- Avoid the loss of grade break shape overtime. Include profiles in the maintenance plan.

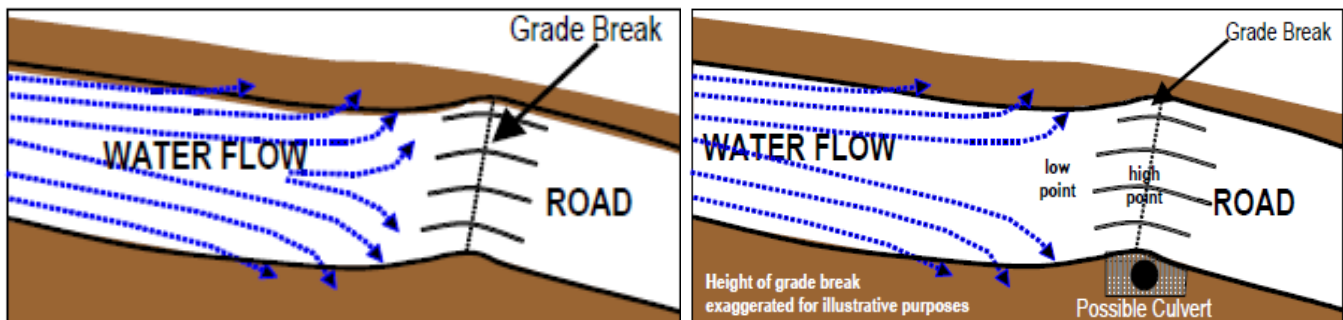

Figure 4.47 Diagram of grade breaks with and without cross drain (graphic from: Center for Dirt and Gravel Road Studies).

## BROAD-BASED DIPS

A dip is a wide, shallow, reinforced depression designed to intercept surface runoff, ditch drainage, or gut flows and convey discharge safely across the road. Dips are located at low points, have gentle side slopes to allow for vehicles to pass without jarring, are designed to convey the anticipated volume of flow, and have a stabilized outlet to spread and dissipate discharge. Broad-based dips, rolling dips, and low water crossing design variants made with slightly different shape, widths, or materials based on function (**Figure 4.48** through **Figure 4.52**). Some low water crossings can accommodate subsurface flows.

### Minimum Plan Requirements

- Location(s) on site
- Details showing dimensions, materials, and outlet protection devices
- Flow calculations and associated guts (if any)
- Installation schedule and maintenance plan

### Design

1. Requires a wide depression, sometimes combined with a downhill berm or swale. If gut flow is intercepted, dip width should be wider than the gut channel bottom.
2. Sizing will vary depending on road slope and traffic volume. Dips on flat roads may be relatively small (fill transitions as short as 12 ft and as low as 6 inches). Dips on steeper roads will require more "approach fill" (fill transitions >100 ft long and up to 18 inches deep).
3. The general spacing of multiple dips can be based on slope (**Table 4.22**), but these are often sited at the existing low points. Other practices can be used to reduce the size of the drainage area contributing to a dip, if necessary.
4. Fully extend width to both edges of road. Skew at 20–40-degree angle to promote self-flushing.
5. Provide a 2- 3% elevation drop towards outlet.
6. Reinforce bottom of dip with 3-4" stone, geogrid, or concrete to support flows and prolong longevity.
7. Outlet must be unobstructed and contain an energy dissipater or flow dispersion mechanism (coarse stone, plunge pool, level spreader, etc.). The objective is to spread, disperse, and slow flows and prevent erosion at the outlet.



*Broad-based dips carry concentrated flows from road surface, ditches, or guts to a stabilized outlet.*



*Outlet from dip showing grouted stone level spreader and energy dissipator to slow flows. Remove accumulated sediment, vegetation, and other buildup.*

### Installation

1. Ensure proper size, since often made too small.
2. Make sure intended flow channel, cross-slope, and side slopes to roads are as designed.
3. If earthen, ensure berm and bottom are compacted properly with vibratory roller or tamper.
4. Where paved, pour in two sections to maintain vehicular access.
5. Ensure energy dissipater or level spreader installed as designed.

*Table 4.22 Spacing guidance for dips based on road slope*

Road Grade (%)	Distance (feet)
2-4	300-200
5-7	180-160
8-10	150-140



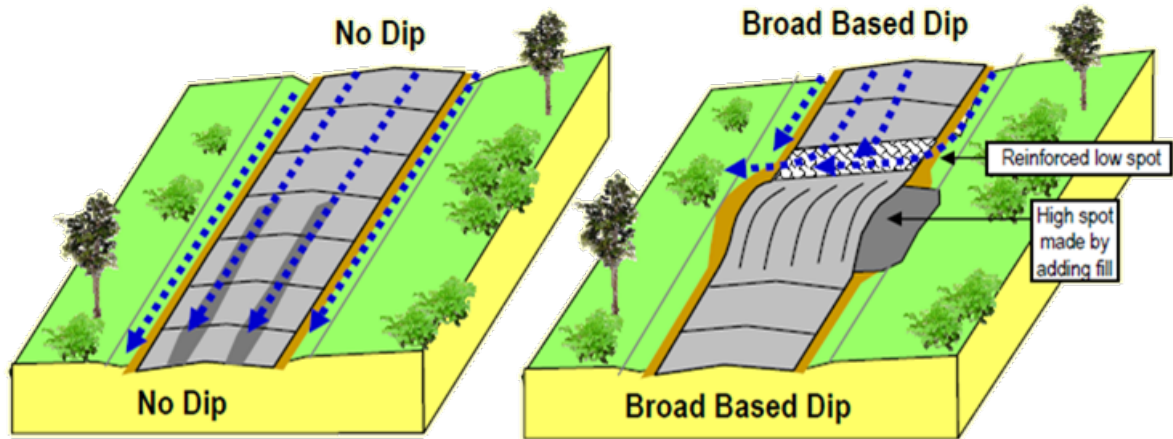

Water is allowed to run down the roadway and ditch. This builds volume and velocity which can erode the road area and deliver sediment to streams.

The Broad Based Dip forces water flowing on the roadway and in the ditches to a stable outlet area to reduce erosion. Reinforcement of the outlet area may be needed, depending on site conditions.

Figure 4.48 Broad based dip schematic (Source: Technical Bulletin, Center for Dirt & Gravel Roads Studies, 2008)

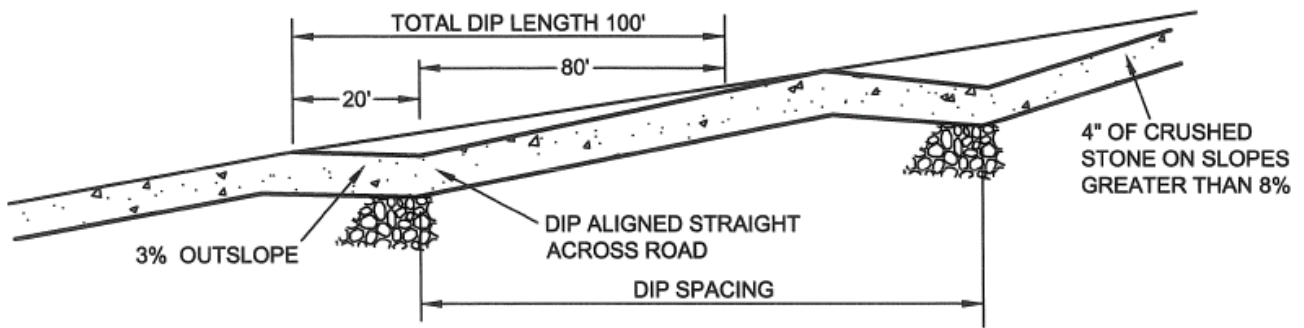

Figure 4.49 Standard detail of Broad-Based Dip for High Gradient (>5%) Roadways (from PA Department of Environmental Protection)

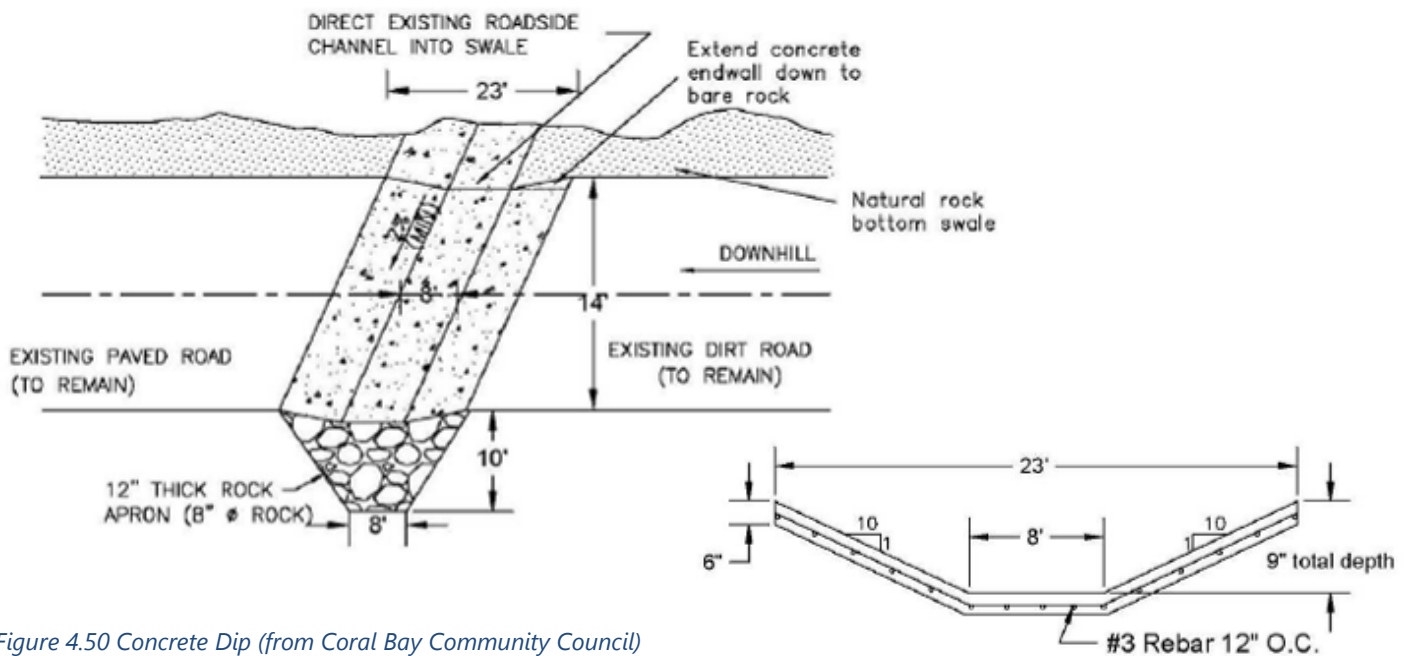

Figure 4.50 Concrete Dip (from Coral Bay Community Council)

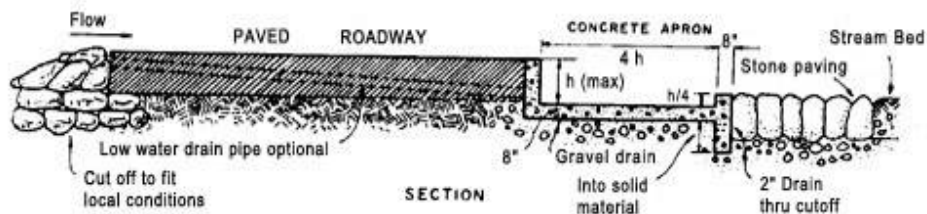
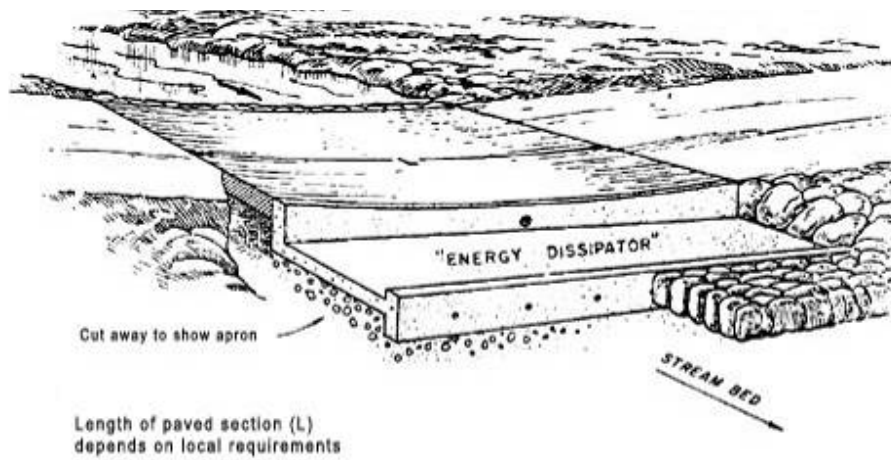

Figure 4.52 Low water crossing with energy dissipator (from FAO Watershed Field Manual).

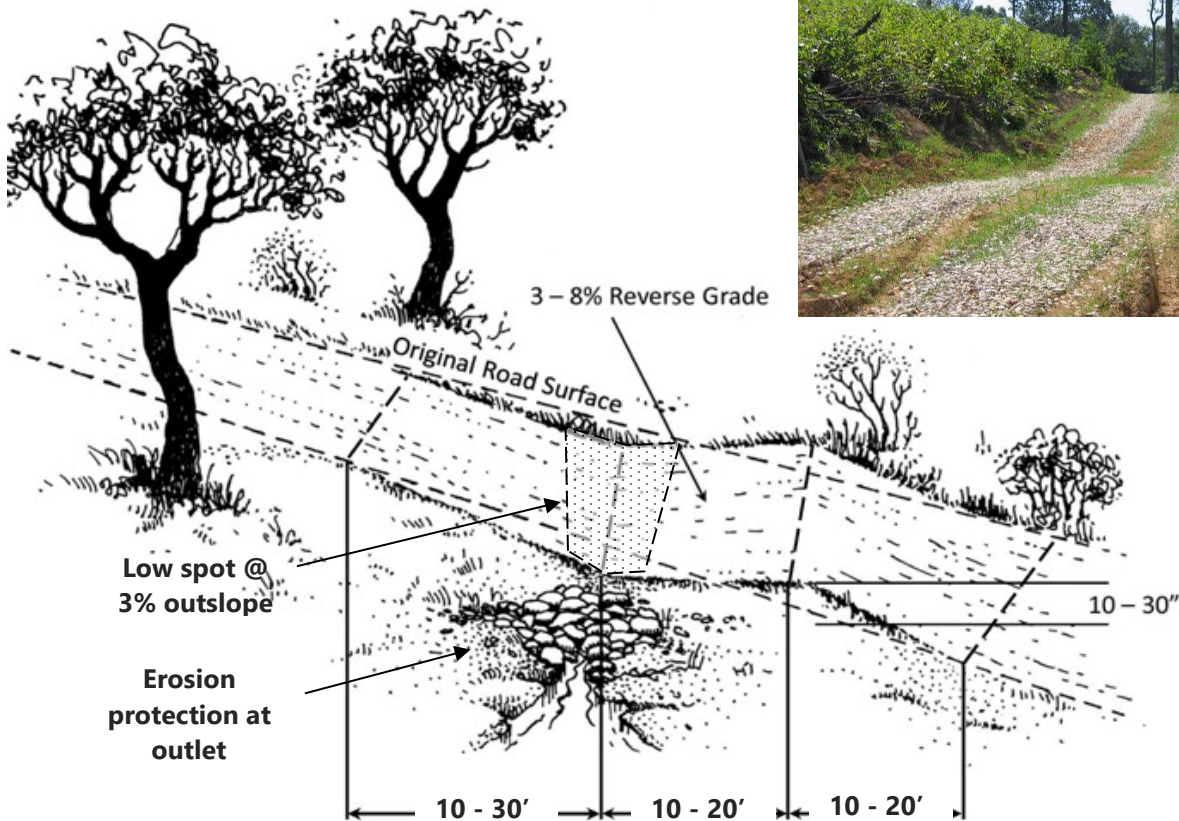

Figure 4.51 Rolling dips are shorter and steeper than broad-based dip (from Texas A&M Forest Service, 2013)



*Examples of reinforced dips (from top left to bottom right) made from concrete, concrete with embedded stones for better traction, stone/rock pad that conveys flows to a sediment trap, and drainable concrete blocks.*

## Maintenance

- Should function for years with little maintenance.
- Grade operators need to maintain dips during maintenance (slopes, transition berms, etc.).
- Ensure interface between concrete lips and road surface are maintained.
- Remove any vegetation that blocks outlet flow.
- Remove accumulated sediment within the dip and at the outlet to maintain functionality.
- Inspect after rain events. Look for signs of erosion, blockage, or bypass.

## Troubleshooting

- Vegetation, debris, or sediment buildup blocks outlet, restricts flow spreading, causes backup, or results in rerouting. This can lead to sediment accumulation in dip and erosion of road edge.
- Scour below outlet can be caused by poorly designed (or installed) level spreader or energy dissipator given the volume and rate of flow.



*Construction of concrete dip in two pours to allow vehicular access during construction.*

## CROSS-DRAINS AND CULVERTS

Cross-drains (aka cross-pipes, ditch relief drains, and culverts) are generally below surface pipes used to transfer flows from ditches to the other side of a road. Cross-drains are needed at regular intervals to prevent ditches from overflowing. Cross-drains serving as ditch relief have an angled installation to be more in line with ditch flows. Pipes connecting ditches beneath a driveway or tie-in roads are typically called road culverts. Pipes used to convey stream flows under a road are generally referred to as stream culverts and are not included here.

### Minimum Plan Requirements

- Location(s)
- Drainage area and flow calculations
- Pipe dimensions, material, slope, and cover depth
- Outfall protection
- Maintenance requirements

### Design

1. Culvert pipe sizing is based on drainage area, anticipated rainfall, soils, and slope. A minimum 18" diameter pipe is recommended to accommodate the anticipated increase in storm intensity due to climate change and lack of maintenance.
2. Elevation to be set at outlet based on natural ground elevation. This may require fill to be placed above pipe to meet cover requirements, rather than digging deeper for pipe installation.
3. Angle pipe at least 30-45 degrees across road. Align inlet to best intercept ditch flow and add ditch berm, localized depression, or other feature to minimize potential for bypass.
4. Pitch on pipe needs to have minimum 1-2% slope.
5. Cover requirements are based on pipe and road material. A rule of thumb is providing at least 1 ft of cover or ½ pipe diameter. HDPE pipes should have 1.5 ft of cover (**Figure 4.53**).
6. The pipe should extend 18-24 inches out from bank and should include some form of outlet protection (e.g., rock aprons, plunge pool, level spreader or other dissipator) to slow flow and control erosion. Consider a combination of rock and vegetation, such as vetiver (**Figure 4.54**).
7. If erosion continues to be an issue around the pipe, install a headwall.
8. Space as frequently as needed to reduce time of water on road and velocities/volumes in ditches (**Table 4.23**).



*Underground pipe used to convey ditch flow to the opposite side of the road.*

*Table 4.23 Spacing of cross-drains based on road slope*

Road Grade (%)	Cross-drain Spacing (Ft)
2	135
5	100
10	80
15	60
20	45

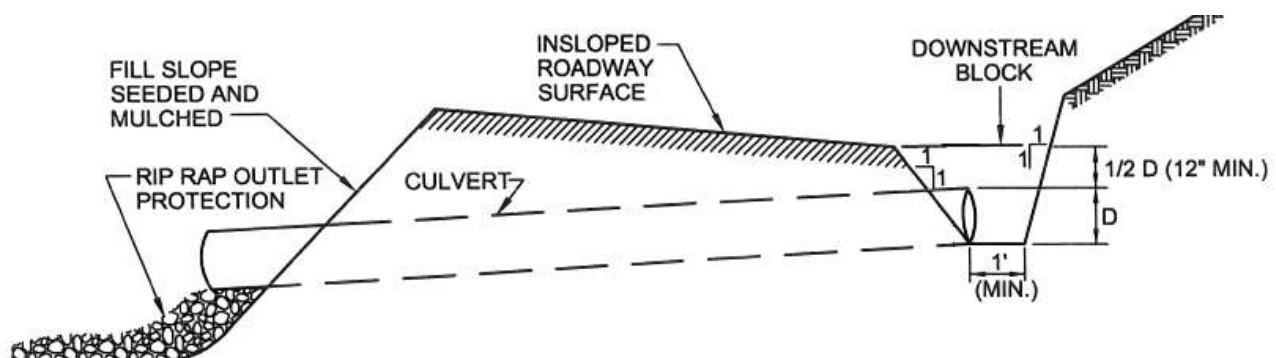

*Figure 4.53 Cross drain detail (from PA Department of Environmental Protection)*

## Installation

1. Excavate trench to lay pipe. Make sure bed is rock-free. The bottom width of the culvert trench should be twice the width of the culvert with sidewalls no steeper than 1:1.
2. Make sure inlet pipe invert is at same elevation as ditch bottom and that outlet side invert is at ground elevation.
3. Base and sidewall fill material should be compacted. Tamp backfill at regular intervals. 8-in maximum lifts.
4. Armor both entry and exit of pipe with rock, consider installation of headwall structures to prevent erosion.
5. May need to install a ditch block (berm or check dam downstream of cross-drain inlet) to force ditch flow into cross-drain. Make sure overflow can continue down ditch rather than flooding road.
6. For open top culverts, ensure opening is  $\geq 6''$  wide for shovel access.

## Maintenance & Troubleshooting

Cross-drains can require a lot of maintenance to keep them from clogging depending on conditions in the contributing drainage area. It is recommended that an inventory of all culvert locations be collected and used for inspections and maintenance tracking.

- Remove debris, sediment, and vegetation from entry and outlet points to maintain positive drainage. Keep track of removed volume in a maintenance log.
- If sediment or debris has reduced pipe capacity  $>1/4$ , clean it out. Dig out what can be removed via shovel and flush remainder. Try to collect flushed sediment at downstream end using silt fence or another barrier.
- If extensive sediment accumulation is observed, evaluate opportunities to further stabilize uphill slopes, ditches, and road surfaces. At a minimum, increase the frequency of maintenance inspections.
- If pipe ends are damaged or erosion is observed around the pipe itself, consider adding headwall.
- If cross-drain is improperly angled or sized too small, this could lead to ditch scour and bank erosion. Realignment may be needed.
- Check for piping, sinkholes, and joint separation. Replace undersized pipes.



*Digging trench for cross drain installation on Culebra, PR. Notice the pipe is laid at a 30–45-degree angle to road to better intercept ditch.*



*Grouted rock headwall around this cross-drain inlet serves as a ditch block and stabilizes inlet point.*



*Concrete culvert with metal trench grate carries ditch flow and collects surface drainage from unpaved drive on Seven Flags Rd. in St. Croix.*



Cross-drains were used to replace water bars along this demonstration road segment. Headwalls with overflow orifice were added with energy dissipators (rock and vetiver grass) in the ditch. The key to success with this installation is rapid stabilization of the ditch and prevention of headwall run-around.

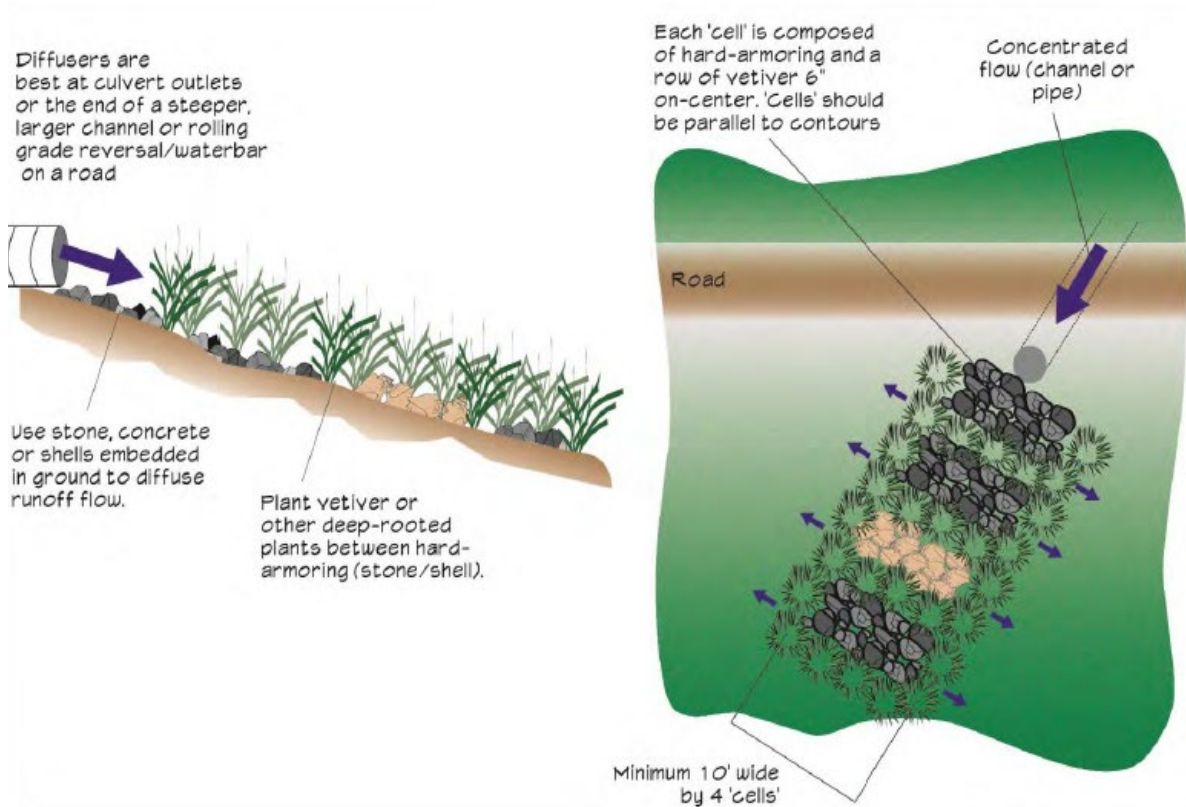

Figure 4.54 Vetiver diffuser detail from Coral Bay Community Council (2017) used to dissipate energy and disperse concentrated flows at the end of a pipe, waterbar, dip, etc. Rows should be a minimum width of 10 feet.

## WATERBARS

Waterbars are narrow berms installed diagonally across the road to reduce the amount of time and distance runoff travels on the road surface (**Figure 4.55**). Waterbars intercept shallow runoff from the road surface and direct flow towards an outlet on one side of the road (typically out-sloping). They are not intended to intercept concentrated flows from ditches (see cross-drains). Waterbars are generally made of compacted earth, concrete, or timber (e.g., repurposed telephone poles). There are several design variants to choose from based on constructability, maintenance, and drivability objectives (**Figure 4.56**). To remain effective, these practices generally require frequent inspection and maintenance.

### Minimum Plan Requirements

Details of the level spreader shall be shown on the plan and contain the following items:

- Location(s) and spacing calculations
- Dimensions and materials
- Installation methodology
- Maintenance requirements

### Design

1. Design combined berm and swale based on material, vehicular needs, and maintenance considerations. Widths are typically 3-4 ft. Waterbars should extend across full road width.
2. The berm should be on the downhill side of the water bar, with a crest height 6"-12" above grade. The berm serves as a backstop for flows collected and conveyed in the swale.
3. The greater the vertical distance between the crest and swale invert, the more capacity to handle flow and sediment, but the tougher it is for vehicles. Guidance suggests maintaining anywhere from 6-24 inch vertical distance between berm crest and swale invert. 12 inches may be a good target.
4. Skew waterbar at 30-45 degree angle across road in order to promote self-flushing and improve drivability.
5. Provide a stabilized turnout. Outlet must be unobstructed and protected against erosion (use coarse rock).
6. Spacing of waterbars is based on slope and field observations (**Table 4.24**).



Waterbars are a combination of a raised berm and swale extending the full width of the road. They intercept and direct surface flows to a stabilized turnout.

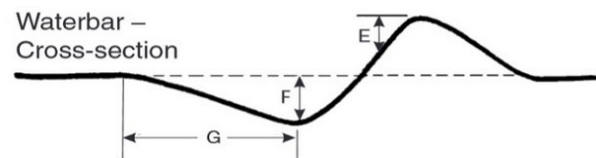
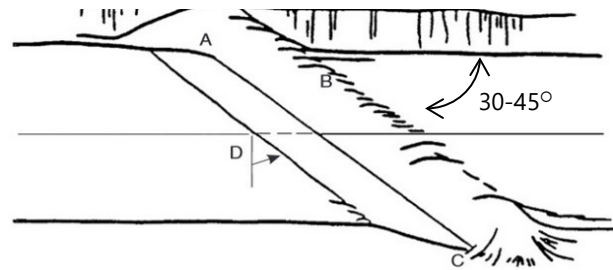

Figure 4.55 Crest height, swale depth, and other dimensions will vary based on the design variant selected (Source: FAO Conservation Guide #13).

7. Water bars can be a good feature to incorporate into the interface between a downhill concrete section and an uphill unpaved road segment to help preserve transition grading.

Table 4.24 Recommended waterbar spacing based on slope

Road Grade (%)	Waterbar Spacing (ft)
2	250
5	135
10	80
15	60
20	45

## Installation

1. Start at the uppermost practice at the top of the hill and work your way down.
2. Where paved, pour in two sections to provide temporary vehicular access.
3. Construct low enough to allow traffic to pass, but high enough to intercept flow
4. Ensure both ends are tied into edges of road, skewed at the proper angle. Maintain positive drainage on the structure of 1-2% pitch towards the outlet.
5. If earthen, make sure the berm is well compacted.

## Maintenance

Waterbars require a lot of maintenance to keep them functioning properly. Multiple waterbars in a series should be viewed as a whole system rather than as individual practices since failure at one feature will impact the other downstream practices.

- Grade operators need to maintain earthen berm shape. Vehicular traffic and runoff will impact the frequency of required regrading.
- Inspect the interface between concrete lips and the unpaved road surface after significant rain events. Anytime you put a hard edge against an unpaved surface, you should expect to see some erosion. Once the edge of the concrete becomes exposed or elevated above the road surface, runoff will begin to bypass the swale and the unpaved road surface will begin to unravel. Maintain flush grades with well-compacted backfill and/or gravel.
- Remove any accumulated sediment, vegetation, or debris from the waterbar swale to maintain positive drainage.
- Remove accumulated sediment, vegetation, or debris from the outlet location that may block discharge or cause backup on the road.
- Check discharge location for erosion and provide additional outlet protection, if needed.

## Troubleshooting

The most common issue with waterbars is that they can quickly fail and become increasingly irritating for drivers due to improper spacing and maintenance. If waterbars are spaced too infrequently, then the amount of runoff coming to each feature will be greater than the capacity of the waterbar. Bypass will begin to occur, runoff will concentrate, and edges of

the practice and the downhill road surface erosion will begin to erode. The other issue is lack of maintenance. Sediment buildup will occur in the swale and at the outlet which will reduce capacity, create backups, and lead to erosive bypassing of the structure.

To avoid these issues, it is critical that

- Waterbars are inspected frequently, especially within the first 6 months of installation and after runoff producing rain events.
- Make sure you have enough waterbars given the road slope. If there are driveways or additional contributors of off-site runoff, consider adding more waterbars than spacing guidance suggests.
- Be sure there is adequate swale depth capacity and that the waterbar is correctly skewed across the road to create self-flushing effect.
- Clean out accumulated sediments frequently and track how often cleaning is needed and the volume of material removed (# bucket loads).
- If the maintenance burden becomes excessive, either add more waterbars uphill in the series to reduce runoff volume, add strip of compacted gravel on the uphill edge of the swale or replace waterbars with cross-drains or other road practice.

**Lessons from Culebra, PR** *"The waterbars didn't work as well as we thought they should. We replaced them after two years with cross-drains pipes that work great and don't need as much maintenance attention".*

—Roberto Viqueira Ríos, Protectores de Cuencas

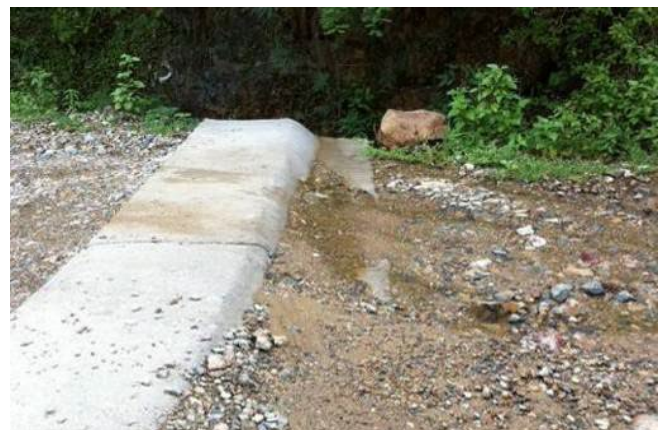

*Waterbars will clog if not maintained properly. Once runoff begins to bypass waterbars, it becomes challenging to implement a quick road fix.*



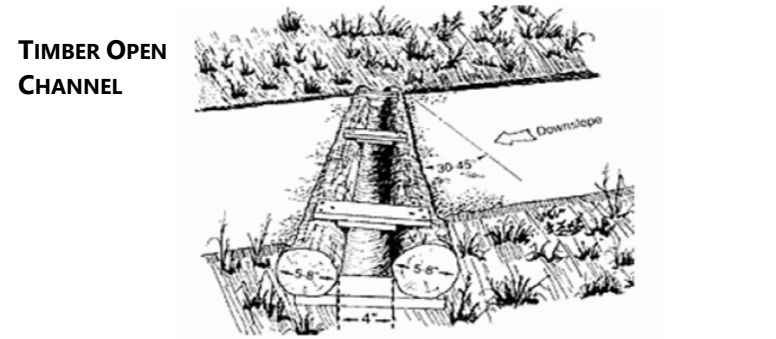
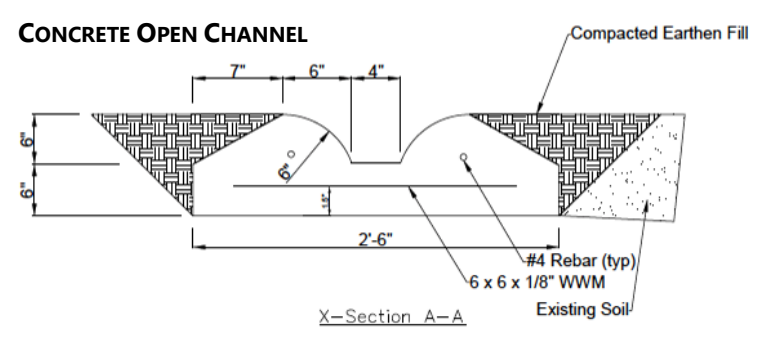
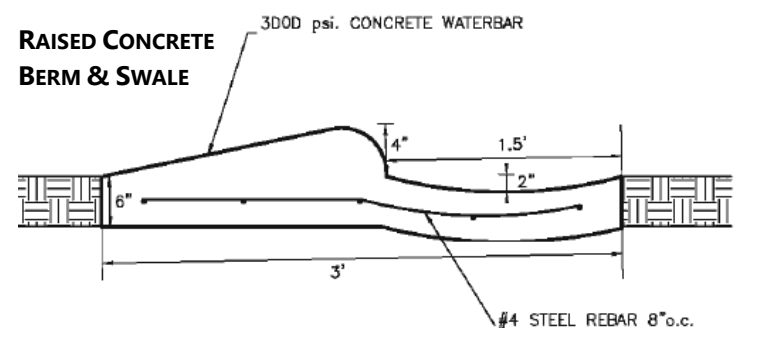
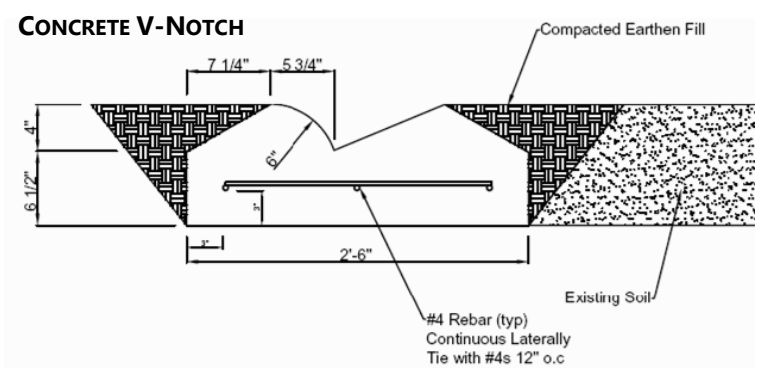
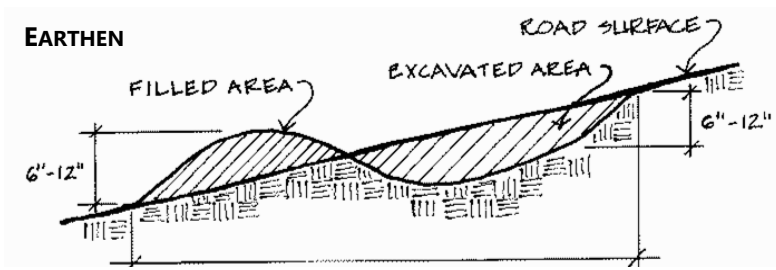

Figure 4.56 Various design alternatives for waterbars. The concrete V-notch and the raised berm & swale options are the most common. Open concrete and timber channels tend to clog quickly. Earthen waterbars are not suitable for highly trafficked roads.

## TURNOUTS

Turnouts are shallow, open channels that convey runoff away from the road or roadside ditch into an area for filtering (e.g., sediment trap, filter strip, raingarden) (**Figure 4.57**). Turnouts help reduce the total volume of runoff being carried along a roadway by breaking up the drainage area into smaller units. Use turnouts only in locations where runoff will flow positively into a filtering area well away from the road and nearby surface waters. There must be adequate outlet protection at the end of the turnout area and space for settling.

### Minimum Plan Requirements

Details of the level spreader shall be shown on the plan and contain the following items:

- Location(s)
- Estimated drainage area to practice
- Dimensions and materials
- Installation methodology
- Maintenance requirements

### Design

Turnouts are intended to be simple to install and maintain. The biggest design consideration is related to how to best manage the runoff that the turnout intercepts.

1. Discharge must be directed to a stable outlet and there must be enough space to install a stormwater practice that can store and filter runoff.
2. Angle turnouts 20-40 degrees and incorporate a berm on the downhill side to minimize bypass.
3. Space based on slope or field conditions. The intent is to reduce the time water spends on the road and in ditches (**Table 4.25**).
4. Incorporate a ditch block to help direct flows into the turnout.
5. Design for maintenance—make sure a shovel can be used to scoop out accumulated sediment.

Table 4.25 Recommended turnout spacing based on slope

Road Grade (%)	Turnout Spacing (ft)
2	250
5	135
10	80
15	60
20	45



Concrete turnout from a recently paved road takes runoff down to a vegetated filter strip.



Example of a turnout taking road runoff into a raingarden.

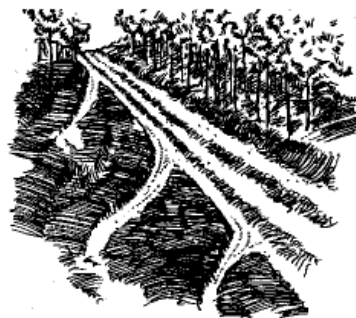
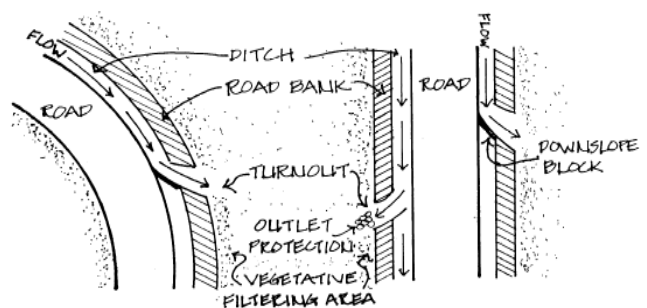

Figure 4.57 Illustrations showing road turnouts from ditches (MA Unpaved Roads BMP Manual) and directly from road surface (Alabama Forest Service).

## Installation

- Field verify the placement of turnouts based on site conditions.
- Installation methods will depend on the materials used.
- Ensure stable surface of turnout channel and outlet (see outlet protection).

## Maintenance and Troubleshooting

Sediment will accumulate in the turnout but should be removable by hand with a shovel. Remove other debris or vegetation that may block flow and cause backups, road flooding, or ditch erosion. If maintenance seems too frequent, consider options for adding more practices uphill.



*This concrete turnout directs runoff from an unpaved road to a stormwater ponding basin. Sediment deposited in the turnout needs to be removed to ensure continued drainage. Maintenance can easily be conducted with a shovel.*



*This turnout was added after the fact to address drainage issues on an unpaved access to a residential construction site on St. John. The outlet is not protected, and runoff is not conveyed to a filtering area. This type of ad hoc drainage causes offsite sedimentation and illustrates poor site design and erosion control planning.*

## GEOSYNTHETICS

Geosynthetic fabrics, grids, and containment cells can be used to add strength to road surfaces, increase the distribution of vehicle loads, and reduce upward migration of base materials and water. The strategic use of these materials can help eliminate soft spots, potholes, and ruts, and help with subsurface drainage. Separating subsoil layers with densely woven geotextile fabrics can prevent the upward migration of fines into surface layers. Highly flexible geogrids spread the weight of vehicles laterally, which reduces subgrade contact pressures (**Figure 4.58**). Geocells can provide structural support, hold surface materials in place, and allow for drainage.

### Minimum Plan Requirements

- Location(s)
- Cross section and depths
- Material specifications
- Installation methods
- Maintenance requirements

### Design

There are many types and uses of geosynthetics. Manufacturers can help in selecting the correct material and design support for your specific need. Don't let the hassle of shipping deter you from using geosynthetics. Geosynthetics will need to be ordered from off-island, but most of these materials come in rolls and are relatively light compared to other construction materials. Use of geosynthetics is growing in popularity and becoming more readily available.

### Installation

1. Follow the manufacturer's advice for handling and installation. The effectiveness of the material could be severely reduced if it is torn or punctured during placement; not properly overlapped, anchored, or attached; or otherwise installed incorrectly.

**Lessons from St. John** "We have found that 6" high GEOWEB works very well for dirt roads IF you can get a good price on buying and shipping it in, and IF you can install it with volunteer help and a cheap backhoe. If you must pay for the complete job, it gets close enough to paving costs so just do the paving and be done for 20 years."

—Sharon Coldren, Coral Bay Community Council



Geoweb installation at Johnnie Horn Rd., St. John (photo: Coral Bay Community Council).

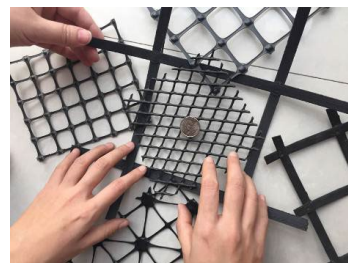

Geogrids can add structure to road surfacing and come in a variety of mesh sizes. Work with the manufacturer on product selection for your specific application and site conditions.

2. Avoid prolonged direct sunlight during storage, stack horizontally or vertically--no more than 5 rolls high, and avoid contact with sharp or other detrimental materials.
3. During installation, make sure subgrade is fit for installation (clear of debris, compacted, flat, etc.).
4. Add fill or cover materials evenly across surface. Don't use motor grader since front wheels are in front of blade.

## Maintenance and Troubleshooting

- If installed correctly, there should be relatively little maintenance. Be careful to avoid damaging geogrid during any surface maintenance or grading.
- Check for exposure of material along road edges and on surface. Add more cover material as needed.
- Remove and dispose of deformed, broken, or loose fragments.
- Watch for erosion in areas where materials may be separating due to poor installation.



Checking Geoweb installation on St. John to evaluate surface compaction and material loss over time.

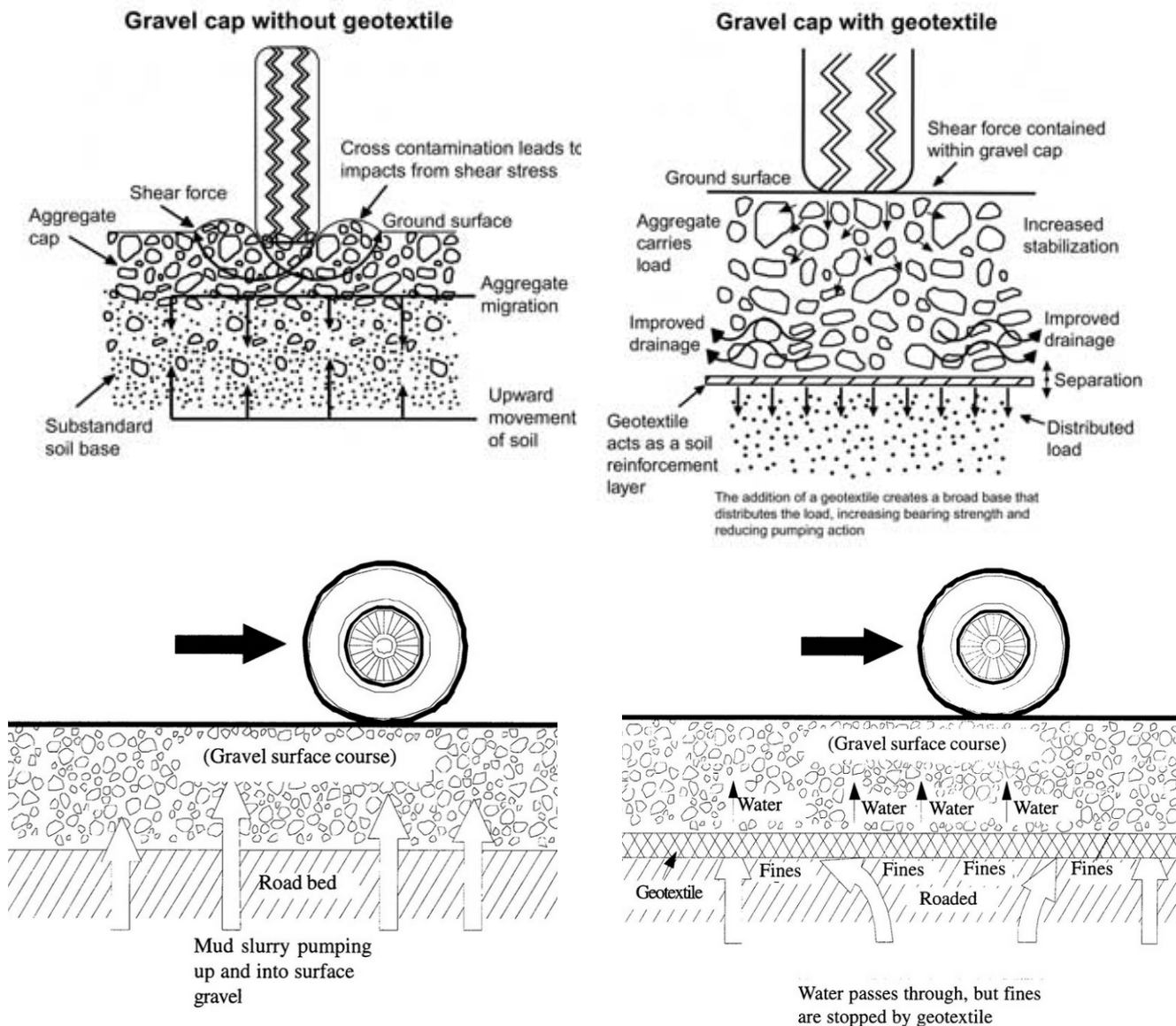

Figure 4.58 Reinforcing geogrids and textiles can help reduce the upwards migration of base materials and water, which contribute to degradation of unpaved road surfaces overtime (from [www.canaannh.org/departments/highway/index.html](http://www.canaannh.org/departments/highway/index.html)).

## SURFACE STABILIZERS

There are a wide range of organic and synthetic compounds (e.g., lignin derivatives, chlorides, resins, acrylic polymers, enzymes, and petroleum-based products) used to minimize dust (loss of fines) and improve the binding and hardening of soil/aggregate road layers. Given the lack of information on how these compounds may affect aquatic ecosystems—even those labeled as non-toxic or environmentally-safe—their use is **cautioned in coral watersheds**.

Petroleum-based products should never be used; however, cement and other pozzolanic compounds (e.g., lime or fly ash) are viable alternatives. Cement-treated base (CTB), soil cement, or modified soils are general terms describing a mixture of native soils and/or aggregates with small amounts of Portland cement and water that hardens after compaction to form a strong, durable, water-resistant road course (**Figure 4.59**). A thinner cement-treated section can reduce subgrade failures more than a thicker layer of untreated aggregate base and can extend road surface life. Soil-cement mixtures are a relatively cost-effective alternative to paving.

### Minimum Plan Requirements

- Location
- Product specifications
- Installation methodology

### Design

1. The soil and aggregate materials for use in CTB may consist of any combination of gravel, stone, sand, silt, and clay; miscellaneous material such as caliche, scoria, slag, sandshell, cinders, and ash; and recycled, crushed stone or gravel. Well-graded blends with a nominal maximum size  $\leq 3$  inches are recommended.
2. Simple lab tests can establish the proper cement content, compaction, and water requirements of the soil material to be used.
3. Nearly all soils can be stabilized, except where there is high organic content or clay content. Sandy, gravelly soils with 10-35% silt and clay are ideal. Percent cement content by weight can range anywhere from 2-8% but will be higher if silt and clay content is high. Higher cement ratios can lead to cracking. Lime can be used instead as a drying



*Adding cement-based treatments to the upper layer of soil or aggregate can increase surface longevity for a fraction of the cost of paving.*

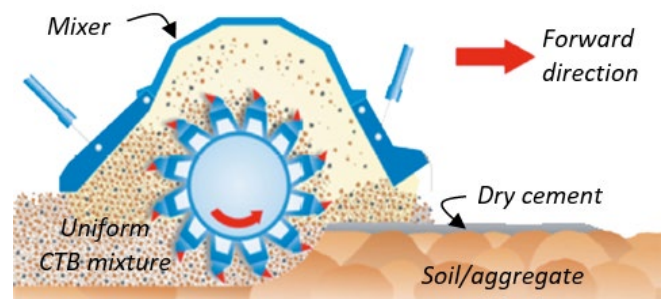

*Figure 4.59 Illustration showing how CTB is mixed into surface layer.*

agent or as a soil modifier to reduce plasticity of clayey soils.

4. Soil moisture should be  $< 10\%$ . If the mix is too dry, there is not enough moisture available to lubricate the particles into a denser formation. If the mix is too wet, the excess moisture pushes the particles apart.
5. Depth of treatment can range from 6-12 inches, should be on high end for higher volume roads.
6. Best if used below a compacted wearing course, but if used as surfacing, additional concrete ratio would produce a stronger, more durable wear surface. See the following references for more information before using CTB:
  - Portland Cement Association. *Soil-Cement Laboratory Handbook, EB05*
  - Federal Highway Administration standard specifications FP-03, Section 302.
  - Halsted, et al. 2008. *Guide to Cement Treated Base and Guide to Cement Modified Soils*.

## Installation

1. The process of creating CTB will be determined based on the equipment available and materials you are working with. Basic steps include spreading, uniform mixing, proper grading, hydrating, and compacting. If not constructed properly, it will not perform well. This must be tested in the field to best determine what works best for your soils and available equipment.
2. Prepare subgrade. Soil/aggregate should be distributed over an accurately graded, well-compacted subgrade in an even layer.
3. Cement is typically applied dry but can also be applied in a slurry form. Procedures for mixing will depend on equipment (e.g., mixer vs rototiller).
4. A thorough mixture of soil/aggregate, cement, and water must be obtained. The soil/aggregate and cement must be sufficiently blended when water contacts the mixture to prevent the formation of cement balls. The number of mixing passes depends on the type of mixer, the soil/aggregate and its moisture content, and on mixer speed. Depending on soil moisture content, you may need to pre-wet soil to facilitate mixing.
5. Uniformity of the mix can be checked by digging trenches or borings to inspect color and texture; a streaked appearance indicates insufficient mixing.
6. Compact and regrade to shape before final compaction.
7. Must be completed in small batches within 30 min to 2 hours from wetting to avoid hardening & evaporation.
8. Curing up to 7 days (keep traffic off) depending on surface finishing plans.
9. Do not use to fix potholes or other localized surface deformities.

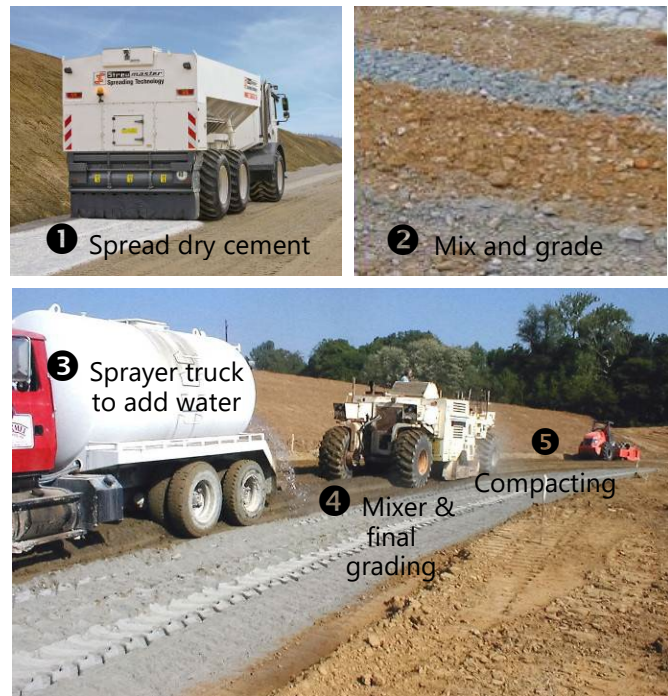

*The process of applying cement treatment as a surface stabilizer involves distributing cement by machine or by rake/hand, then multiple passes with tractor pulling a tiller or disking to mix soil/aggregate. Use a water truck to wet mixture before final grading and compaction.*

## Maintenance & Troubleshooting

Depending on conditions, surface stabilizers can extend the life of unpaved surfaces for a year or longer. This technique only works if the road is also designed to properly manage runoff (proper pitch, drainage SCMs, etc.). Temporary surface stabilization may not satisfy permanent stabilization requirements of the USVI and paving may be ultimately required.





# 5

# POST- CONSTRUCTION STORMWATER PRACTICES

<b>5.1</b>	<b>PRACTICE SELECTION SUMMARY .....</b>	<b>5-3</b>
<b>5.2</b>	<b>RUNOFF REDUCTION PRACTICES .....</b>	<b>5-7</b>
	Rainwater Harvesting .....	5-8
	Green Roofs .....	5-17
	Infiltration Practices .....	5-22
<b>5.3</b>	<b>WATER QUALITY TREATMENT PRACTICES..</b>	<b>5-41</b>
	Filters .....	5-41
	Constructed Wetlands .....	5-52
<b>5.4</b>	<b>PRETREATMENT PRACTICES .....</b>	<b>5-63</b>
	Grass Channels .....	5-63
	Sediment Forebay .....	5-66
	Deep Sump Catch Basin.....	5-67
	Proprietary Devices.....	5-70
<b>5.5</b>	<b>LARGE STORAGE PRACTICES .....</b>	<b>5-72</b>
	Stormwater Basins.....	5-72
	Underground Storage Devices.....	5-79

Low impact development (LID) is the key to reducing impacts on the environment and building resiliency in the face of a changing climate, while meeting community needs for shelter, transportation, commerce, and industry. **Chapter 3** described the three tenets of LID: Avoid, Reduce, and Manage. Sensitive site planning techniques can address the first two (avoid and reduce). Any remaining runoff generated from a site then needs to be managed with a suite of Post Construction Stormwater Control Measures (SCMs) dispersed throughout a site. The SCMs described here are grouped by function into four general categories (**Figure 5.1**): Runoff Reduction, Water Quality, Pretreatment, and Storage.

The Runoff Reduction and Water Quality SCMs in this chapter are Green Stormwater Infrastructure (GSI) practices. GSI is a nature-based approach to

stormwater treatment and management. These stormwater practices are designed to mimic nature and use the natural filtration properties of soil and plants to remove pollutants from stormwater runoff prior to discharging to the storm drain system or receiving waterbodies.

This chapter provides design criteria and standard details for SCMs, plan requirements, and maintenance activities. Calculations and look up tables are provided, where applicable. Given the variability of site conditions and land use, this information is not intended to be all encompassing; rather it should provide enough information for designers, contractors, and permitting agents to design, implement, and maintain most SCMs to fully meet the ten stormwater standards from **Chapter 2**.

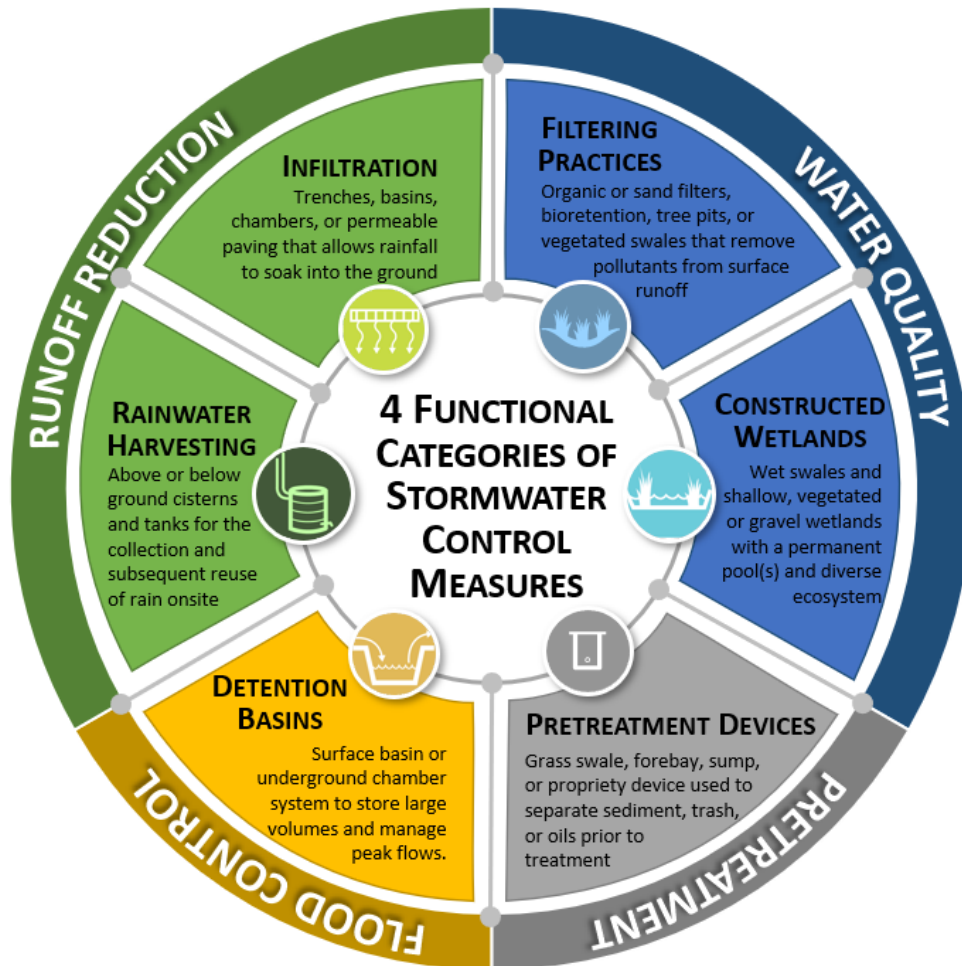

Figure 5.1 The four functional categories of Post-construction Stormwater Control Measures (SCMs).

If the recommended design criteria for a particular SCM cannot be met at a site, an alternative SCM should be selected, or adequate justification must be provided to the approving agency why the particular criteria is not necessary or practicable. In cases where the practice is a proprietary product, specifications and design criteria can typically be obtained from vendors. The figures and photographs included in this chapter are schematic graphics only. Design plans should be consistent with the schematic figures when using the method or practice described but must be completely detailed by the designer for site-specific conditions and construction purposes.

Design criteria are provided for the following categories for most practices:

**Feasibility:** Identify site considerations that may restrict the use of a practice.

**Minimum Plan Requirements:**

**Design**

- **Conveyance:** Convey runoff to the practice in a manner that is safe, minimizes erosion and disruption to natural channels, and promotes filtering and infiltration.
- **Pretreatment:** Trap sediment and debris before they enter the SCM, thus reducing the maintenance burden and ensuring a long-lived practice.
- **Treatment/Geometry:** Provide the target volume through design elements.
- **Vegetation:** Provide vegetation that enhances the pollutant removal and aesthetic value of the practice.

**Maintenance:** Maintain the long-term performance of the practice through regular maintenance activities, and through design elements that ease the maintenance burden.

## 5.1 PRACTICE SELECTION SUMMARY

During development, both the landscape and the hydrology of a parcel of land can be significantly altered. The following may occur both during and after development:

- Soils are compacted;

- Impermeable surfaces increase;
- Water retention on-site decreases;
- Channels and other water conveyances are built;
- Slopes change;
- Vegetative cover decreases; and
- Soil surface roughness decreases.

These changes result in increased post-construction runoff volumes and velocities (or speeds) which can scour and erode guts, steep slopes, and unvegetated areas, and cause downstream siltation of roads, parking lots, yards, ponds, beaches, seagrass beds, coral reefs, and other coastal areas. In addition, impervious surfaces can also increase water temperatures.

The post-construction SCMs in this chapter are meant to be used together throughout a site to address these impacts and meet the various stormwater requirements in **Chapter 2**. The four categories are described below.

**Runoff reduction** practices reduce the total amount of runoff leaving a site by capturing and reusing the stormwater ("rainwater harvesting") or infiltrating the runoff. A combination of these practices and the site design techniques in **Chapter 3** should be used to meet the Runoff Reduction Standard (SW 2) such that no runoff leaves the site during the 1-year storm.

If a site is not able to meet the full Runoff Reduction Standard, then **Water quality** SCMs need to treat 1-inch of runoff from impervious surfaces. These SCMs include filters and constructed wetlands. Filtration practices treat sheet flow runoff by using vegetation and specific soil to filter pollutants. In some cases, filters could also infiltrate runoff and thus, be used toward the Runoff Reduction Standard. Constructed wetland practices treat runoff by mimicking natural wetlands. These practices intercept groundwater or have an impermeable liner to maintain a permanent pool and use wetland plants to absorb nutrients and other pollutants. Constructed wetlands typically cannot be used to meet the Runoff Reduction Standard.

**Pretreatment** practices help collect a majority of the larger debris and sediment from runoff to focus maintenance activities in one location, allowing the main runoff reduction/treatment practices to remove smaller and/or soluble pollutants. In the absence of

evidence of contamination, removed debris may be taken to a landfill or other permitted facility or handled similarly to contents from street sweeping activities. Sediment testing may be required prior to sediment disposal when a hotspot is present.

Large *storage* practices, or detention practices, temporarily hold runoff from large storm events (1-yr storm and greater) to control runoff rates and volumes and minimize downstream erosion. These must be used in combination with runoff reduction and/or water quality practices to meet the stormwater standards.

GSI is most effective if a variety of SCMs are dispersed throughout a site and as close as possible to the source of runoff. This reduces dependence on just one stormwater practice for a large drainage area, reducing risk during large storm events and adding resiliency in our changing climate.

**Table 5.1** summarizes the suite of SCMs by category, as well as by the key stormwater standards they address. Designers should use this table to help determine the appropriate options for their sites. The relevant stormwater standards are as follows:

SW-2 Runoff Reduction

SW-3 Water Quality

SW-4 Gut Protection

SW-5 Conveyance

SW-6 Overbank Flooding

SW-9 Pollutant Hotspots

Table 5.1 Summary of acceptable SCMs and the key stormwater standards they can address. Solid circles indicate the practice meets the standard most of the time while hollow circles indicate the practice may be able to meet the standard under certain site conditions or design options.

Group	SCM	Description	SW 2	SW 3	SW 4	SW 5	SW 6	SW 9
<b>R U N O F F R E D U C T I O N P R A C T I C E S</b>								
<b>Rainwater Harvesting</b>	<b>Cisterns</b>	An aboveground or underground tank that is used to capture rainwater for reuse, either treated for drinking water or just for gray water or irrigation.	●	●	○			●
	<b>Green Roofs</b>	Roof systems that capture rainwater to support a variety of vegetation. These practices also provide energy savings.	●	●	○			●
<b>Infiltration</b>	<b>Infiltration Trenches/ Chambers/ Dry Wells</b>	An infiltration practice that stores the target volume in the void spaces of a trench or open chamber filled with or embedded in clean gravel before it is infiltrated into underlying soils. <sup>1</sup>	●	○	○		○	
	<b>Infiltration Basin</b>	An infiltration practice that stores the water quality volume in a shallow surface depression before it is infiltrated into the underlying soils. <sup>1</sup>	●	○	●		●	
	<b>Permeable Paving</b>	A practice that stores the water quality volume in the void spaces of a clean sand or gravel base before it is infiltrated into the underlying soils. <sup>1</sup>	●	●	●			
<b>W A T E R Q U A L I T Y P R A C T I C E S</b>								
<b>Filtering Practices</b>	<b>Bioretention</b>	A shallow depression that treats stormwater as it flows through a soil matrix, and is returned to the storm drain system, or infiltrated into underlying soils or substratum. Includes variants such as sand and organic filters.	○	●	○		○	○
	<b>Dry swale</b>	An open vegetated channel with a shallow slope explicitly designed to detain and promote filtration of stormwater runoff into an underlying fabricated soil matrix.	○	●	○			
	<b>Tree Trench</b>	An underground trench along a road that treats runoff while also providing water and nutrients for roadside trees or other vegetation.	○	●	○			
<b>Constructed Wetlands</b>	<b>Shallow Marsh</b>	A surface constructed wetland that provides treatment primarily in a shallow vegetated permanent pool graded with microtopography.	○	●	○		●	
	<b>Gravel Wetland</b>	A constructed wetland that provides water quality treatment primarily in a saturated gravel bed with emergent vegetation.	○	●	○		●	●
	<b>Wet Swale</b>	An open vegetated channel or depression designed to retain water or	○	●	○			

<sup>1</sup> For treating the first inch of runoff, the bottom of infiltration practices should be in the natural soil profile, i.e., should not be located in bedrock.

Group	SCM	Description	SW 2	SW 3	SW 4	SW 5	SW 6	SW 9
		intercept groundwater for water quality treatment.						
P R E T R E A T M E N T P R A C T I C E S								
Pretreatment	<b>Grass Channel</b>	Grassy swale used to slow runoff and remove sediment and other debris prior to a treatment SCM.				○		
	<b>Sediment Forebay</b>	Small basin used prior to a treatment SCM to capture sediment and debris						●
	<b>Deep Sump Catch Basins</b>	Inlet in roadways with a deep sump to capture sediment and debris.						●
	<b>Proprietary Devices</b>	Proprietary devices are structures with different internal components to boost pollutant removal, but not to the levels appropriate to be considered treatment practices.						●
L A R G E S T O R A G E P R A C T I C E S								
Detention	<b>Extended Detention Basins</b>	Large basin with an outlet structure designed to slowly release runoff over an extended period of time. Variants include wet and dry basins.			●		●	○
	<b>Underground Storage Chambers</b>	Underground storage chambers that are intended to hold and slowly release runoff over time, rather than infiltrating it.			●		●	○

## 5.2 RUNOFF REDUCTION PRACTICES

Runoff reduction practices are effective for reducing the total runoff from a development site and help to meet the requirements of the Runoff Reduction Standard, in combination with measures described in **Chapter 3**. Runoff reduction practices include rainwater harvesting measures as well as infiltrating practices. A key to runoff reduction is rethinking our hardscapes in development, such as rooftops, driveways and parking lots. These areas often consume a high percentage of a site’s development envelope, are impervious, and generate surface stormwater runoff when it rains. Interestingly, runoff from roofs is generally viewed as a resource, while runoff from parking lots and other paved areas is considered a nuisance to be quickly conveyed off-site. In the Virgin Islands, rooftops are frequently used to harvest valuable rainwater via cisterns for both potable and non-potable reuse. Alternatively, pavements are generally designed exclusively for transport and parking of vehicles and provision of pedestrian walkways with little consideration of hydrologic impacts. Constructed of concrete, asphalt, compacted gravel, or crushed coral, the runoff generated from these surfaces is often contaminated by oils, heavy metals, trash, and other pollutants that have collected on the pavement.

Given that these hardscapes take up significant acreages of the developed landscape and generate excessive runoff and pollutant loads, it makes sense to



*Concrete grid pavers used at multi-family housing complex on St. John.*

rethink how these areas can be more efficiently utilized to meet vehicular needs, pedestrian access, water supply, and stormwater management functions. This can be done with a series of common sense approaches to parking lot, street, driveway, and roof design that maintain function and safety while reducing that amount of runoff that must be managed by other practices. This section describes design criteria for two main types of runoff reduction SCMs, rainwater harvesting and infiltration practices.

The figures and photographs included in this section are schematic graphics only. Design plans should be consistent with the schematic figures when using the method or practice described, but must be completely detailed by the designer for site-specific conditions and construction purposes.

*Table 5.2 Summary of runoff reduction SCMs and some of their typical relative benefits.*

Benefits	Rainwater Harvesting		Infiltration Practices		
	Cisterns	Green Roofs	Surface Infiltration	Underground Infiltration Chambers	Permeable Pavement
Easy to Install			●		
Inexpensive			●		
Space efficient	●	●		●	●
Good for hotspots	○	○			
Low Maintenance	○	○	●		
Other Benefits (Drinking water, stabilization, energy savings etc.)	●	●			●



## RAINWATER HARVESTING

Rainwater harvesting systems intercept, divert, and store rainfall for future use.

Rainwater that falls on a rooftop is collected and conveyed into an above or below ground storage tank where it can be used for non-potable water uses and on-site stormwater infiltration. Non-potable uses may include flushing of toilets and urinals inside buildings, landscape irrigation, exterior washing (e.g., car washes, building facades, sidewalks, street sweepers, fire trucks, etc.), fire suppression (sprinkler) systems, supply for chilled water cooling towers, dust control, replenishing and operation of water features and water fountains, and laundry, if approved by the local authority. Replenishing of pools may be acceptable if special measures are taken, as approved by the appropriate regulatory authority.

*In much of the Virgin Islands, harvested rainwater is used to supplement or completely provide potable water supply. Since water collected from rooftops can carry dangerous bacteria and viruses from organic matter and animal waste, it is vital that appropriate treatment systems to treat water to potable standards need to be added to the system components. Users must be careful with the type of treatment used – some disinfectants like chlorine can create dangerous by-products. These design criteria are focused on meeting stormwater requirements, but it is imperative that designs intended for potable water use follow public health standards. Typically, a three-part filtration system with UV light is recommended for best treatment of cistern water, but reach out to local public health agencies for more information.*

### Feasibility

Rainwater harvesting systems:

- Can be installed above or below ground;
- Are flexible in design, where design volumes and flows are dependent on the size of the tank or cistern selected as well as the year-round demand for reuse of the water;



*Islands have an inherent interest in rainwater harvesting to reduce the burden on drinking water supplies. Cisterns are commonly used for small-scale potable water or to satisfy non-potable needs (e.g., irrigation, toilet flushing, car washing, fire suppression).*

- Can include flow control technologies to allow for manual or automated drawdown prior to storm events;
- Are adaptable to the wet season and dry season conditions by adding a “soakaway” valve to help drain the tank based on indoor and outdoor usage adjustments; and
- Can be combined with down-gradient BMPs (e.g., infiltration trench, rain garden).

This type of system is recommended for USVI to: (1) reduce the volume of stormwater generated, and (2) relieve pressure on the potable water supply. Rainwater harvesting can be adapted to the wet season and dry season conditions by adding a “soakaway” valve to help drain the tank during the wet season and/or adjusting the indoor and outdoor uses of the water.

- Rainwater harvesting systems are flexible and can be designed to manage the runoff reduction, water quality volume (WQv), the gut protection volume (Gpv), and/or overbank flood storage (Qp). The design volumes and flows are dependent on the size of the tank or cistern selected as well as the year-round demand for reuse of the water. The Runoff Reduction standard can also be met by using rainwater harvesting in combination with a downgradient



infiltration practice (e.g., infiltration trench, rain garden).

- Site topography and tank location should be considered as they relate to all of the inlet and outlet invert elevations in the rainwater harvesting system. The total elevation drop will be realized beginning from the downspout leaders to the final mechanism receiving gravity-fed discharge and/or overflow from the cistern.
- Underground storage tanks are most appropriate in areas where the tank can be buried above the water table. The tank should be located in a manner that will not subject it to flooding. In areas where the tank is to be buried below the water table, special design features must be employed, such as sufficiently securing the tank (to keep it from “floating”), conducting buoyancy calculations when the tank is empty, etc. The tank must also be installed according to the tank manufacturer’s specifications.
- All underground utilities must be taken into consideration during the design of underground rainwater harvesting systems. Appropriate minimum setbacks from septic drainfields should be observed, as specified by appropriate municipal codes.
- The contributing drainage area (CDA) to the cistern is the impervious area draining to the tank. In general, only rooftop surfaces should be included in the CDA. Parking lots and other paved areas can be used in rare circumstances with appropriate treatment (oil/water separators) and

approval of the plan-approving authority. Runoff should be routed directly from rooftops to rainwater harvesting systems in closed roof drain systems or storm drain pipes, avoiding surface drainage, which could allow for increased contamination of the water.

- The quality of the harvested rainwater will vary according to the roof material over which it flows. Water harvested from certain types of rooftops, such as asphalt sealcoats, tar and gravel, painted roofs or galvanized metal roofs, may leach trace metals and other toxic compounds. In general, harvesting rainwater from such roofs should be avoided, unless new information determines that these materials are sufficient for the intended use and are allowed by regulations.
- Harvesting rainwater can be an effective method to prevent contamination of rooftop runoff that would result from mixing it with ground-level runoff from a stormwater hotspot operation. In some cases, however, industrial roof surfaces may also be designated as stormwater hotspots.
- Cistern overflow devices should be designed to avoid causing ponding or soil saturation within 10 feet of building foundations. Storage tanks should be designed to be watertight to prevent water damage when placed near building foundations. In general, it is recommended that underground tanks be set at least 10 feet from any building foundation.



*Examples of rainwater harvesting for backup potable and other uses.*

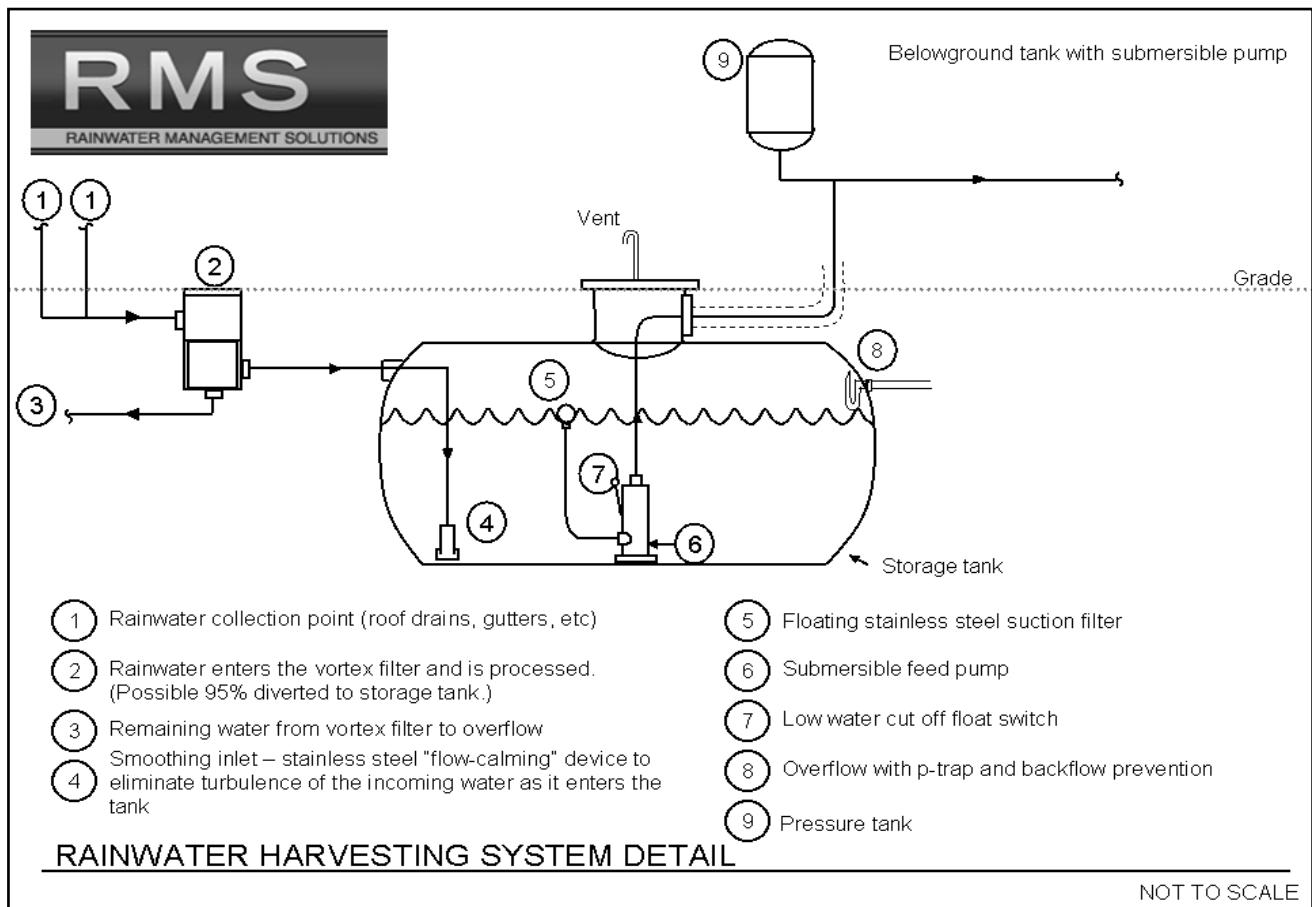

Figure 5.2 Typical system components for rainwater harvesting. Graphic courtesy of Rainwater Management Solutions, Inc.

- Whenever possible, underground rainwater harvesting systems should be placed in areas without vehicle traffic or be designed to support live loads from heavy trucks, a requirement that may significantly increase construction costs.
- Pre-treatment: Screening, First-Flush Diverters, and Filters
- Storage tanks
- Distribution system
- Down-gradient small infiltration practice

### Minimum Plan Requirements

The following items related to rainwater harvesting must be shown on the design plans and/or included in the technical specifications:

- Location of all components of the rainwater harvesting system on the site plan
- Details showing pipe and tank connections, tank dimensions, and other components
- Installation methods and sequencing
- Specifications for pipe and tank materials

### Design

There are six primary components of a rainwater harvesting system:

- Rooftop surface
- Collection and conveyance system (e.g. gutters)

**Figure 5.2** illustrates the typical system components for rainwater harvesting described in this section, using an underground tank as an example.

### Rooftop Surface

The rooftop should be made of smooth, non-porous material with efficient drainage either from a sloped roof or an efficient roof drain system. Slow drainage of the roof leads to poor rinsing and a prolonged first flush, which can decrease water quality. If the harvested rainwater will be used for potable uses, or uses with significant human exposure (e.g., pool filling, watering vegetable gardens), care should be taken in the choice of roof materials. Some materials may leach toxic chemicals making the water unsafe for humans.

## Conveyance

The collection and conveyance system consists of the gutters, downspouts and pipes that channel stormwater runoff into storage tanks. Gutters and downspouts should be designed as they would for a building without a rainwater harvesting system. Aluminum, round-bottom gutters and round downspouts are generally recommended for rainwater harvesting.

Minimum slopes of gutters should be specified. They should be designed to convey the 10-year storm, specifying size and minimum slope, if credit will be sought for gut protection and/or overbank flood control. In all cases, gutters should be installed at a minimum of 0.5% slope for 2/3 of the length and at 1% for the remaining 1/3 of the length nearest the storage tank.

Pipes (connecting downspouts to the cistern tank) should be at a minimum slope of 1.5% and sized/designed to convey the intended design storm. In some cases, a steeper slope and larger sizes may be recommended and/or necessary to convey the required runoff. Gutters and downspouts should be kept clean and free of debris and rust.

## Pretreatment

### **Screening, First Flush Diverters and Filters.**

Pre-filtration is required to keep sediment, leaves and vegetative debris, contaminants and other debris from the system. Leaf screens and gutter guards meet the minimal requirement for pre-filtration of small systems (such as residential and small-scale commercial applications), although direct water filtration is preferred. All pre-filtration devices should be low-maintenance or maintenance-free. The purpose of pre-filtration is to significantly cut down on system maintenance by preventing organic buildup in the tank, thereby decreasing microbial food sources.

For larger tank systems, the initial first flush must be diverted from the system before rainwater enters the storage tank. The amount of this diversion can range between the first 0.02 to 0.06 inches of rooftop runoff.

The diverted flows (first flush diversion and overflow from the filter) must be directed to an acceptable

pervious flow path, that will not cause erosion during a 1-year storm, or to an appropriate stormwater practice on the property, such as a down-gradient small infiltration practice (which can also receive overflow from the tank itself).

Various pretreatment mechanisms are described below:

- Leaf Screens (small-scale applications). Leaf screens are mesh screens installed over either the gutter or downspout to separate leaves and other large debris from rooftop runoff. Leaf screens must be regularly cleaned to be effective; if not maintained, they can become clogged and prevent rainwater from flowing into the storage tanks. Built-up debris can also harbor bacterial growth within gutters or downspouts.
- First Flush Diverters. First flush diverters direct the initial pulse of stormwater runoff away from the storage tank. While leaf screens effectively remove larger debris such as leaves, twigs and blooms from harvested rainwater, first flush diverters can be used to remove smaller contaminants such as dust, pollen and bird and rodent feces. Simple first flush diverters require active management, by draining the first flush water volume to a pervious area following each rainstorm. First flush diverters may be the preferred pre-treatment method if the water is to be used for indoor purposes. A vortex filter (see below) may serve as an effective pre-tank filtration device and first flush diverter.
- Roof Washers. Roof washers are placed just upgradient of storage tanks and are used to filter small debris from harvested rainwater. Roof washers consist of a tank, usually between 25 and 50 gallons in size, with leaf strainers and a filter with openings as small as 30-microns. The filter functions to remove very small particulate matter from harvested rainwater. All roof washers must be cleaned on a regular basis.
- Vortex Filters. For larger rooftop areas, vortex filters are recommended to provide filtering of rooftop rainwater. In addition to the initial first flush diversion, filters have an associated



Assuming that rooftop runoff collected in cisterns is “clean” may not always be true, as is illustrated here behind a retail center on St. Thomas.

efficiency curve that estimates the percentage of rooftop runoff that will be conveyed through the filter to the storage tank. If filters are not sized properly, a large portion of the rooftop runoff may be diverted and not conveyed to the tank for storage. To receive credit for capturing the water quality volume ( $WQ_v$ ), the minimum filter efficiency should be 95% for the appropriate  $WQ_v$  rainfall intensity.

- **Potable Water Pretreatment.** If rainwater is to be used for drinking water, careful attention is needed for pretreatment. A recommended effective approach is a three-part filter that includes treatment with UV light. See other public health guidance for more information on this practice.

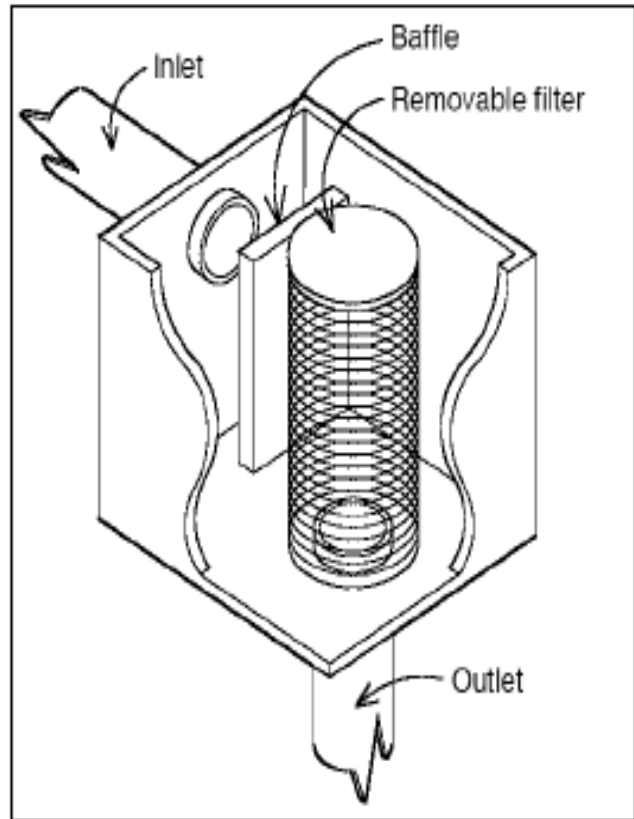

First flush diverter.

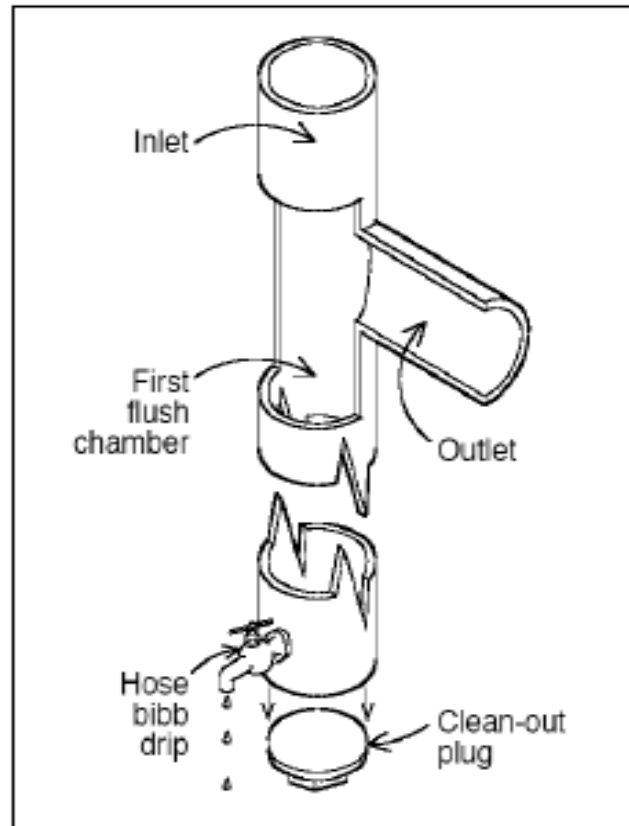

Roof washer.

## Storage Tanks

The storage tank is the most important and typically the most expensive component of a rainwater harvesting system. Cistern capacities range from 250 to over 30,000 gallons. Multiple tanks can be placed adjacent to each other and connected with pipes to balance water levels and increase overall storage as needed, as well as providing redundancy for maintenance needs. For example, when one tank is being cleaned, the other can still be used. Typical rainwater harvesting system capacities for residential use range from 1,500 to 5,000 gallons. Storage tank volumes are calculated to meet the water demand and stormwater treatment volume standards.

**Treatment volumes** can be “stacked” to meet runoff reduction, water quality, gut protection, and/or overbank flood control standards. However, smaller tanks that meet only the water quality standard can also be coupled with other downgradient practices that manage the channel protection and flood control requirements (e.g., rainwater tanks that drains to a downgradient basin). It is important to note that since tanks will often have water in them already when the next storm comes, designers can only take credit for half the total available tank volume.

Rainwater harvesting tanks can be made of many materials and configured in various shapes, depending on the type used, the site conditions, and the availability of various tanks. For example, configurations can be rectangular, L-shaped, or step down vertically to match the topography of a site. The following factors should be considered when designing a rainwater harvesting system and selecting a storage tank:

- Aboveground storage tanks should be UV and impact resistant.
- Underground storage tanks must be designed to support the overlying soil and any other anticipated loads (e.g., vehicles, pedestrian traffic, etc.).
- Underground rainwater harvesting systems should have a standard size manhole or equivalent opening to allow access for cleaning, inspection, and maintenance purposes. This access point should be secured/locked to prevent unwanted access.



*Various tank materials and configurations*

- All rainwater harvesting systems should be sealed using a water-safe, non-toxic substance.
- For use during both wet and dry seasons, tanks should have a “soakaway valve” near the bottom (above the dead storage). This valve can be left open during the wet season to help keep the tank draining, and closed during the dry season to maximize storage for other uses. The valve can also be adjustable to allow the correct balance between tank drainage and other uses.
- Rainwater harvesting systems may be ordered from a manufacturer or can be constructed on site from a variety of materials. **Table 5.3** below compares the advantages and disadvantages of different storage tank materials.
- Storage tanks should be opaque or otherwise protected from direct sunlight to inhibit algae growth and should be screened to discourage mosquito breeding and reproduction.
- Dead storage below the outlet to the distribution system and an air gap at the top of the tank should be added to the total volume. For gravity-fed systems, a minimum of 6 inches of dead

storage should be provided. For systems using a pump, the dead storage depth will be based on the pump specifications.

- Any hookup to a municipal backup water supply should have a backflow prevention device to keep municipal water separate from stored rainwater; this may include incorporating an air gap to separate the two supplies. Local codes may have specifications for this.

### Distribution System

Most distribution systems require a pump to convey harvested rainwater from the storage tank to its final destination, whether inside the building, an automated irrigation system, or gradually discharged to a downgradient infiltration practice. The rainwater harvesting system should be equipped with an appropriately-sized pump that produces sufficient pressure for all end-uses. The municipality may require the separate plumbing to be labeled as non-potable.

*Table 5.3 Advantages & Disadvantage of Various Cistern Materials (CWP and HW, 2010)*

Tank Material	Advantages	Disadvantages
<b>Fiberglass</b>	Commercially available, alterable and moveable; durable with little maintenance; light weight; integral fittings (no leaks); broad application	Must be installed on smooth, solid, level footing; pressure proof for below-ground installation; expensive in smaller sizes
<b>Polyethylene</b>	Commercially available, alterable, moveable, affordable; available in wide range of sizes; can install above or below ground; little maintenance; broad application	Can be UV-degradable; must be painted or tinted for above-ground installations; pressure-proof for below-ground installation
<b>Modular Storage</b>	Can modify to topography; can alter footprint and create various shapes to fit site; relatively inexpensive	Longevity may be less than other materials; higher risk of puncturing of water tight membrane during construction
<b>Plastic Barrels</b>	Commercially available; inexpensive	Low storage capacity (20 to 50 gallons); limited application
<b>Galvanized Steel</b>	Commercially available, alterable and moveable; available in a range of sizes; film develops inside to prevent corrosion	Possible external corrosion and rust; must be lined for potable use; can only install above ground; soil pH may limit underground applications
<b>Steel Drums</b>	Commercially available, alterable and moveable	Small storage capacity; prone to corrosion, and rust can lead to leaching of metals; verify prior to reuse for toxics; water pH and soil pH may also limit applications
<b>FerroConcrete</b>	Durable and immovable; suitable for above or below ground installations	Potential to crack and leak; expensive
<b>Cast in Place Concrete</b>	Durable, immovable, versatile; suitable for above or below ground installations; neutralizes acid rain	Potential to crack and leak; permanent; will need to provide adequate platform and design for placement in clay soils
<b>Stone or concrete Block</b>	Durable and immovable; keeps water relatively cool in hot climates	Difficult to maintain; expensive to build

The typical pump and pressure tank arrangement consists of a multi-stage centrifugal pump, which draws water out of the storage tank and sends it into the pressure tank, where it is stored for distribution. When water is drawn out of the pressure tank, the pump activates to supply additional water to the distribution system. The backflow preventer is required to separate harvested rainwater from the main potable water distribution lines. A drain plug or cleanout sump, also draining to a pervious area, should be installed to allow the system to be completely emptied, if needed.

### Overflow, Filter Path, and Downgradient Small Infiltration or Treatment Practice

An overflow mechanism should be included in the rainwater harvesting system design in order to handle an individual storm event or multiple storms in succession that exceed the capacity of the tank (especially during the wet season). Overflow pipes should have a capacity equal to or greater than the inflow pipe(s) and have a diameter and slope sufficient to drain the cistern while maintaining an adequate freeboard height. The overflow pipe should be screened to prevent access to the tank by rodents and birds.

The overflow and first-flush diversion filter path is a pervious, grass, or adequately lined corridor that extends from the overflow to the next stormwater practice, the street, an adequate existing or proposed channel, or the storm drain system. The filter path must be graded with a slope that results in sheet flow or positive drainage conditions. If compacted or impermeable soils are present along the filter path, compost amendments may be needed. It is likely that wet season operation will involve frequent or continuous drainage of the tank, through the

soakaway valve, to a downgradient practice. This practice is essential for helping to meet targeted storage volumes. The downgradient practice can be a simple stone-filled trench for small applications, or one of the other practices described below.

### Implementation

A standard construction sequence for a rainwater harvesting system installation is provided below. This can be modified to reflect different rainwater harvesting system applications or expected site conditions.

1. Choose the tank location on the site
2. Route all downspouts or roof drains to pre-screening devices and first flush diverters
3. Properly install the tank according to the manufacturer's recommendations, if applicable
4. Install the pump (if needed) and piping to end-uses (indoor, outdoor irrigation, or tank dewatering release)
5. Stabilize the overflow filter path with vegetation or appropriate lining.
6. Route all pipes to the tank. Stormwater should not be diverted to the rainwater harvesting system until the overflow filter path has been completely stabilized.

### Maintenance

Maintenance requirements for rainwater harvesting systems vary according to use. Systems that are used to provide supplemental irrigation water have relatively low maintenance requirements, while systems designed for indoor uses have much higher maintenance requirements. **Table 5.4** describes routine maintenance tasks to keep rainwater harvesting systems in working condition.

#### Other Recommended Guidance Documents

- 2020 Guidelines on Rainwater Catchment Systems for Hawai'i
- 2011 Cistern Water Quality Testing & Results in Coral Bay, St. John, US Virgin Islands
- EPA Fact Sheet: Cisterns in the USVI (2021)
- Keep Safe Guide: Guide for Resilient House Design in Island Communities (2019) - Chapter 5, Strategy 20 – Collect and Use Rainwater
- Centers for Disease Control and Prevention provides useful information on cleaning, disinfecting and maintaining cisterns

Table 5.4 Maintenance Guidelines for Rainwater Harvesting Systems

Activity	Frequency
Keep gutters and downspouts free of leaves and other debris	Twice a year
Inspect and clean pre-screening devices and first flush diverters	Four times a year
Operate soakaway valve for wet and dry season operation	Twice a year or more
Inspect and clean storage tank lids, paying special attention to vents and screens on inflow and outflow spigots. Check mosquito screens and patch holes or gaps immediately. Clean and flush the tank itself if needed	Once a year, prior to wet season
Inspect condition of overflow pipes, overflow filter path and/or secondary runoff reduction practices	Once a year
Inspect tank for sediment buildup	Every third year
Clear overhanging vegetation and trees over roof surface	Every third year
Check integrity of backflow preventer	Every third year
Inspect structural integrity of tank, pump, pipe and electrical system	Every third year
Replace damaged or defective system components	Every third year



## GREEN ROOFS

*Green roofs* are rooftop areas that have been landscaped with grasses, shrubs and, in some cases, trees. The two main types of green roofs are *intensive* and *extensive*.

Less commonly seen in the islands are green roof systems. Green roofs utilize a combination of vegetation and soils to reduce runoff volumes from small storm events through increased evapo-transpiration and filtration. Green roofs provide other benefits ranging from improved energy efficiency of buildings via insulation and cooling effects, to increased aesthetics and community open space.

“Intensive” rooftops are designed with pedestrian access and deep soil layers to provide for complex planting schemes. “Extensive” rooftops are designed with a more shallow soil foundation and generally do not incorporate pedestrian access. Stormwater runoff from small storms is retained until uptake can occur, while runoff from larger events is typically conveyed to downstream stormwater facilities for quantity control.



*This grass covered roof at a Guam hotel is aesthetically pleasing when viewed from windows of surrounding rooms.*

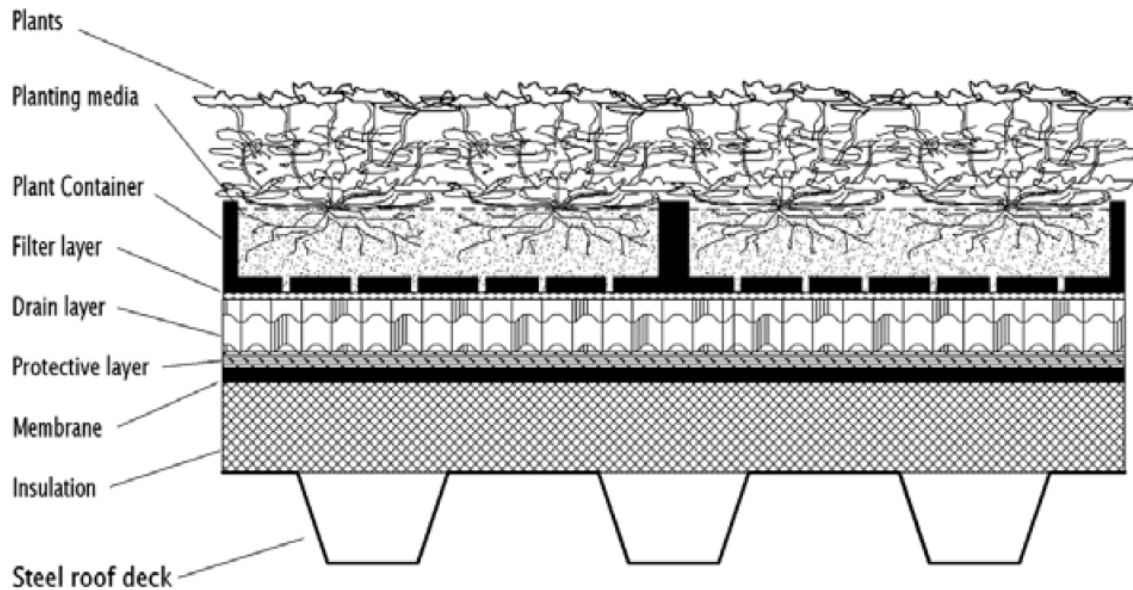

*Figure 5.3 Extensive Green Roof Construction Cross Section. Source: Wark and Wark, 2003 (originally from SHADE Consulting, LLC, 2003)*

## Feasibility

- Maximum 20% roof slope, unless specific measures are provided to retain the system on steeper slopes.
- Extensive: designed for maximum thermal and hydrological performance and minimum weight load and aesthetics.
- Intensive: designed with a deeper planting media, larger plants, and often incorporate public benches and walkways.

## Design

- The system shall have a maximum slope of 20%, unless specific measures from the manufacturer are provided to retain the system on steeper slopes.
- Green roofs can typically be used to meet runoff reduction and water quality treatment goals only, and are not appropriate for  $G_{p_v}$ , or  $Q_p$ .
- Extensive rooftops are commonly designed for maximum thermal and hydrological performance and minimum weight load while being aesthetically pleasing. Typically, only maintenance personnel have access to this type of roof. It can be installed on either a flat or pitched roof.
- Intensive rooftops are designed with a deeper planting media, larger plants (trees and shrubs), and often incorporate public walkways and benches. These are installed on flat roofs.

### Planting medium

Not to be confused with soil, the planting medium is distinguished by its mineral content, which is synthetically produced, expanded clay. The clay is considerably less dense and more absorbent than natural minerals, providing the basis for an ultra-lightweight planting medium. Perlite is a common form of expanded clay and is found in garden nursery planting mix (not planting soil). The types of expanded clays used in green roofs are also used in hydroponics.

### Filter layer

Between the planting media and drain layer lays a filter, which not only allows water to flow through while retaining the planting medium, but serves as a root barrier. The filter usually comprises one or two layers of non-woven geotextile, where one of the layers may be treated with a root inhibitor (i.e., copper or a mild herbicide). Extensive green roofs usually employ plants with easy-to-control roots, whereas



*This green roof over a residential garage on St. John shows that large vegetation can be supported if designed and maintained properly.*

intensive green roofs may contain deeper rooting plants requiring multiple filter layers. Since root and media particle diameters can vary, filters should be specified for different media and plant types to ensure adequate flow rates for a given planting mix without losing too much silt or allowing excessive root penetration.

### Containment

In modular systems, containment refers to actual plant containers. In non-modular systems, the planting medium is supported by the drain layer and contained at the perimeter by a metal or plastic barrier, or the roof parapet.

### Drain layer

Between the planting medium and roof membrane is a layer through which water can flow from anywhere on the green roof to the building's drainage system. Some systems simply use a layer of large-diameter expanded clay, but the preferred method is to use a corrugated plastic drain mat with a structural pattern resembling an egg carton or landscape paver. The minimum drain layer thickness is usually less than 20 mm (0.8 inches), but a thicker mat can provide additional insulation and root restriction.

The critical specification for a drain layer is the maximum volumetric flow rate, which is determined

based on the design precipitation of the 1-year design storm (runoff reduction) or just 1 inch for WQ<sub>v</sub>. Minimum passage area should be standardized for various locations. Since the drain layer supports the planting medium and vegetation, the compression strength should be specified. Many drain mat products are segmented or baffled to get the necessary compression strength, and hence, have insulating qualities that should be considered.

### **Protective layer**

The roof's membrane needs protection, primarily from damage during green roof installation, but also from fertilizers and possible root penetrations. The protective layer can be a slab of lightweight concrete, sheet of rigid insulation, thick plastic sheet, copper foil, or a combination of these, depending on the particular design and green roof application.

Since many building standards do not recognize the insulating qualities of green roofs, a local code variance may be needed to install one on an under-insulated roof. Rigid insulation can certainly be used as a protective layer. Insulation may be above or below the rigid roof surface.

### **Waterproofing**

A green roof can be installed with any kind of waterproofing system, but single-ply membranes have become very popular in recent years and are specified

by nearly all green roof companies for their cost effectiveness and simplicity. As such, the waterproofing layer is typically assumed to be a membrane.

A membrane is actually protected, not degraded, by a green roof. Without one, a membrane is subjected to UV radiation, extreme heat cycling, wind, rain, pollution (especially when ponding occurs), and damage from maintenance activities. With a properly designed green roof incorporating a protective layer, the membrane is subjected to nothing more than a small amount of moisture. Since a green roof keeps the membrane surface temperature much closer to the roof deck temperature, mechanical stress within the membrane is tremendously reduced. This helps maintain joint integrity, adherence to the deck, and reduces water vapor transfer.

The design criteria of the system should include provisions in case an exceptional situation develops, such as particularly invasive roots or excessive fertilizer from a rooftop garden. Here, an appropriate protective layer must be selected. Vegetation that can root through an undamaged, watertight membrane is rarely used in green roof construction. Some companies now offer membranes incorporating a layer of copper foil for added protection against root penetration. Existing standards and codes for membrane installation are more than sufficient for green roof applications.



*This green roof in American Samoa uses the same grass pavers used in the parking lot which were thought to be heavy enough to stay in place during heavy winds. Installed in conjunction with solar panels, the main function of this green roof is to improve efficiency of the buildings cooling system. This roof now provides a green place for staff to eat lunch.*

The only additional requirements might involve special provisions for inspection of a membrane before and after the subsequent green roof layers are installed.

### Vapor restriction

Since a green roof reduces the temperature gradients throughout the roof system, condensation is less likely to occur beneath the membrane. Situations requiring an additional vapor restricting sheet should be determined on an individual basis. (Wark and Wark, 2003)

### Conveyance

The runoff exceeding the capacity of the green roof system shall be safely conveyed to a drainage system or BMP without causing erosion. If an overland path is used, a stabilized channel shall be provided for erosive velocities (3.5 to 5.0 fps) for the 1-year storm event.

The green roof system shall safely convey runoff from the 100-year storm away from the building and into a downstream drainage system.

### Pretreatment

No pretreatment is required for direct rainfall.

### Treatment

Green roofs shall be designed to manage (i.e., without bypass to overflow) the  $WQ_v$ .

To account for the runoff reduction from green roofs in hydraulic and hydrologic models, designers may use a reduced CN. Intensive green roofs should use the runoff CNs for Woods, Brush, or Grass, depending on the specific plant communities used. Extensive green roofs should use the curve numbers listed in **Table 5.5** based on the thickness of the growing media.

Table 5.5 Effective Curve Numbers (CN) for Extensive Green Roofs (MDE, 2009)

	Growing Media Thickness (in.)				
	2	3	4	6	8
Effective CN	94	92	88	85	77

### Vegetation

Almost any plant can be put on a roof. The only limitations are climate, structural design and maintenance budgets. Since green roofs are typically lightweight, they often contain ground cover that can thrive in very shallow soils with little to no

maintenance. Sedum, a succulent ground cover, has become very popular for use on extensive green roofs. Also commonly used are a variety of hearty wildflowers and shallow-rooting grasses. Plant species for intensive green roofs can include trees and shrubs. At times, depending on the species and climate, it can be normal for rooftop vegetation to go dormant and lose foliage. Landscape design should specify proper plant species based on specific site, structural design, and hydric conditions present on the roof.

The ASTM E2400-06 Standard Guide for Selection, Installation, and Maintenance of Plants for Green Roof Systems covers the criteria considered for the selection, installation and maintenance of plants of a green roof system and applies to both intensive and extensive roof types. The primary considerations for plant selection are design intent, aesthetics, climate, plant characteristics including longevity, rate of establishment and pest resistance, and, media composition and depth. Also covered are installation methods including pre-cultivation (followed by transplant to the roof), direct seeding and seasonal issues (Halsall, 2007).

### Maintenance

Inspect green roof for leaks on a quarterly basis. Foreign matter, including leaves and litter, should be removed.

#### Intensive

Vegetation should be maintained as any other landscaped area, which may involve gardening and irrigation.

#### Extensive

- Vegetation may need to be watered periodically during the first season and during exceptionally dry periods.
- Vegetation may need to be lightly fertilized and weeded once a year.

## Green Roof Standards

The following ASTM Standards should be used for determining the appropriate planting medium and calculating the resulting loads on the roof (Halsall, 2007).

### *E2396-05 Standard Test Method for Saturated Water Permeability of Granular Drainage Media [Falling-Head Method] for Green Roof Systems:*

*This test method is used to determine the water permeability of coarse granular materials used in the drainage layer (100% of material retained on a 2.25 mm sieve) under low-head conditions typical of horizontal flow in green roofs. The method allows for direct comparison with alternative components, such as geocomposite drain layers. Also measured in the test is the wet density of the granular medium. The resultant water permeability is used to calculate the runoff coefficient.*

### *E2397-05 Standard Practice for Determination of Dead Loads and Live Loads associated with Green Roof Systems:*

*This method is used to predict the overall weight of a green roof system, including components typically encountered (membranes, non-absorptive plastic sheets, metallic layers, fabrics, geocomposite drain layers, synthetic reinforcing layers, protection boards, insulation, growing media, granular drainage media and plants. The procedure addresses the weight under two different conditions: 1) weight under drained conditions following rainfall or irrigation (including retained and captured water) and 2) weight during active rainfall when the drainage layer is completely saturated. The first condition is considered the dead load and the difference between the two conditions, approximated by the weight of transient water in the drainage layer is considered the live load. The procedure does not account for live loads associated with architectural elements, construction activities, or wind.*

### *E2398-05 Standard Test Method for Water Capture and Media Retention of Geocomposite Drain Layers for Green Roof Systems:*

*This method determines the water and media retention of synthetic drain layers used in green roof systems typically consisting of cup-like receptacles on the upper surface (shaped plastic membranes and closed-cell plastic foam boards). The standard does not apply to products manufactured from water-absorptive materials. The standard involves filling the drain layer with sand and water to determine the volume. To account for the difference in water capture depending on roof slope, the tests are performed under different inclinations of the drainage layer. The resultant water retention is used to calculate the runoff coefficient.*

### *E2399-05 Standard Test Method for Maximum Media Density for Dead Load Analysis of Green Roof Systems:*

*This test method is used to determine the maximum density of media used for dead load analysis. The method also provides a measure of the moisture content and the water permeability measured at the maximum media density. The procedure is suitable for media with less than 30% organic content. The test comprises of compressing moist media into a perforated cylinder using a Proctor hammer, immersed it in water and then determining the density and moisture content using standard gravimetric procedures. The sample is allowed to dry for 2 hours and is again measured to determine the maximum media density. The 2-hr value can be directly compared to media densities determined using the most common international procedures for establishing green roof dead load values.*



## INFILTRATION PRACTICES

Stormwater *infiltration practices* capture and temporarily store the  $WQ_v$  before allowing it to infiltrate into the soil over a maximum

period of 48 hours. Design variants include *Infiltration Basins, Infiltration Trenches, Underground Infiltration Chambers, and Dry Wells*. *Permeable pavements* are also infiltration practices, discussed in a section below.

Infiltration practices may not be able provide channel protection ( $G_{p_v}$ ) and/or overbank flood control ( $Q_p$ ) storage, except for some larger infiltration basin and chamber systems on sites where the soil infiltration rate is high (typically greater than 8.3 in/hr). For such high infiltration rates, or for practices located in bedrock rather than the soil profile, the infiltration practices can be used for *Runoff Reduction/Storage Only* for meeting the requirements for large storm events (i.e.,  $G_{p_v}$  and  $Q_p$ ), and not for meeting  $WQ_v$ . Otherwise, all other criteria in this section apply.

To assure that long-term infiltration rates are achieved, extraordinary care should be taken to protect the infiltration practice during construction and followed with adequate pretreatment and post-construction inspection and long-term maintenance. Clean roof runoff from non-hotspot sites can be infiltrated directly, without pretreatment, and counted toward both Runoff Reduction and  $WQ_v$  requirements.

### Feasibility

- In order to meet the water quality standard, the bottom of infiltration practices must be located in the soil profile (i.e., not bedrock).
- To be suitable for infiltration, underlying soils shall have an in-situ infiltration rate of at least 0.5 inches per hour, as initially determined from NRCS soil textural classification (see **Chapter 3** for a listing of V.I. soils and their hydrologic soil groups), and subsequently confirmed by on-site soil tests

(refer to **Chapter 3** for acceptable testing procedures). The minimum testing at the site of a proposed infiltration practice is one test hole per 5,000 ft<sup>2</sup>, with a minimum of one boring or test pit (taken within the proposed limits of the facility). However, for residential rooftop runoff, testing requirements are reduced to 1 infiltration test and 1 test pit per 5 lots assuming consistent terrain and within the same NRCS soil series. If terrain and soil series are not consistent, then requirements increase to 1 infiltration test and 1 test pit per 1 lot.

- The bottom of infiltration practices cannot be located in fill soils that form an unstable subgrade and are prone to slope failure. with the exception for strictly residential land uses, for which the bottom of practices may be located in up to 2 feet of fill consisting of material suitable for long-term infiltration after placement. Practices for non-residential sites that cannot be placed in natural soil may be designed as *filtering systems*. Such cases shall meet the media requirements of sand filters as described in **Section 5-3**.
- To protect groundwater from possible contamination, runoff from designated hotspots or activities shall not be directed to an infiltration facility.
- The bottom of the infiltration facility shall be separated by at least 2 feet vertically from groundwater and bedrock (when treating  $WQ_v$ ), as documented by on-site soil testing.
- Infiltration practices that are designed for the 10-year storm event or greater *and* have a separation from the bottom of the system to groundwater of less than four feet shall provide a groundwater mounding analysis<sup>2</sup>. Infiltration practices designed for residential rooftops  $\leq 1,000$  ft<sup>2</sup> are exempt from this.
- Infiltration practices cannot be placed in locations that cause water problems (such as seepage which may cause slope failure) to downgrade properties.
- The maximum contributing area to infiltration chambers and trenches should be less than 5 acres. The infiltration basin can receive runoff from

<sup>2</sup> The groundwater mounding analysis must show that the groundwater mound that forms under the infiltration system will not break out above the land or jurisdictional water. The

Hantush Method (Hantush, 1967) or other equivalent method may be used.

larger areas up to 10 acres. Drywells should generally receive runoff from areas less than 1 acre.

- Infiltration practices should not be used where subsurface contamination is present from prior land use due to the increased threat of pollutant migration associated with increased hydraulic loading from infiltration systems, unless contaminated soil is removed and the site is remediated, or if approved on a case-by-case basis.
- Infiltration facilities must meet the setbacks in **Table 5.6**.

### STORMWATER INFILTRATION PRACTICES FOR RECHARGE/STORAGE ONLY

On sites where the soil infiltration rate is high (greater than 8.3 in/hr) or the bottom of the practice is located in bedrock rather than the soil profile, infiltration practices cannot be used to treat the water quality volume. However, they may be used to provide runoff reduction, channel protection ( $G_p$ ) and/or overbank flood control ( $Q_p$ ) storage, but only AFTER treatment of 100% of the  $WQ_v$  prior to direct infiltration.

Table 5.6 Recommended Horizontal Setbacks from Infiltration Facilities (RIDEM and CRMC, 2015)

	Minimum Horizontal Setbacks	
	From small-scale facilities serving residential properties (ft)	From all other infiltration facilities (ft)
Public Drinking Water Supply Well – Drilled (rock), Driven, or Dug	200	200
Public Drinking Water Supply Well – Gravel Packed, Gravel Developed	400	400
Private Drinking Water Wells	50	100
Surface Water Drinking Water Supply Impoundment with Supply Intake	100	200
Tributaries that Discharge to the Surface Drinking Water Supply Impoundment	50	100
Coastal Features	50	50
All Other Surface Waters/Guts	50	50
Up-gradient from Natural slopes > %15	25	50
Down-gradient from Building Structures*	10	25
Up-gradient from Building Structures*	10	50
Septic Systems	15	25

\*Setback applies only where foundation is below the ponding elevation of the infiltration facility. Note that all foundations should be above groundwater.

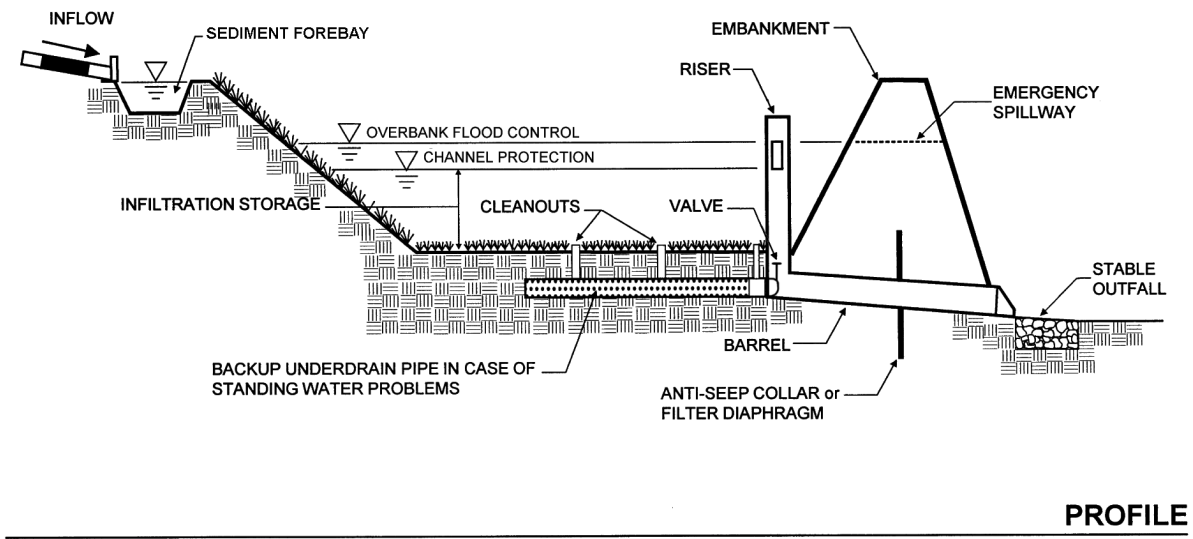
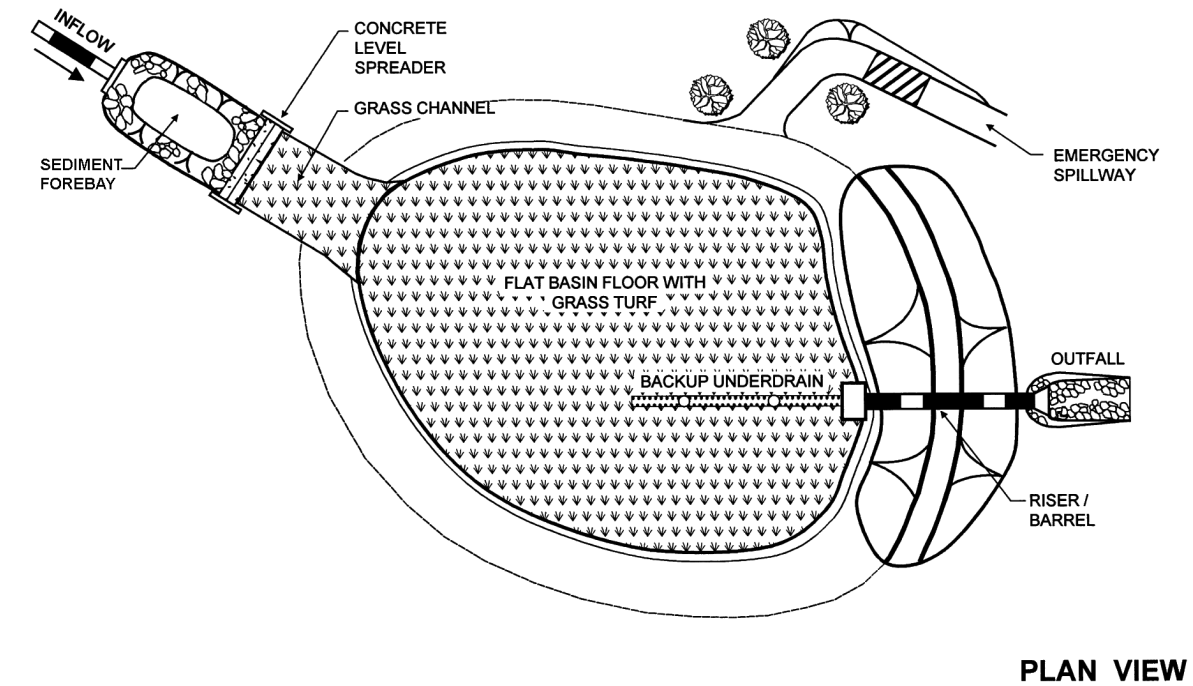

Figure 5.4 Example Infiltration Basin (from RIDEM and CRMC, 2015 – Adapted from MDE, 2000)



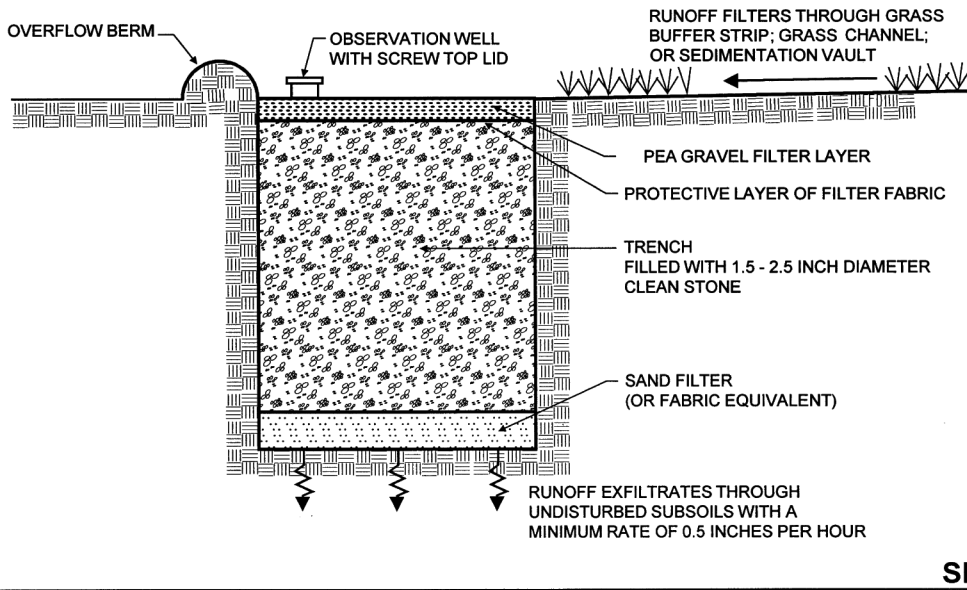
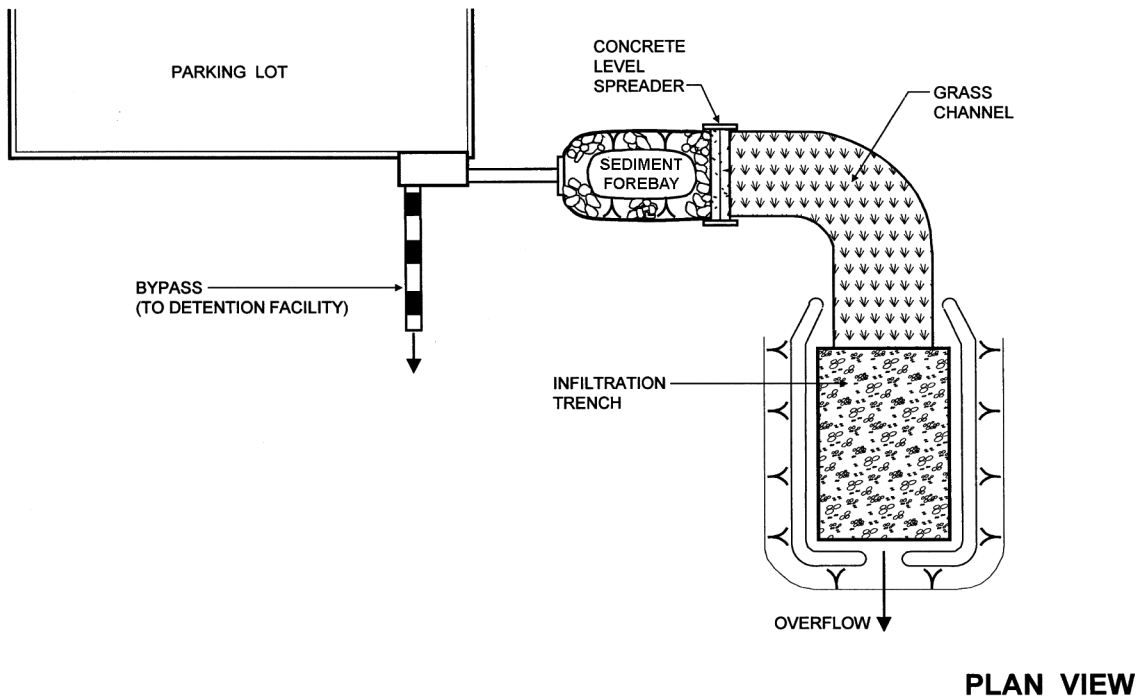

Figure 5.5 Example Infiltration Trench (from RIDEM and CRMC, 2015 – Adapted from MDE, 2000)

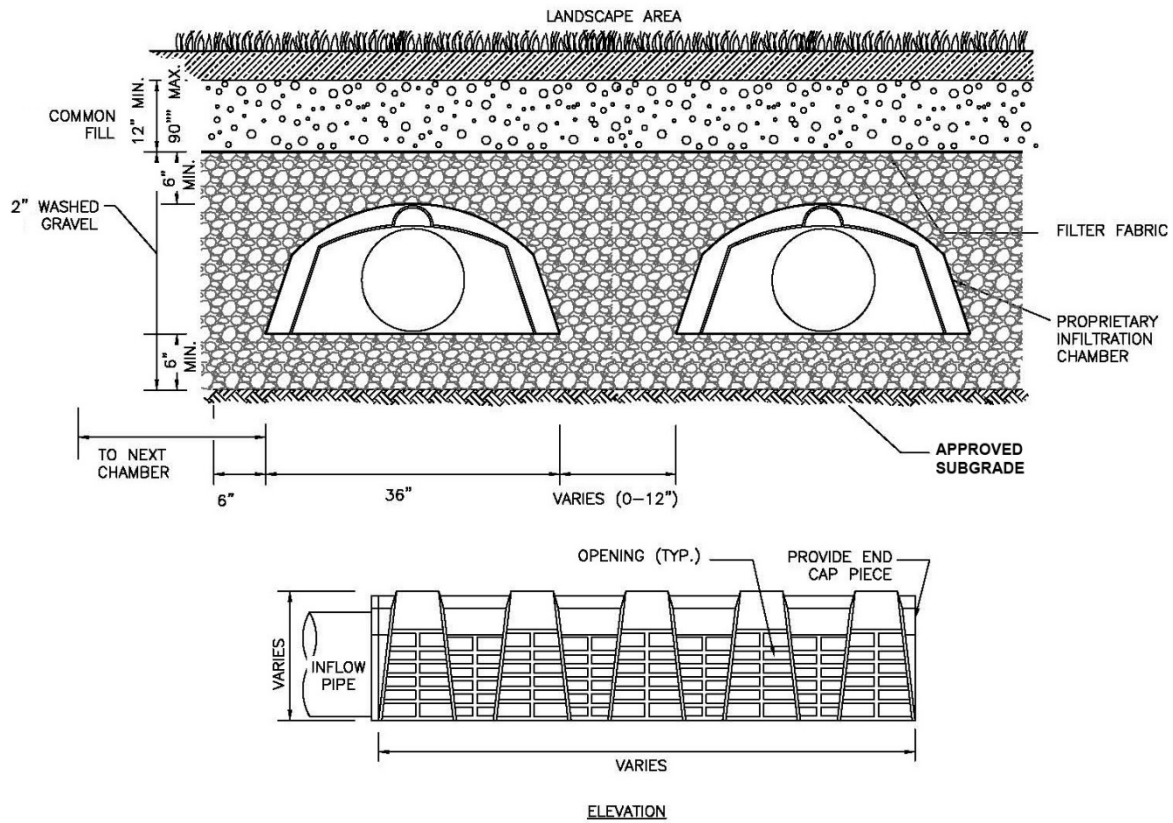

Figure 5.6 Example Underground Infiltration Chambers (from RIDEM and CRMC, 2015 – Adapted from MDE, 2000)

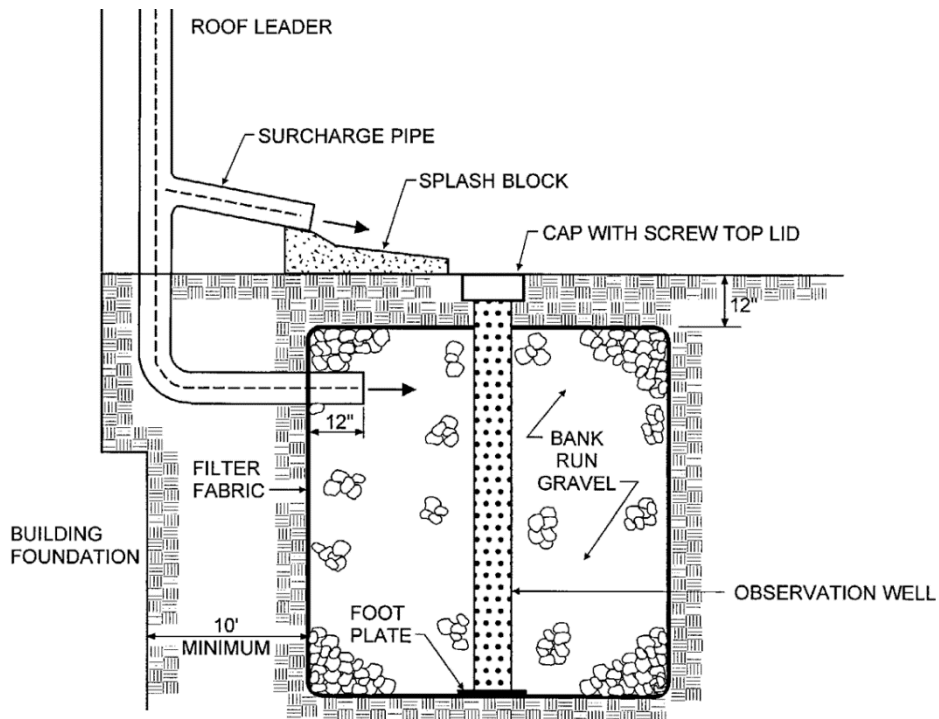

Figure 5.7 Example Dry Well (from RIDEM and CRMC, 2015 – Adapted from MDE, 2000)

## Minimum Plan Requirements

The following items must be shown on the design plans and/or included in the technical specifications:

- Location of all infiltration practices and components on the site plan
- Extra ESC measures to protect infiltration practice locations for sediment and compaction during construction
- Grading of surface infiltration practices
- Details showing practice materials and dimensions, and other key components
- Installation methods and sequencing
- Specifications for materials

## Conveyance

- Adequate stormwater outfalls shall be provided for the overflow associated with the 1-year design storm event (non-erosive velocities on the down-slope).
- The overland flow path of surface runoff exceeding the capacity of the infiltration system shall be evaluated to preclude erosive concentrated flow during the overbank events. If computed flow velocities exiting the system overbank exceed erosive velocities (3.5 to 5.0 fps) for the 1-year storm event, an overflow channel and/or level spreader shall be provided.
- All infiltration systems shall be designed to fully de-water the entire  $WQ_v$  within 48 hours after the storm event.
- If runoff is delivered by a storm drain pipe or along the main conveyance system, the infiltration practice must be designed as an off-line practice, except when used exclusively to manage  $Gp_v$  and  $Q_p$  (see Chapter Seven).

## Pretreatment

- For infiltration basins, chambers, and trenches, a minimum pretreatment volume of at least 25% of the  $WQ_v$  must be provided to protect the long-term integrity of the infiltration rate.
- Exit velocities from pretreatment chambers flowing over vegetated channels shall be non-erosive (3.5 to 5.0 fps) during the 1-year design storm.

- The sides of infiltration chambers, trenches, and dry wells should be lined with an acceptable filter fabric that prevents soil piping.

## Treatment

- If the in-situ infiltration rate for the underlying soils is greater than 8.3 inches per hour, 100% of the  $WQ_v$  shall be treated by an acceptable water quality practice prior to entry into an infiltration facility.
- Infiltration practices shall be designed to exfiltrate the entire  $WQ_v$  through the floor of each practice (i.e., sidewalls are not considered in sizing), unless the depth is greater than  $\frac{1}{2}$  the square root of the bottom surface area.
- The construction sequence and specifications for each infiltration practice shall be precisely followed. Experience has shown that the longevity of infiltration practices is strongly influenced by the care taken during construction.
- Design infiltration rates ( $f_c$ ) shall be determined by using **Table 3.2**, or shall be determined by in-situ rates (using a factor of safety of 2 from the field-derived value) established by one of the approved methods listed in **Chapter 3** (rates derived from standard percolation tests are not acceptable).
- Infiltration practices are best used in conjunction with other practices, and often downstream detention is still needed to meet the  $Gp_v$  and  $Q_p$  sizing criteria.
- A porosity value ( $V_v/V_t$ ) of 0.33 should be used to design stone reservoirs for infiltration practices.
- The bottom of the stone reservoir should be completely flat or nearly so (i.e., 0.5% slope) in order that infiltrated runoff will be able to infiltrate through the entire bottom surface area.

One method to calculate the surface area of infiltration trenches is to use the following equation:

$$A_p = V / (nd_t + f_{ct}/12)$$

Where:

- $A_p$  = surface area at bottom of trench (ft<sup>2</sup>)
- $V$  = design volume (e.g., 1-yr or  $WQ_v$ ) (ft<sup>3</sup>)
- $n$  = porosity of gravel fill (assume 0.33)
- $d_t$  = trench depth (ft)
- $f_c$  = design infiltration rate (in/hr)
- $t$  = time to fill trench (hours) (assumed to be 2 hours for design purposes)

One method to calculate the design volume of manufactured infiltration chambers is to use the following equation:

$$V = L [(wdn) - (\#A_c n) + (\#A_c) + (wf_c t/12)]$$

Where:

- V = design volume (e.g., WQ<sub>v</sub>) (ft<sup>3</sup>)
- L = length of infiltration facility (ft)
- w = width of infiltration facility (ft)
- d = depth of infiltration facility (ft)
- # = number of rows of chambers
- A<sub>c</sub> = cross-sectional area of chamber (see manufacturer's specifications)
- n = porosity (assume 0.33)
- f<sub>c</sub> = design infiltration rate (in/hr)
- t = time to fill chambers (hours) (assumed to be 2 hours for design purposes)

One method to calculate the surface area of trapezoidal infiltration basins is to use the following equation:

$$A_b = (2V - A_t d_b) / (d_b - P/6 + f_c t/6)$$

Where:

- A<sub>b</sub> = surface area at bottom of basin (ft<sup>2</sup>)
- V = design volume (e.g., 1-yr or WQ<sub>v</sub>) (ft<sup>3</sup>)
- A<sub>t</sub> = area at the top of the basin (ft<sup>2</sup>)
- d<sub>b</sub> = depth of the basin (ft)
- P = design rainfall depth (inches)
- f<sub>c</sub> = design infiltration rate (in/hr)
- t = time to fill basin (hours) (assumed to be 2 hrs for design purposes)

## Vegetation

- Upstream construction shall be completed and stabilized before connection to a downstream infiltration facility. A dense and vigorous vegetative cover shall be established over the contributing pervious drainage areas before runoff can be accepted into the facility.
- Mow upland and adjacent areas and seed bare areas.

## Maintenance

Maintenance is perhaps the most important aspect to the long-term success of infiltration practices. They should be designed with maintenance in mind from the beginning, ensuring easy access to key components and available equipment for required maintenance tasks. Be sure to do the following:

- Infiltration practices shall never serve as a sediment control device during site construction phase. Great care must be taken to prevent the infiltration area from compaction by marking off the location before the start of construction at the site and constructing the infiltration practice last, connecting upstream drainage areas only after construction is complete, and the contributing

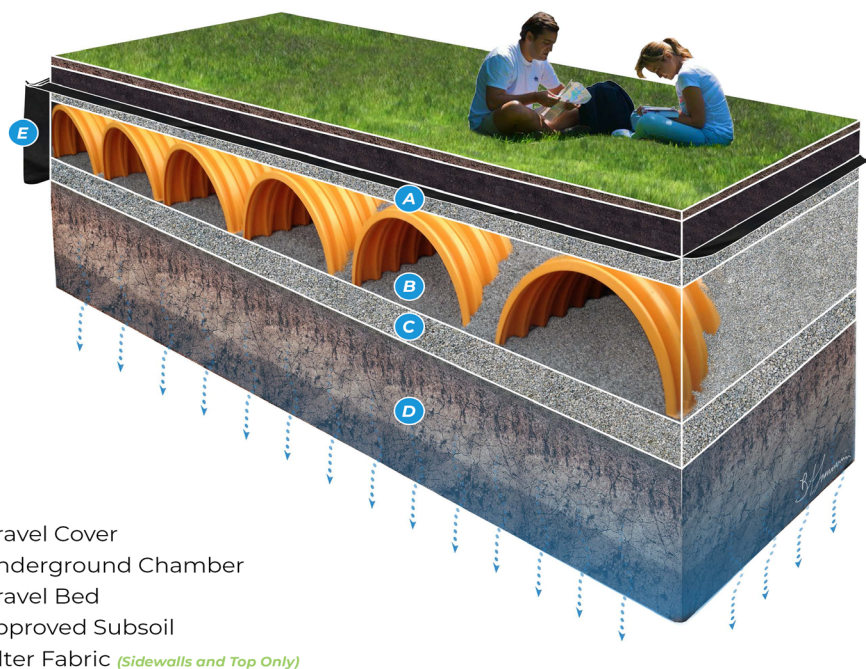

*Example of Underground Infiltration Chambers used below a ball field/park. Inspection ports are key for long-term maintenance.*

area is stabilized. In addition, the ESC plan for the site shall clearly indicate how sediment will be prevented from entering the site of an infiltration facility.

- An observation well shall be installed in every infiltration trench or chamber system, consisting of an anchored 4- to 6-inch diameter perforated PVC pipe with a lockable cap installed flush with the ground surface. The approving agency may require multiple observation wells for large underground chamber systems.
  - Infiltration practices shall be inspected annually and after storms equal to or greater than the 1-year storm event.
  - If sediment or organic debris build-up has limited the infiltration capabilities (infiltration basins) to below the design rate, the top 6 inches shall be removed and the surface rototilled to a depth of 12 inches. The basin bottom should be restored according to original design specifications.
  - OSHA trench safety standards should be observed if the infiltration trench will be excavated more than five feet.
  - Infiltration basin designs may include dewatering methods in the event of failure. Dewatering can be accomplished with underdrain pipe systems that accommodate drawdown as shown in **Figure 5.4**.
  - In the absence of evidence of contamination, removed debris may be taken to a landfill or other permitted facility. Any oil or grease found at the time of the inspection should be cleaned with oil absorption pads and disposed of in an approved location.
  - Preferably, direct access should be provided to infiltration practices for maintenance and rehabilitation. For trenches or chambers, which are used to temporarily store runoff prior to infiltration, the practice should ideally not be completely covered by an impermeable surface unless significant design constraints exist.
  - Surface infiltration practices should be mowed at least 2 times/yr. Stabilize eroded banks and repair eroded areas at inflow and outflow structures as necessary.

## PERMEABLE PAVEMENTS

Permeable pavements are a specific type of infiltration practice. These are good alternatives to conventionally-paved impervious surfaces, particularly for walkways, driveways, and low-volume roads and parking lots. Permeable surfaces allow stormwater to filter through voids in the pavement surface into an underlying stone layer, where it is temporarily stored and/or infiltrated. A variety of permeable pavement surfaces are available; including pervious concrete, porous asphalt, and many different types of pavers (Table 5.7). A prime advantage of permeable pavement is that it does not normally require additional space at a new development or redevelopment site, which can be important for tight sites or areas where land prices are high.

While the specific design may vary, all permeable pavements have a similar structure consisting of a surface pavement layer, a bedding layer, an underlying stone layer, a filter layer, geotextile installed on the sides, and sometimes, an underdrain in areas with poor soils. There are two major classes:

**Porous asphalt and pervious concrete.** Although they appear to be the same as traditional asphalt or concrete pavement, they have 10%-25% void space and are constructed over a base course that doubles as a reservoir for the stormwater before it infiltrates into the subsoil or is directed to a downstream facility.

**Pavers.** There are three typical paver configurations that are acceptable as runoff reduction SCMs. These are as follows:

- Permeable solid blocks or reinforced turf:** This type of permeable paving surface includes permeable solid blocks (where the blocks have a minimum void ratio of 15%) and contain open-cell grids filled with either ASTM No. 8 washed aggregate (for paving blocks) or sandy soil and planted with turf (for reinforced turf applications), set on a prepared base course consisting of a minimum of 1.5 inches of No. 8 washed aggregate, over a minimum of 4 inches of No. 57 washed stone. No. 2 washed stone is used as a reservoir course as necessary to manage variable storm sizes or provide other functions.

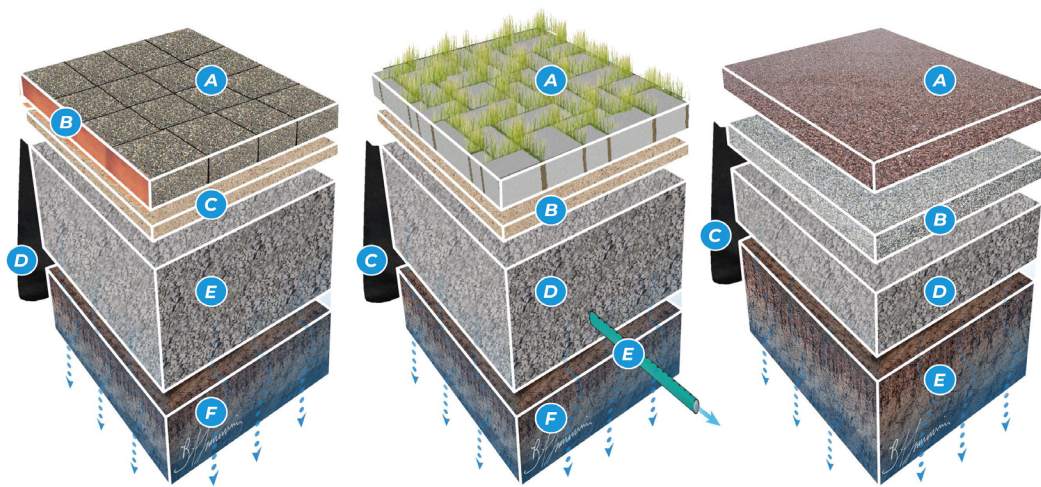

- |  |  |  |
|--|--|--|
| <b>A</b> Pervious Pavers                       | <b>A</b> Grass Pavers                          | <b>A</b> Porous Pavement                       |
| <b>B</b> Edging <i>(Per Manufacturer)</i>      | <b>B</b> Bedding Course                        | <b>B</b> Choker Course                         |
| <b>C</b> Bedding Course                        | <b>C</b> Filter Fabric <i>(Sidewalls Only)</i> | <b>C</b> Filter Fabric <i>(Sidewalls Only)</i> |
| <b>D</b> Filter Fabric <i>(Sidewalls Only)</i> | <b>D</b> Gravel Reservoir                      | <b>D</b> Filter Course                         |
| <b>E</b> Gravel Reservoir                      | <b>E</b> Perforated Underdrain                 | <b>E</b> Approved Subsoil                      |
| <b>F</b> Approved Subsoil                      | <b>F</b> Approved Subsoil                      |  |

*Example cross-sections of various permeable pavement options identifying the various design components.*

- Solid blocks with open-cell joints > 15% of surface:** This type of paver surface includes interlocking impermeable solid blocks or open grid cells that must contain permeable void areas (between the impermeable blocks) exceeding 15% of the surface area of the paving system. Permeable void areas are to be filled with ASTM No. 8 washed aggregate and compacted with a minimum 5,000 lbf plate compactor. Pavers are set on prepared base course materials consisting of a minimum of 1.5 inches of No. 8 washed aggregate, over a minimum of 4 inches of No. 57 washed stone. No. 2 washed stone is used as a reservoir course as necessary to manage variable storm sizes or provide other functions.
- Solid blocks with open-cell joints < 15% of surface:** This type of paver surface includes interlocking impermeable solid blocks or open grid cells that must contain permeable void areas (between the impermeable blocks) less than 15% of the surface area of the paving system. Permeable void areas are to be filled with ASTM No. 8 washed aggregate and compacted with a minimum 5,000 lbf plate compactor. In order to meet the runoff reduction requirements of Standard 2, these types of systems must be designed to provide a minimum of one inch of surface storage above the permeable pavement system. Pavers are set on prepared base course materials consisting of a minimum of 1.5 inches of No. 8 washed aggregate, over a minimum of 4 inches of No. 57 washed stone. No. 2 washed stone is used as a reservoir course as necessary to manage variable storm sizes or provide other functions.

There are two stormwater categories of permeable pavement that determine applicable design criteria:

- Infiltration Facility.** The base stores the target water volume and drains to underlying soil. These may not need perforated drain pipes at bottom of base; however, they may require overflow pipes for saturated conditions and large storms.
- Filter/Detention Facility.** This design includes an underdrain and an impermeable liner if needed at the bottom of the base aggregate. Runoff is directed to a downstream facility for additional storage as needed. This category is useful in sites with high groundwater, bedrock, hotspot, and

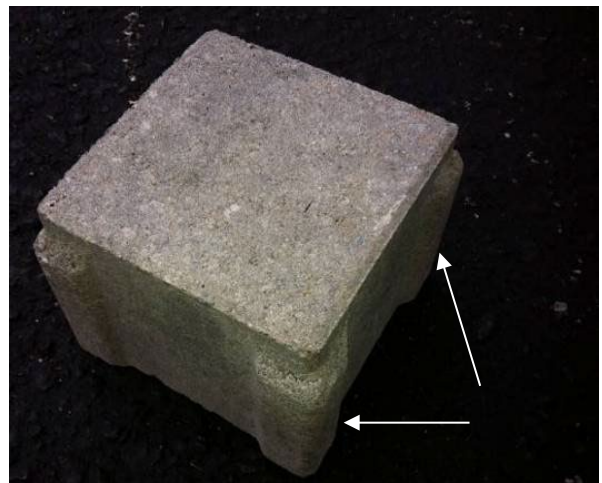









*Beveled spacers along the edges of paver blocks create the gaps between each interlocking concrete paver where water can infiltrate.*

areas with poor soils (an infiltration rate of less than 0.5-inch per hour). These designs still can incorporate some level of infiltration, especially during the dry season, by providing a stone “infiltration sump” and filter layer below the underdrain pipe. If designed as a filter/detention system, the infiltration restrictions noted in **Table 5.6** may not apply.



*Protect permeable pavements from sediment-laden run-on, particularly from erodible areas where vegetation has not yet established.*

Table 5.7 Typical Permeable Paving Materials

Type	Material	Application
Pervious Concrete		 <p>Mainland</p>
Porous Asphalt		 <p>Buzzards Bay, MA</p>
Concrete Grid Pavers (CGP)		 <p>Saipan, CNMI</p>
		 <p>Puerto Rico</p>



Type	Material	Application
<b>Permeable Interlocking Concrete Pavers (PICP)</b>		 <p data-bbox="1177 506 1365 537"><b>St. Croix, USVI</b></p>
		 <p data-bbox="1247 884 1362 915"><b>Oahu, HI</b></p>
<b>Plastic Grid Pavers</b>		 <p data-bbox="1133 1283 1354 1314"><b>St. Thomas, USVI</b></p>
		 <p data-bbox="1175 1707 1357 1738"><b>St. John, USVI</b></p>

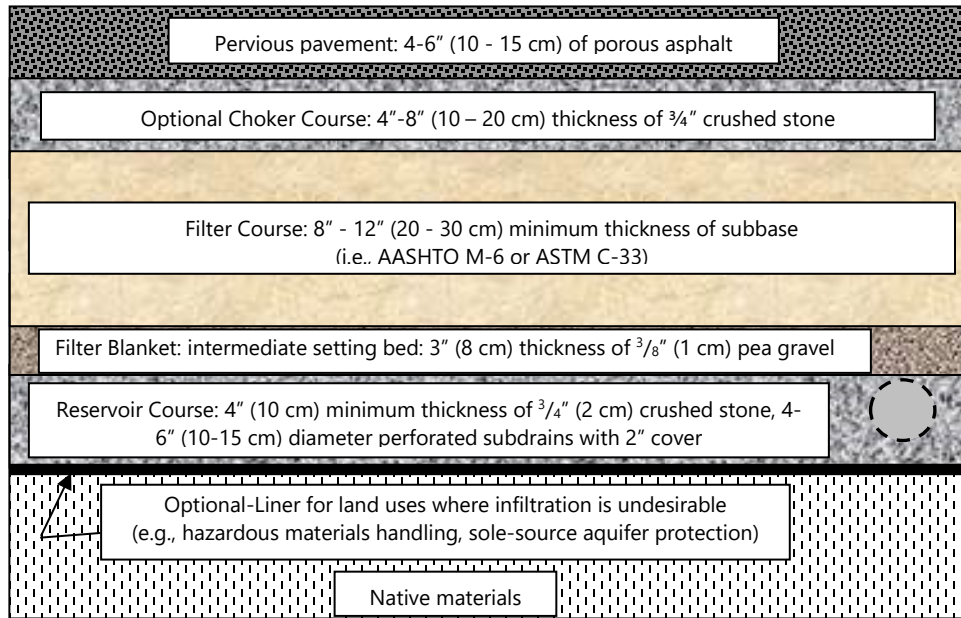

Figure 5.8 Example Cross-section of Porous Asphalt (UNHSC, 2009)

### Feasibility

- In order to meet the water quality standard, the bottom of infiltrating permeable pavement practices must be located in the soil profile.
- To be suitable for infiltration, underlying soils shall have an in-situ infiltration rate of at least 0.5 inches per hour, as initially determined from NRCS soil textural classification (see **Chapter 3** for a listing of V.I. soils and their hydrologic soil groups), and subsequently confirmed by on-site soil tests (refer to **Chapter 3** for acceptable testing procedures). The minimum testing at the site of a proposed infiltration practice is one test hole per 5,000 ft<sup>2</sup>, with a minimum of one boring or test pit (taken within the proposed limits of the facility).
- To protect groundwater from possible contamination, runoff from designated hotspot land uses or activities must not be directed to permeable pavement unless designed as a detention facility (with an impermeable liner).
- To avoid clogging issues and ensure long-term viability, permeable pavements are not permitted to receive runoff from other areas (i.e., they shall only be used to manage precipitation that falls directly on the permeable pavement area).
- The bottom of an infiltrating permeable pavement practice shall be separated by at least 2 feet vertically from groundwater or bedrock layer (when infiltrating), as documented by on-site soil testing.
- Groundwater elevation in the area of an infiltrating permeable pavement facility must be verified.
- Infiltrating permeable pavement practices must meet the setbacks in **Table 5.6**.
- The permitting agencies may reduce the minimum horizontal setbacks for infiltrating permeable pavements on a case-by-case basis in residential and non-vehicle surface (e.g., walkways/plazas) applications.
- This practice is not appropriate for high traffic/high speed areas ( $\geq 1,000$  vehicle trips/day) due to clogging potential.
- Use permeable paving **only on gentle slopes** (less than 5%). Permeable paving may be used on steeper slopes for other purposes such as stabilization, but not for meeting stormwater volume requirements.

***Do not use permeable pavements at pollution hotspots unless they are lined to prevent infiltration of contaminants into groundwater or include adequate pretreatment.***

- Typically, the pavement surface slope should be less than 1.0%. The bottom slope of a permeable pavement installation should be as flat as possible (i.e., 0% lateral slope) to enable even distribution and infiltration of stormwater. For applications on moderate slopes (e.g., up to 5%), designers should consider a terraced or cell design, either along the bottom grade (where the bottom layer meets the underlying soil), at the surface, or both. The objective is to maintain flat conditions where the bottom layer meets the underlying soil.
- Permeable paving surfaces are best used in low traffic areas such as overflow parking, residential driveways, sidewalks, plazas and courtyard areas. Areas with high amounts of sediment particles and high traffic volumes may cause system failures. Should not construct adjacent to areas subject to significant wind erosion.
- In general, permeable pavements should only be used to manage precipitation that falls directly on the permeable pavement area to protect the surface from clogging. Contributing drainage areas should be kept to a minimum (i.e., runoff from upgradient impermeable or permeable surfaces should be minimal).
- Location of permeable pavements near big trees can be an issue if excessive foliage dropping onto surfaces is crushed by tires into pavement void spaces. Keep vegetative maintenance in mind during the design phase.
- Permeable paving practices generally should be designed with an impermeable liner when used where subsurface contamination is present from prior land use due to the increased threat of pollutant migration associated with increased hydraulic loading from infiltration systems, unless contaminated soil is removed and the site is remediated, or if approved on a case-by-case basis.
- Details showing cross-sections, materials and dimensions, and other key components
- Installation methods and sequencing
- Identify stockpile areas and in maintenance specifications and contracts to prevent unintentional stockpiling on permeable pavement.
- Erosion and Sediment Control (ESC) measures to prevent sediment from entering the permeable pavement area and to keep heavy equipment from over-compacting soils, at a minimum. Permeable pavement areas should not be used as temporary sediment traps or basins during construction.

### Conveyance

All permeable pavement systems shall be designed to fully de-water the entire target volume (1-yr or WQ<sub>v</sub>) within 24 hours after the storm event.

Permeable pavement designs should include methods to convey runoff from large storms (e.g., greater than target storm event) to the storm drain system or directly into the storage reservoir below the permeable pavement. The following is a list of methods that can be used to accomplish this:

1. Set storm drain inlets up to 2" above the elevation of the permeable pavement surface (if inlets are not in the traffic flow path) to effectively convey excess stormwater runoff past the system.
2. Route excess flows to another detention or conveyance system that is designed for the management of extreme event flows.
3. Create additional underground detention within the stone reservoir layer of the permeable pavement system. Storage may be augmented by pipes, plastic or concrete arch structures, or similar structures.
4. Increase the thickness of the top of the stone layer by as much as 6 inches (i.e., create freeboard). The design computations used to size the stone layer assume that no freeboard is present. As this will make the system deeper, make sure to maintain adequate separations to water table and bedrock (see above).

### Minimum Plan Requirements

The following items related to permeable pavements must be shown on the design plans and/or included in the technical specifications:

- Location of all permeable pavement areas on the site plan



*Grass pavers installed at the new American Samoa Environmental Protection Agency office, one of the first LEED-certified buildings in the South Pacific. (photo: Brian Rippy)*

Any overland flow path of surface runoff exceeding the capacity of the permeable paving system shall be evaluated to prevent erosive concentrated flow during the overbank events. If computed flow velocities exiting the system over-bank exceed erosive velocities (3.5 to 5.0 fps), an overflow channel shall be provided to a stabilized watercourse.

Underdrains if needed should slope down towards the outlet at a grade of 0.5% or steeper. The up-gradient end of underdrains in the stone layer should be capped. Where an underdrain pipe is connected to a structure, there shall be no perforations within 1 foot of the structure. Ensure that there are no perforations in clean-outs and observation wells within 1 foot of the surface.

### Pretreatment

Pretreatment for most permeable pavement applications is not necessary since the surface acts as pretreatment to the stone layer below. Additional pretreatment may be appropriate if the pavement receives run-on from an adjacent pervious area. For example, a gravel filter strip can be used to trap coarse sediment particles before they reach the permeable pavement surface, to prevent premature clogging.

### Treatment

- Permeable pavements used as infiltration practices shall be designed to exfiltrate the entire target volume (1-yr or  $WQ_v$ ) through the floor of each practice (sides are not considered in sizing).
- Base course is a reservoir layer which shall be a minimum 6 inches, but is generally 12 to 24 inches or greater (function of storage needed). Base material must be poorly graded (uniform size material), must maintain adequate evaluate bearing capacity, depending on the use, and compaction effort must be adjusted to meet design storage requirements. Base course also includes a filter course above reservoir layer (2 to 6 inches of smaller material).
- The construction sequence and specifications for permeable pavement areas shall be precisely followed, particularly for infiltrating permeable paving practices. Experience has shown that the longevity of any infiltration practice is strongly influenced by the care taken during construction.
- For infiltrating permeable pavements, design infiltration rates ( $f_c$ ) should be determined by using **Table 3.2** based on the soil texture of the underlying soil. These are conservative values that take into account future clogging as the practice is used over the years.



At this installation in American Samoa, soil filled spaces between grass pavers were hollowed out for planting of individual plugs. Using the proper soil mix and providing irrigation helped establish vegetation quickly.

- For permeable paving practices used for detention only, no runoff reduction is allowed, i.e., impermeable CNs shall be used in hydraulic and hydrologic models when calculating  $G_p$  and  $Q_p$ , and the detention storage underneath the permeable paving practice shall be modeled separately.
- Permeable paving practices are best used in conjunction with other practices, and often downstream detention may still be needed to meet the  $Q_p$  sizing criteria.
- A porosity value ( $V_v/V_t$ ) of 0.33 shall be used to design stone reservoirs.
- For infiltrating permeable pavements, the bottom of the stone reservoir should be completely flat, or nearly so, in order that runoff will be able to infiltrate through the entire bottom surface area.

One way to calculate the surface area of infiltrating permeable paving surfaces is to use the following equation:

$$A_p = V / (n8d_t + f_c t / 12)$$

Where:

- $A_p$  = surface area (ft<sup>2</sup>)
- $V$  = design volume (e.g., 1-yr,  $WQ_v$ ) (ft<sup>3</sup>)
- $n$  = porosity of gravel fill (assume 0.33)
- $d_t$  = depth of aggregate base (ft)
- $f_c$  = design infiltration rate (in/hr)
- $t$  = time to fill (hours) (assumed to be 2 hours for design purposes)

To account for the runoff from infiltrating permeable paving materials in hydraulic and hydrologic models during large storm events when calculating  $G_p$  and  $Q_p$ , designers may use the runoff CNs listed in **Table 5.8**. CNs for infiltrating permeable pavements are a function of the depth of reservoir storage provided and underlying soils.

Table 5.8 Curve Numbers for Infiltrating Permeable Pavements (MDE, 2009)

Subbase (inches)	Hydrologic Soil Group			
	A	B	C	D
6	76	84	93	-
9	62	65	77	-
≥12	40	55	70	-

### Vegetation

- Other adjacent construction shall be completed and site stabilized before installation of reservoir materials. A dense and vigorous vegetative cover shall be established over any contributing pervious drainage areas before runoff can be accepted into the facility.
- Pavers that are planted with grass require species with deep root systems. Follow manufacturer's guidelines on appropriate species.

## Installation

Where possible, excavators should work outside the permeable pavement footprint area to excavate the underlying layers to their appropriate design depth and dimensions. This action will help to avoid compaction of underlying soils. Contractors can utilize a cell construction approach, whereby the proposed permeable pavement area is split into 500 to 1,000 sq. ft. temporary cells with a 10 to 15-foot earth bridge in between, so that cells can be excavated from the side. Excavated material should be placed away from the open excavation so as to not jeopardize the stability of the side walls. Paving materials should be installed in accordance with manufacturer or industry specifications for the particular type of pavement.

## Maintenance

Maintenance is a crucial element to ensure the long-term performance of permeable pavement.

- Areas where infiltrating permeable pavement practices are proposed shall not serve as a temporary sediment control device during site construction phase.
- Permeable paving surfaces require regular vacuum sweeping on a frequency consistent with the use and loadings encountered in the parking lot (minimum twice a year or as recommended by manufacturer) to keep the surface from clogging. The contract for sweeping should specify that a sweeper be used that does not use water spray, since spraying may lead to subsurface clogging. Any surface void material that is picked up or displaced during sweeping should be replaced with clean material.
- Do not repave or reseal with impermeable materials.
- Keep adjacent landscape areas well maintained and stabilized (erosion gully quickly corrected).
- Post signs identifying permeable pavement.
- Pavers planted with grass need mowing and often need reseeding of bare areas.
- Mow any upgradient contributing pervious drainage areas, and seed any bare areas.
- Monitor regularly to ensure that the paving surface drains properly after storms.
- Inspect the surface annually for deterioration or spalling.

- Avoid stockpiling construction materials on permeable pavement.

**Table 5.9** provides suggested annual maintenance inspection points to evaluate the condition and performance of the practice and remedial actions.

*Table 5.9 Maintenance Inspection Guidelines for Permeable Pavement Systems*

Inspection Activity	Remedial Action
Mow grass paver periodically to prevent overgrowth of vegetation (CGP, turf pavers)	Remove vegetation if blocking flow
Inspect surface for signs of surface clogging.	Vacuum sweep (no brooms or water spray) to remove deposited fines. For interlocking concrete pavement designs, it may be necessary to replace some of the pea gravel or sand between the blocks after vacuum sweeping.
Inspect the structural integrity of the pavement.	Replace or repair affected areas, as necessary.
Check inlets, pretreatment and flow diversion for sediment buildup and structural damage.	Remove sediment or repair affected areas.
Inspect contributing drainage area (CDA) for any sources of sediment or erosion.	Stabilize CDA or install sediment barriers to prevent run-on.
Measure drawdown rate in observation well after storms > 0.5 in.	Standing water after 3 days = clogging problem. Replace or repair affected areas.

## Troubleshooting

Permeable pavement technologies have come a long way in terms of performance, longevity, and costs. There are a few key design and installation issues, however, that can plague your system. Some of the big pitfalls to avoid include: designing a surface that accepts runoff from adjacent areas; compacting or clogging the system during construction; allowing for sloppy installation or inappropriate deviations from material specifications from suppliers; and failing to maintain the surface.

**Table 5.10** summarizes some of common things that go wrong and how to avoid or address the issues during design review, installation, and maintenance

phases of the project.

*Table 5.10 Tips to Avoiding Common Pitfalls*

What Goes Wrong	How to Avoid/Solve it		
	Design and Review Tips	Installation Tips	Maintenance Tips
1. Permeable surfaces clog during construction/installation	On plans, note that permeable structure should not be installed until the site is stabilized. Plan should show clear sequencing of tasks to avoid construction runoff onto permeable surfaces.	Divert construction runoff around installation area. If designed for infiltration, avoid compaction of area by heavy equipment.	Keep fines out of permeable surfaces with leaf blowers or vacuum sweepers. Avoid high pressure washers.
2. Contractor deviates from technical specs or installation procedures	Design for the materials you can get and/or provide list of approved equivalents. Be thorough in construction notes, particularly as relates to joint materials for pavers, and temperatures and size of pours (for porous concrete/asphalt).	<ul style="list-style-type: none"> <li>Use an experienced contractor where feasible</li> <li>Pour in small batches to ensure consistency and porosity (porous concrete/asphalt)</li> </ul>	Follow manufacturers' maintenance recommendations
3. Parking or travelways not designed for structural loads	Make sure the surface and subsurface designs are responsive to the anticipated structural loads, and not just storing the target volume(s) needed for meeting stormwater standards.	Conduct necessary structural load tests during installation.	Monitor structure integrity and check for settling and slumping. Make necessary repairs.
4. Run-on from adjacent areas leads to failure	Avoid designs that accept runoff from adjacent impervious cover (except for roofs). Permeable pavement systems should largely manage the rain that falls directly on its surface. Plan for pre-treatment if pervious areas drain onto permeable surfaces.	Make sure grading of adjacent areas is correct to avoid unintentional run-on	May require additional maintenance if run-on occurs
5. Structure does not drain quick enough to keep water off surface	<ul style="list-style-type: none"> <li>For infiltration designs, conduct a permeability (saturated hydraulic conductivity) test at the bottom elevation of the practice. If the rate is less than 0.5" per hour, consider a filter design with an underdrain.</li> <li>For filter/detention designs, ensure that underdrain sizes and slopes are suitable for wet season flows.</li> <li>For both types of design, provide an overflow structure about 2" above the pavement surface sized to handle expected flows from large storm events.</li> <li>An "overdrain" (perforated pipe) near the top of the stone layer, or other internal storage, can be used to ensure water will not pond on the pavement surface.</li> </ul>	<ul style="list-style-type: none"> <li>It is imperative to protect the soil during construction to prevent disturbance and compaction. Keep heavy equipment out of the area.</li> <li>Ensure that underdrains, overdrains, and internal storage layers are perforated, the right size, set at the right slope, and tie into the appropriate downstream structures.</li> </ul>	If water ponds on the surface for long periods of time, conduct an investigation to identify the problem. It may be possible to retrofit in some type of overdrain or overflow system.

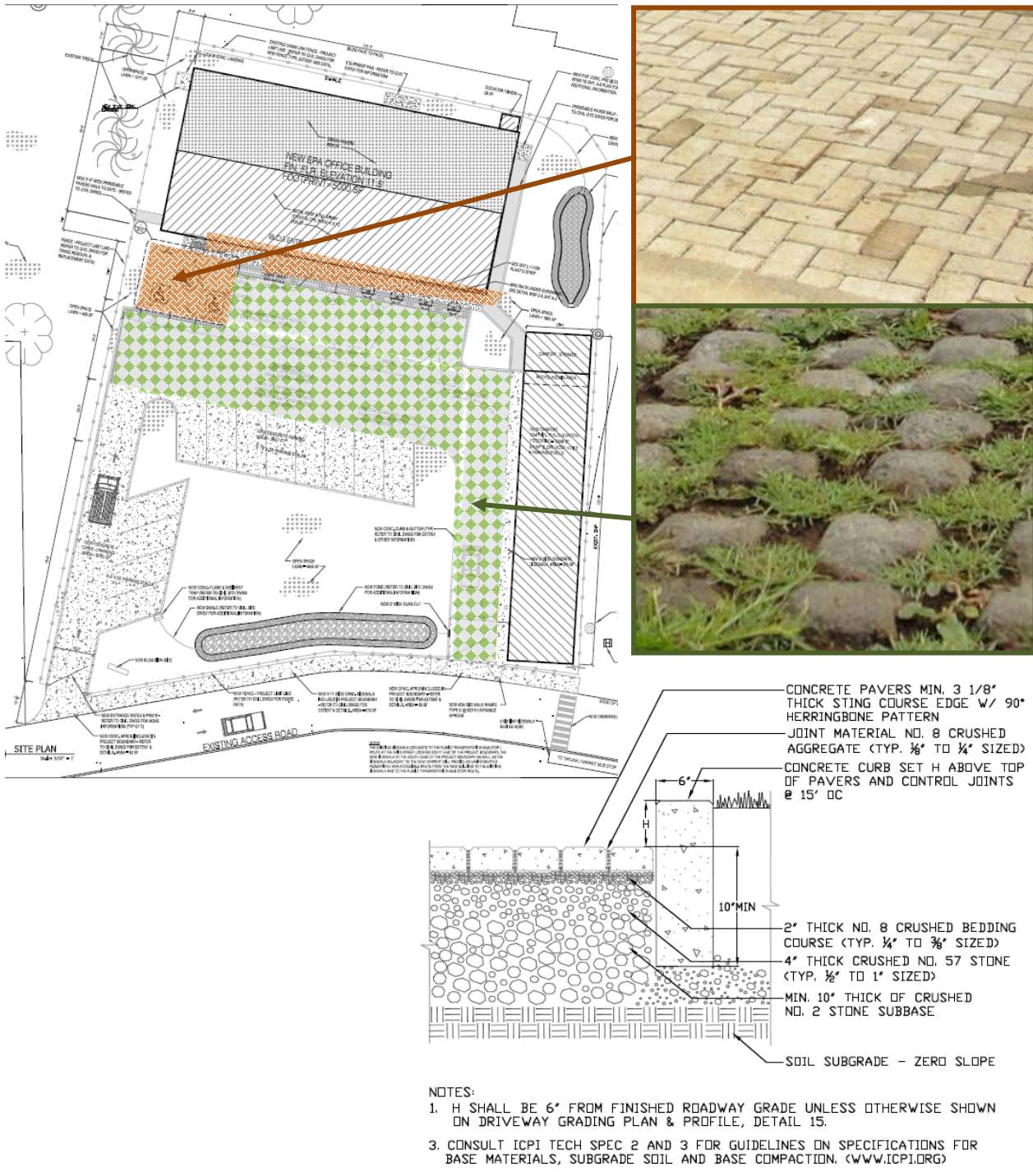

Figure 5.9 Excerpts from the American Samoa-EPA building construction plans show the locations of two types of permeable pavers and include a detail describing the type and depth of underlying aggregate.



### 5.3 WATER QUALITY TREATMENT PRACTICES

Water quality treatment practices are effective for removing pollutants from runoff to meet the requirements of the Water Quality Standard (SW 3) if the Runoff Reduction Standard (SW 2) cannot be fully met. Water quality treatment practices include filters as well as constructed wetland practices. If the filters are

designed to infiltrate, they can also be used to help meet SW 2. These SCMs can be incorporated into vegetated areas in creative ways that enhance the site.

The figures and photographs included in this section are schematic graphics only. Design plans should be consistent with the schematic figures when using the method or practice described, but must be completely detailed by the designer for site-specific conditions and construction purposes.

Table 5.11 Summary of water quality treatment SCMs and their typical relative benefits. Solid circles provide the benefit in most cases, while hollow circles provide the benefit in some cases.

Benefits	Filters			Constructed Wetlands		
	Bioretentions	Sand Filter	Dry Swale	Shallow Marsh	Gravel Wetland	Wet Swale
Reduces Runoff	○	○	○			
Easy to Install	○		●			●
Inexpensive	○		●	○		●
Good for Hotspots	○	○	○		○	
Aesthetics	●	○	●	●		
Habitat	●	○	○	●	●	●
Low Maintenance			○	●		●
Provides Large Storm Storage	○			●		



#### FILTERS

*Filtering systems* are typically landscaped areas with specific soil mixtures and native plants that are used to naturally filter stormwater runoff. Some

designs can infiltrate into the ground below, and others use underdrains to convey the treated water. Runoff from larger storms typically bypasses the practice and flows directly into the storm drain system and to a downstream storage SCM as needed.

There are several filter design variants that can be integrated into site pervious areas (see **Table 5.12**) including *bioretentions, rain gardens, stormwater planters, tree trenches, sand filters, and dry swales*. The different practices and variants provide an array of options that the designer can choose from based on the land use, treatment objective, and specific site constraints and features. Example plan and profile views for various practices are included in the figures below.

Rain gardens for small-scale single-family homes are much simpler than the engineered filters described here. See a rain garden guide for homeowners for more information on sizing and installing this simpler design.

Table 5.12 Typical Filter SCMs used for Water Quality

BMP		Applications	Example
Primary	<p><b>Bioretention</b>—vegetated depression with specific soil mix and structural components that may include an underdrain system, overflow structure, etc.</p>	<ul style="list-style-type: none"> <li>• Generally, used at commercial or institutional properties</li> <li>• Good for places where landscaped amenities are important</li> <li>• Can be designed for infiltration or filtering, depending on underlying soils</li> <li>• Flexible geometry – can be designed to fit the site</li> </ul>	
	<p><b>Rain Garden</b>—no underdrain, native soils, or only modest soil amendments</p> <p><i>*For residential applications only – design criteria not covered here. See rain garden guide for sizing</i></p>	<ul style="list-style-type: none"> <li>• Smaller-scale, for residential or small commercial properties</li> <li>• Good for managing roof runoff</li> <li>• If used for driveway and/or small parking lot runoff, maintenance may be higher due to greater pollutant load</li> <li>• Easy for homeowners to design and construct</li> <li>• Good for places where landscaped amenities are important</li> </ul>	
	<p><b>Planter Box</b>—elevated bioretention in a box</p>	<ul style="list-style-type: none"> <li>• Typically located at base of building downspout</li> <li>• Good for commercial developments where landscaped planters are already used</li> <li>• Many easy retrofits are possible at existing businesses and schools where downspouts already discharge into or near planters</li> </ul>	
	<p><b>Tree well or trench</b>—allow street trees and even sidewalks to do double-duty</p>	<ul style="list-style-type: none"> <li>• Typically in road ROW or along parking areas</li> <li>• Use curb inlets or curb cuts to direct runoff into tree pit with engineered soil mix for high filtration.</li> <li>• Overflows typically directed into existing storm drain system</li> </ul>	
Primary	<p><b>Dry swale</b>—long, skinny version of bioretention; can have longitudinal slope</p>	<ul style="list-style-type: none"> <li>• Can be used in road ROW, conveyance system, or parking lot medians</li> <li>• Maintenance is mainly mowing</li> <li>• Vegetation can be grass or landscaped similar to bioretention</li> </ul>	

Figure 5.10 Plan view (top) and longitudinal sections for a bioretention without (middle) and with (bottom) an underdrain



**BIORETENTION FACILITY DETAIL**  
NOT TO SCALE

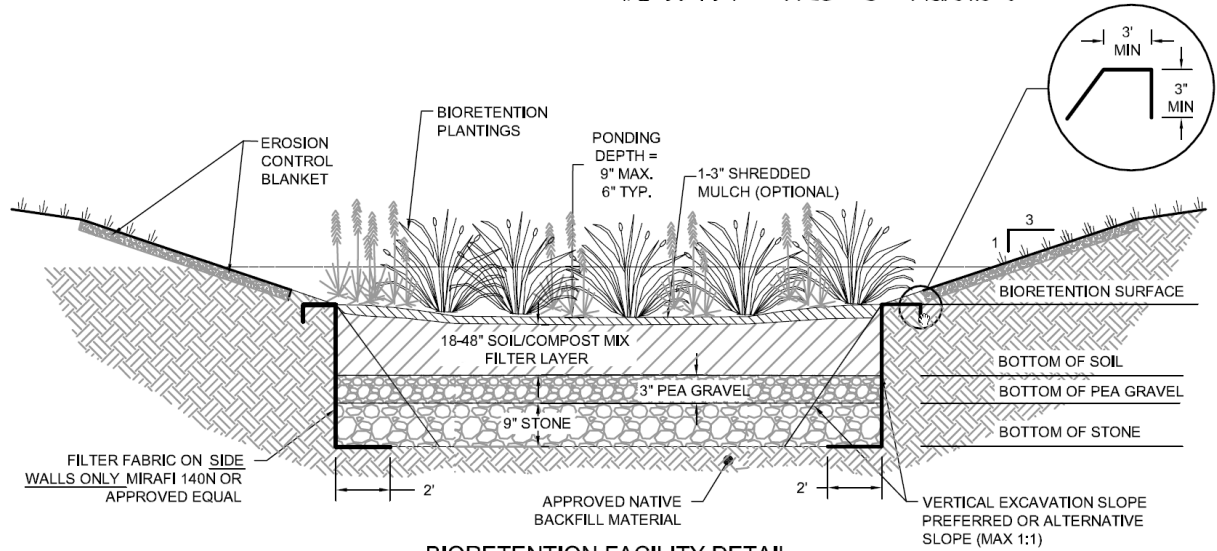
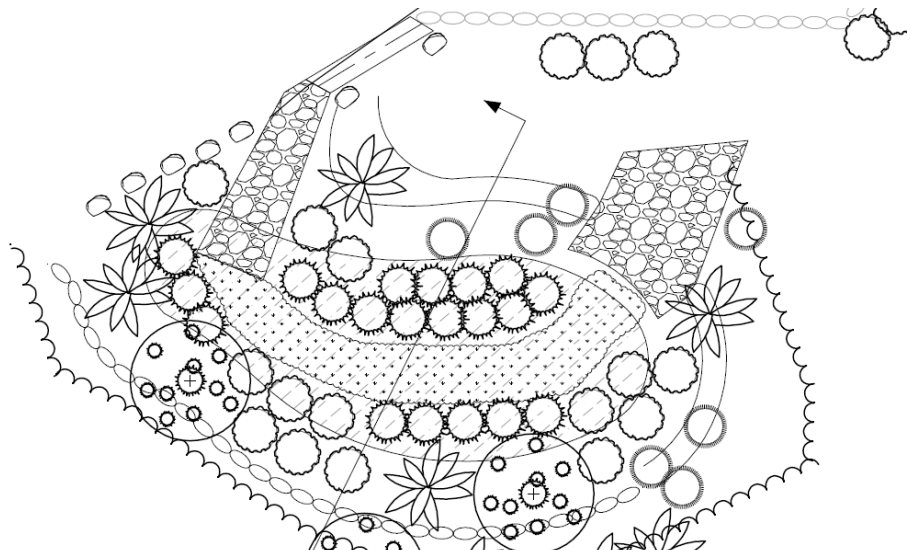
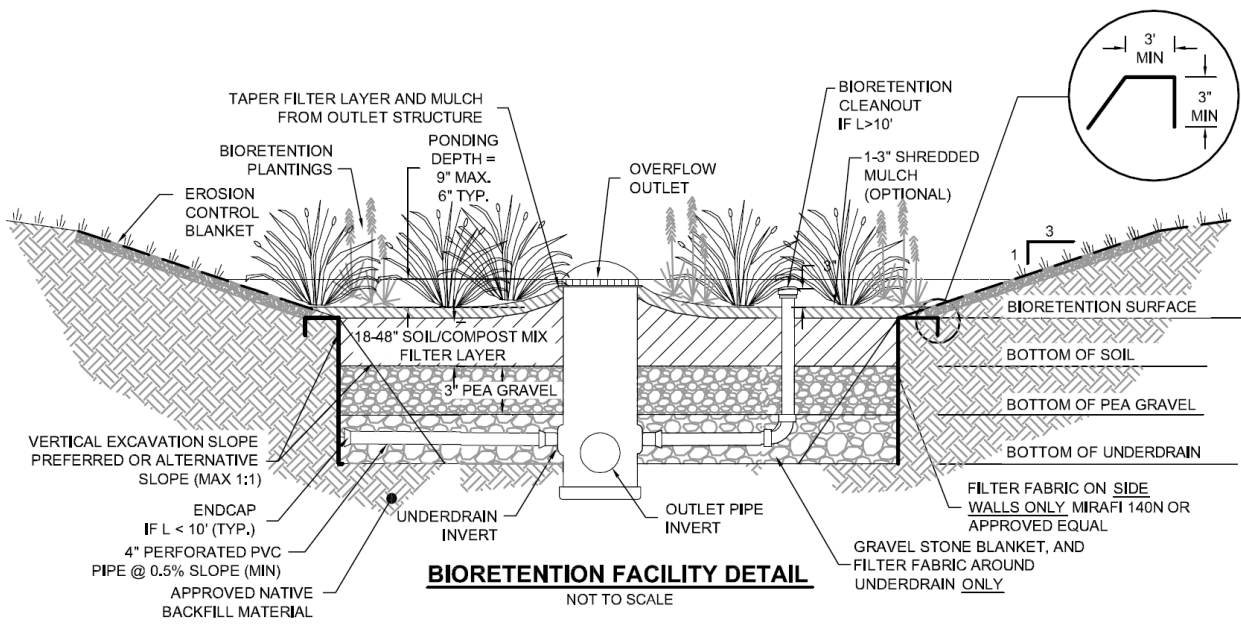

**BIORETENTION FACILITY DETAIL**  
NOT TO SCALE

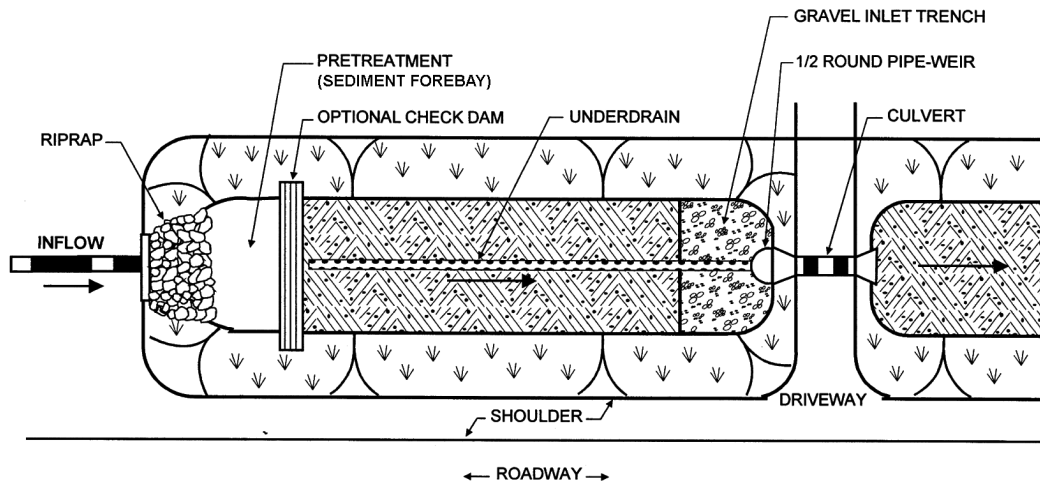

**PLAN VIEW**

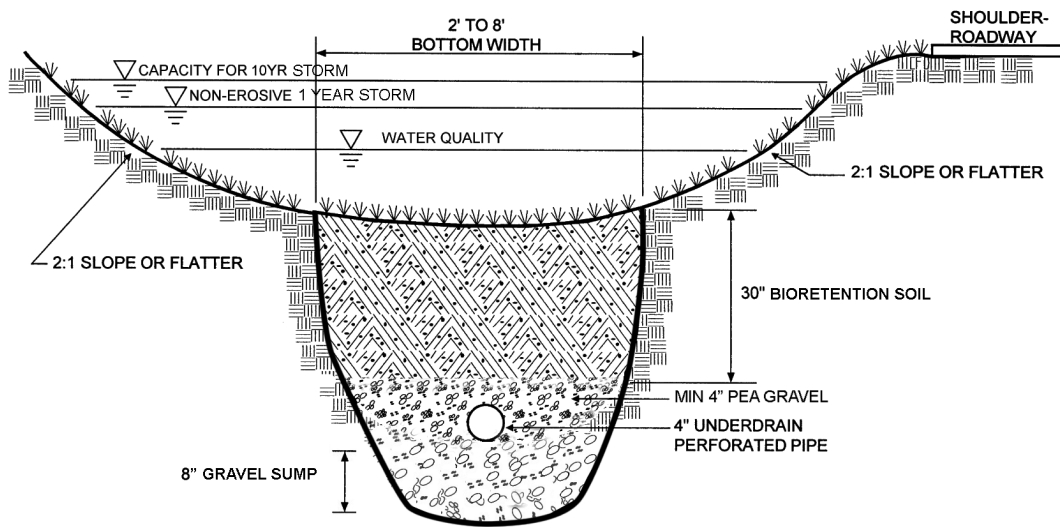

**SECTION**

Figure 5.11 Example of a dry swale with underdrain (from RIDEM and CRMC, 2015 – Adapted from MDE, 2000)

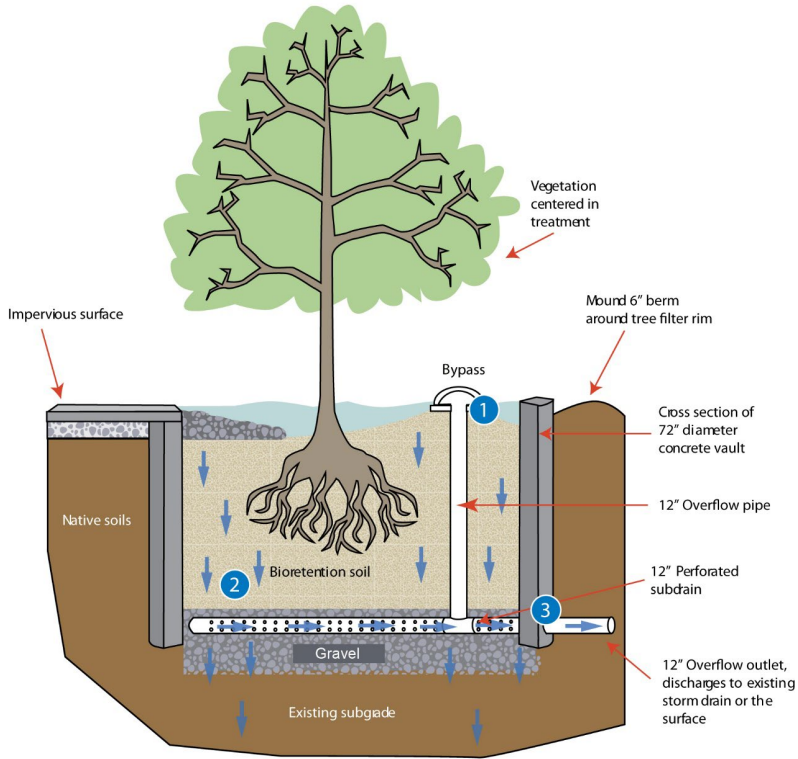
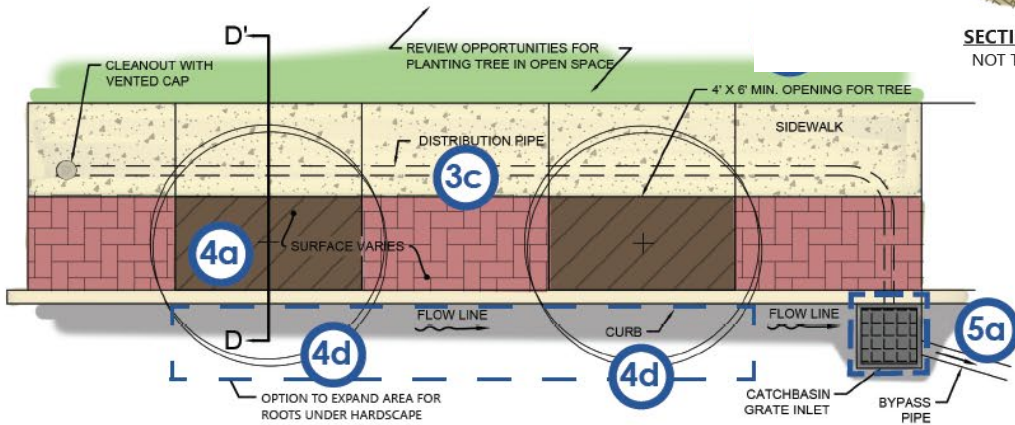
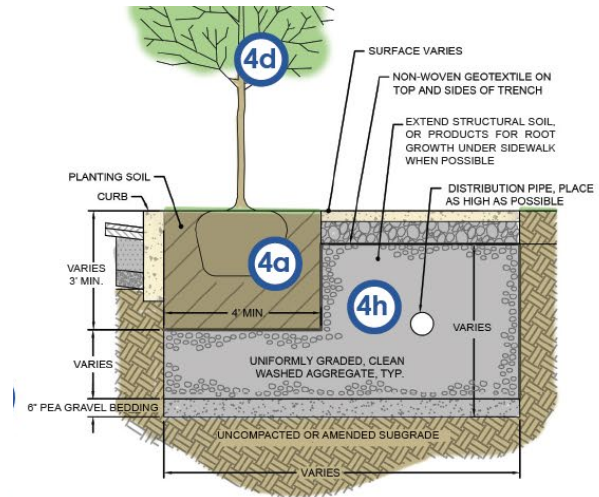

Figure 5.12 Example surface tree trench (above) (Source: adapted from UNHSC, 2007); Plan excerpt of a subsurface tree trench (right and bottom) (Stormwater Tree Trench Design Options Guide, 2021)



**TREE WELL**  
NOT TO SCALE

## Feasibility

- Filtering systems are extremely flexible designs that can be used for a range of land uses, constraints, and site configurations.
- The bottom of filtering systems shall be located at or above groundwater. The top of filtering systems shall be located at least 3 feet above groundwater.
- For filters that are designed to exfiltrate treated runoff into the underlying soils, design infiltration rates ( $f_c$ ) shall be determined by using **Table 3.2**, or shall be determined by in-situ rates (using a factor of safety of 2 from the field-derived value) established by one of the approved methods in **Chapter 3** (rates derived from standard percolation tests are not acceptable).
- Filters that cannot exfiltrate must have an underdrain system and may need to be lined.
- Unlined filtering systems greater than 1,000 sf in size shall not be located within 15 feet of any septic system.
- The recommended maximum contributing drainage area to an individual filtering system is usually less than 5 acres. In some situations, larger areas may be acceptable (e.g., design that has sufficient distance across entire surface area, multiple inflow locations, and bypass of larger storms).
- Tree trenches and stormwater planters are small bioretention practices that may be contained in a concrete vault with an underdrain connecting to the storm drain system, or may have an open base for infiltration into the underlying soils. All other design criteria and guidance for tree trenches and planters are identical to bioretention practices, excepting pretreatment<sup>1</sup>.
- Sand filtering systems are generally applied to land uses with a high percentage of impervious surfaces.

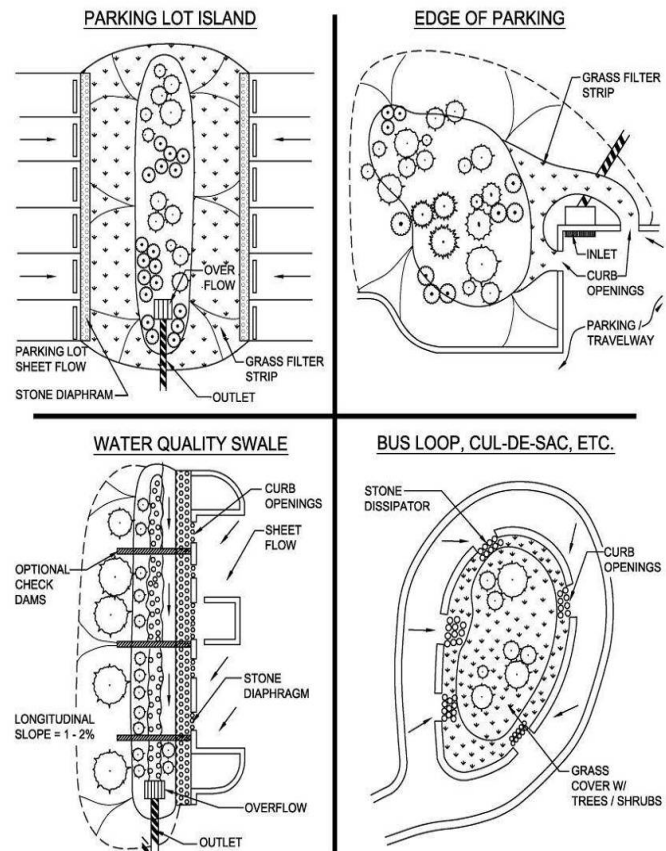

*Example filter applications in four different landscaped areas ranging from parking lots to turnarounds.*

- Dry Swales shall have a maximum longitudinal slope of 4%, without check dams.

## Conveyance

**Off-line vs. On-line** – There are two options for conveying water into the filter area: *on-line* and *off-line* systems.

In on-line systems, all the runoff volume is conveyed

<sup>1</sup> Decreased pretreatment is warranted in severely constrained site applications and where enhanced maintenance is assured (e.g., contracted landscaper).

into and through the filter. An overflow structure should always be incorporated into on-line designs to safely convey larger storms through the filter as needed.

The overflow structure shall be provided for runoff greater than the target volume (1-year or  $WQ_v$ ) up to the 25-year storm to a downstream storage practice if needed or to a non-erosive outlet point (i.e., prevent downstream slope erosion). Energy dissipators should be used as needed, such as rip-rap aprons or level spreaders (see **Chapter 4**). The overflow structure does not have to be in the filter bed itself, but can be at the edge of the filter bed or on the side slope.

An emergency overflow spillway shall be provided to safely direct runoff from the 100-year storm. In off-line systems, the flow is "split" up-gradient from the filter so that only design flows associated with the target volume enter the facility. This option is preferred, especially since wet season flows can easily surpass the treatment capacity of the filter area, and these flows can damage the inlet points, filter bed, and other components.

One common approach to split the flow is to create an alternate flow path at the inflow point into the structure such that when the maximum ponding depth is reached, the incoming flow is diverted past the facility (such as into a drop inlet in the adjacent parking lot). In this case, the higher flows do not pass over the filter bed and through the facility, but additional flow is able to enter as the ponded water infiltrates through the soil media.

Another way to split the flow, a flow regulator (or diversion structure) can be supplied to divert the target volume (1-year or  $WQ_v$ ) to the filter practice and allow larger flows to bypass the practice. This may be achieved with a weir, curb opening sized for the target flow, or a flow-splitting structure (for instance, in a catch basin or manhole), in combination with a bypass channel or pipe.

**Underdrain systems** - For filters with an underdrain, use a minimum 4" perforated pipe underdrain in a pea gravel layer, and an 8-12" gravel drainage blanket. Filter fabric should be used only on top of the portion of the pea gravel layer that is over the underdrain, 1'-2' either side and NOT across the whole filter bed. Synthetic filter fabrics should not be used to



*Tree trenches along walkways can help trees and improve water quality!*

completely separate the soil filter media from the underdrain bedding material. Experience has shown this to be a major source of failure for underdrained filters. Filter fabric is still recommended along the side walls.

Under drains should have a minimum slope of 0.5%, 3/8" perforations 6" on center, and ideally only have perforations on the lower half of the pipe. Depending on the width of the filter bed, multiple lines may be needed at 20' on center. The perforated pipe under the length of the filter bed should be connected with non-perforated pipe as needed to tie into the overflow structure/ storm drain system. Install T's and Y's as needed, depending on the underdrain configuration. Extend cleanout pipes to the surface with vented caps.

If designing an exfiltrating filter practice, an underdrain may not be necessary.

**Dry Swale Conveyance** - Peak velocity in a Dry Swale for the 1-year storm must be non-erosive (i.e., 3.5-5.0 fps). Dry Swales shall be designed to safely convey the 25-year storm.

### Pretreatment

- Pretreatment shall be provided at each parking lot, driveway, or road inlet into a filter practice equivalent to at least 10% of the  $WQ_v$ .
- Inlets from clean rooftops (i.e., downspout or dripline) do not require pretreatment.

### Treatment

**Volume** - The entire treatment system (including pretreatment) shall be sized to temporarily hold at least 75% of the  $WQ_v$ . A porosity value ( $V_v/V_t$ ) of 0.33 shall be used to account for storage within the filter media.

**Filter Bed** - Filters shall have a minimum 18" deep filter bed (depending on requirements of proposed vegetation). Bed depth may be reduced to 12" on a case-by-case basis as demonstrated by the designer that 18" is not feasible, such as sites with high groundwater or shallow depth to bedrock or clay soils, or in retrofit situations where pre-existing site constraints exist. In these cases, the required filter area shall be increased by 25%.

**Surface Ponding** - Bioretention and sand filter practices with surface ponding should include a 6" deep surface ponding area for the target volume, though a maximum of 9" below an overflow structure is allowed.

Dry swales should maintain a maximum ponding depth of one foot at the longitudinal mid-point of the channel, and a maximum depth of 18" at the end point of the channel for the target volume.

**Dry Swale Dimensions** - Swales shall be designed with a bottom width no greater than 8 ft to avoid potential gullying and channel braiding, but no less than 2 ft.

Dry Swales shall be designed with moderate side slopes (flatter than 3:1) for most conditions. Designers may utilize steeper side slopes if a hard material such as concrete curbing is used.



*Road rights-of-way are good places to install dry swales to help clean and infiltrate road runoff.*



*Don't let this clean rooftop runoff go to waste; if there isn't a cistern, direct it to a rain garden or bioretention without needing pretreatment.*



If the site slope is greater than 4%, additional measures such as check dams shall be utilized to retain the target volume (1-year or  $WQ_v$ ) within the swale system.

**Media** - Bioretention soil is used for all bioretention variants and Dry Swales and shall consist of USDA loamy sand to sandy loam classification and meet the following gradation as possible: sand 85-88%, silt 8-12%, clay 0-2%, and organic matter (in the form of leaf compost) 3-5%.

The filter media for a sand filter shall consist of a medium sand (meeting ASTM C-33 concrete sand).

**Filter Surface Area** - The minimum filter area shall be sized based on the principles of Darcy's Law. A coefficient of permeability ( $k$ ) shall be used as follows:

Bioretention soil:  $k=1.0$  ft/day for sandy-loam soils (used for dry swales as well)

Sand:  $k=3.5$  ft/day (City of Austin, 1988)

The minimum required filter bed area is computed using the following equation (City of Austin, 1988):

$$A_f = (WQ_v) (d_f) / [(k) (h_f + d_f) (t_f)]$$

Where:

$A_f$  = Surface area of filter bed (ft<sup>2</sup>)

$d_f$  = Filter bed depth (ft)

$k$  = Coefficient of permeability of filter media (ft/day)

$h_f$  = Average height of water above surface of practice (i.e., height above the uppermost mulch/organic layer) (ft)

$t_f$  = Design filter bed drain time (days)  
(2 days is the maximum  $t_f$  for bioretention)

In some cases, additional storage volume can be added along the edges of the main filter bed (see **Figure 5.13**).

**Modeling** - For designers using a TR-55 hydrologic/hydraulic model for filter facility sizing, an exfiltration "outlet" should be used with a constant velocity rate of exfiltration per **Table 3.2**. This rate is used in hydraulic routing to reflect the design infiltration rate when using NRCS methods where the vast majority of the runoff enters the system in just a few hours. Note that this is different from the hydraulic conductivity (e.g., for bioretention areas,  $k = 1$  ft/day as listed above vs. 2.41 inches/hr for loamy sand from **Table 3.2**) used in establishing the required minimum surface area, which is reflective of the long-term acceptance rate over a range of different storm intensities and durations with a 2-day drawdown.

### Vegetation

A dense and vigorous vegetative cover shall be established over the contributing pervious drainage areas before runoff can be accepted into the filtering facility.

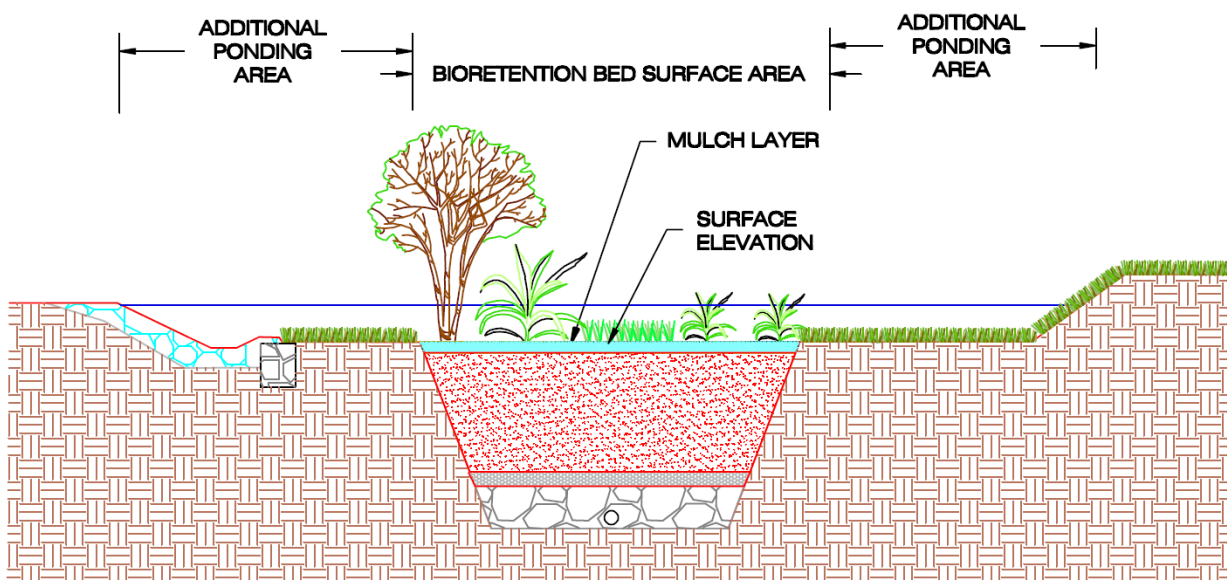

Figure 5.13 The storage volume for a filter practice can be increased by adding additional ponding area beyond the filter bed surface area, as long as the filter bed constitutes at least 75% of the total ponding surface area.

Vegetation is critical to the performance and function of vegetated filters; therefore, a planting plan must be provided that addresses the anticipated conditions (capable of withstanding frequent periods of inundation and drought, expected velocities in a dry swale). The permitting agency may require applicants to retain the services of a qualified professional with the educational background and/or experience to select appropriate plants.

Planting recommendations for filters are as follows:

- Native plant species should be specified over non-native species.
- Vegetation should be selected based on a specified zone of hydric tolerance and expected erosive velocities.
- Woody vegetation should not be specified at inflow locations.
- Trees should be planted primarily along the perimeter of the facility.
- A tree density of approximately one tree per 250 ft<sup>2</sup> (i.e., 15 ft on-center) is recommended. Shrubs and herbaceous vegetation should generally be planted at higher densities (5-10 ft on-center and 2.5 ft on center, respectively).
- Avoid using edible plants, particularly if drainage area is a parking lot or roadway that may contribute oils and other toxins to the runoff.
- Dry swales used for conveyance of larger storms should be planted with just grasses. Dry swales with low slopes and overflow structures for large storms can be planted similarly to bioretentions. Sometimes referred to as "bioswales."

**Mulch** - Mulch should be limited. Mulch floats and can cause clogging of overflow structures as well as add nutrients to the runoff in some cases. Mulch should be limited to the area right around root balls, and designers should consider seeding the filter bed instead of mulching. If seeded, filter should be kept "off-line" from stormwater runoff after construction until seed becomes established. Any mulch used should be weed-seed and pest free.



*Maintenance activities for vegetated filters include: watering after installation until plants are fully established and weeding, particularly during the first year.*

## Maintenance

Maintenance is a crucial element to ensure the long-term performance of filters. The most frequently cited maintenance problems are inlet clogging and erosion, sedimentation of the filter bed, and inadequate management of vegetation. Other than removing sediment and other trash, the main task that needs to be regularly performed is typical plant maintenance, such as removing dead or dying plant material, cutting back overgrown vegetation, and mulching occasionally to help prevent weeds and retain moisture. The following inspection and maintenance activities are typically required:

- During the six months immediately after construction, filter practices shall be inspected following at least the first two precipitation events of at least 1.0 inch to ensure that the system is functioning properly. Thereafter, inspections shall be conducted on an annual basis and after storm events of greater than or equal the 1-year event.

- Sediment shall be cleaned out of the pretreatment practice per those requirements in **Section 5.4**. Trash and debris shall be removed as necessary.
- Silt/sediment shall be removed from the filter bed when the accumulation exceeds one inch. When the filtering capacity of the filter diminishes substantially (i.e., when water ponds on the surface of the filter bed for more than 48 hours), the top few inches of discolored material shall be removed and shall be replaced with fresh material and replanted as needed.
- For unique installations in extremely tight sites or redevelopment/infill projects where pretreatment practices have been downsized, enhanced maintenance shall be required through more frequent inspections, more frequent sediment removal, and enhanced landscape maintenance.
- Filters that have a grass cover should be mowed as needed but not shorter than 4".
- Pruning or replacement of woody vegetation should occur when dead or dying vegetation is observed. Separation of herbaceous vegetation rootstock should occur when over-crowding is observed.
- Minor soil erosion gullies should be repaired when they occur. Eroded side slopes and filter beds shall be stabilized as necessary.
- During inspection, any structural components of the system, including trash racks, valves, pipes and spillway structures, should be checked for proper function. Any clogged openings should be cleaned out and repairs should be made where necessary.



## CONSTRUCTED WETLANDS

*Constructed wetlands* are engineered systems designed to imitate natural wetlands ability to improve water

quality by treating and containing stormwater runoff and pollutants and decreasing pollutant loadings to coastal waters. Constructed stormwater wetlands attempt to replicate all of the functions of natural wetlands and can be built as either *shallow constructed marshes, gravel systems*, or linear systems (*wet swales*).

### Feasibility

- Constructed wetland designs shall not be located within jurisdictional waters, including wetlands and guts.
- Constructed wetland designs specified to manage hotspot runoff require a separation (with liner) from groundwater. All other land uses do not require groundwater separation.
- The volume below the surface elevation of the permanent pool shall not be included in storage calculations for peak flow management ( $G_p/Q_p$ ).
- Assess the hazard classification<sup>1</sup> of the structure and consider alternative placement and/or design refinements to reduce or eliminate the potential for designation as a significant or high hazard dam.
- Setbacks for constructed wetland designs from septic systems shall meet relevant regulations.
- Wet Swales are constructed in groundwater. They shall have a maximum drainage area of 5 acres draining to any one inlet.
- Wet Swales shall have a maximum longitudinal slope of 4%, without check dams. If the site slope is greater than 4%, additional measures such as check dams shall be utilized to retain the water



*Example of a tropical wet swale design in Saipan.*

quality volume within a wet swale system.

However, Wet Swales typically need a longitudinal slope of <1% in order to maintain the required permanent pool volume.

- On-line Wet Swales shall be designed to safely convey the 25-year storm. Off-line Wet Swales should be designed for the target volume (1 yr or WQv).
- Wet Swales shall be designed with moderate side slopes (flatter than 3:1) for most conditions. Designers may utilize steeper side slopes if a hard material such as concrete curbing is used.
- Generally, shallow constructed wetland designs require a minimum drainage area of 10 acres to maintain a permanent pool, unless the practice intercepts groundwater. Likewise, a gravel constructed wetland design generally requires a minimum drainage area of 5 acres unless the practice intercepts groundwater.

### Minimum Plan Requirements

The following items must be shown on the design plans and/or included in the technical specifications:

- Location of all constructed wetlands on the site plan
- Grading plan showing constructed wetland contours and components

---

<sup>1</sup> "Hazard classification" is a rating for a dam that relates to the probable consequences of failure or misoperation based on an assessment of loss of human life and damages to properties or structures located downstream of an impoundment. A proposal to construct an impoundment

having a dam 6 feet in height or more, or a capacity of 15 acre-feet or more, or that is a significant or high hazard dam may subject the applicant to additional requirements in accordance with the Federal Dam Safety Program.

- Details showing inlet protection, outlet structure features and elevations, outlet protection, information on proposed berms/dams, and other key components
- Installation methods and sequencing
- Specifications for materials

## Conveyance

### Inlet Protection

- Flow paths from the inflow points to the outflow points of constructed wetland shall be maximized through the use of SCM geometry and features such as berms and islands.
- Inlet areas should be stabilized to ensure that non-erosive conditions exist for at least the 1-year frequency storm event.
- For a Shallow Constructed Marsh, inlet pipes should be set at the permanent pool or slightly above to limit erosive conditions. For a Gravel Constructed Wetland, inlet pipes may be set at the permanent pool or at the base of the gravel bed.
- Wet Swales may be designed as off-line systems to reduce erosion during large storm events.
- Wet Swales which directly receive runoff from non-roadway impervious surfaces may have a 6" drop.

### Adequate Outfall Protection

- The channel immediately below a constructed wetland outfall shall be modified to prevent erosion and conform to natural dimensions in the shortest possible distance, typically by use of appropriately sized riprap placed over filter cloth.
- A stilling basin or outlet protection shall be used to reduce flow velocities from the principal spillway to non-erosive velocities (3.5 to 5.0 fps).
- A subsurface water level must be maintained in the Gravel Constructed Wetland through the design of the outlet elevation (invert just below the surface). Care should be taken to not design a siphon that would drain the constructed wetland: the outlet invert location must be open or vented.
- Outfalls should be constructed such that they do not increase erosion by discharging at or near the gut water surface elevation or into an energy dissipating step-pool arrangement.

- If a constructed wetland discharges to a gut, care should be taken to minimize tree clearing along the downstream channel, and to re-establish a forested riparian zone in the shortest possible distance.
- The Gravel Constructed Wetland low-flow outlet structure should be based on a calculated release rate by orifice control to drain the  $WQ_v$  over 24 hrs. The practice may also have an additional orifice for draining the  $Gp_v$  over 24 hours.

### Constructed Wetland Liners

- When a constructed wetland is in soils with high infiltration rates and above the average groundwater table, an impermeable liner shall be used to sustain a permanent pool of water.
- No-geotextile fabrics are typically necessary within a constructed wetland but may be used to line walls of a Gravel Constructed Wetland.

## Pretreatment

Pretreatment shall be sized to contain a minimum of 10% of the  $WQ_v$ . The pretreatment storage volume counts toward the total  $WQ_v$  requirement.

Pretreatment shall be provided at each inlet, unless the inlet provides less than 10% of the total design storm inflow to the constructed wetland.

## Treatment

### Minimum Sizing Volume

- The surface area of a Shallow Constructed Marsh shall be at least 1.5% of the contributing drainage area; the Gravel Constructed Wetland surface area shall be at least 0.35% of contributing drainage area.
- For a Shallow Constructed Marsh: A minimum of 35% of the total surface area shall have a depth of 6 inches or less, and at least 65% of the total surface area shall be shallower than 18 inches. At least 10% of the  $WQ_v$  shall be provided in a pretreatment practice, and at least 25% of the  $WQ_v$  shall be provided in "deep water zones" with a depth equal to or greater than 4 feet. The remaining 65% of the  $WQ_v$  shall be provided in some combination of shallow permanent pool (depth less than 4 feet) and the extended detention (ED) storage volume above the permanent pool, as applicable. ED storage volume shall not exceed 50% of the  $WQ_v$  and shall drain over 24 hours.

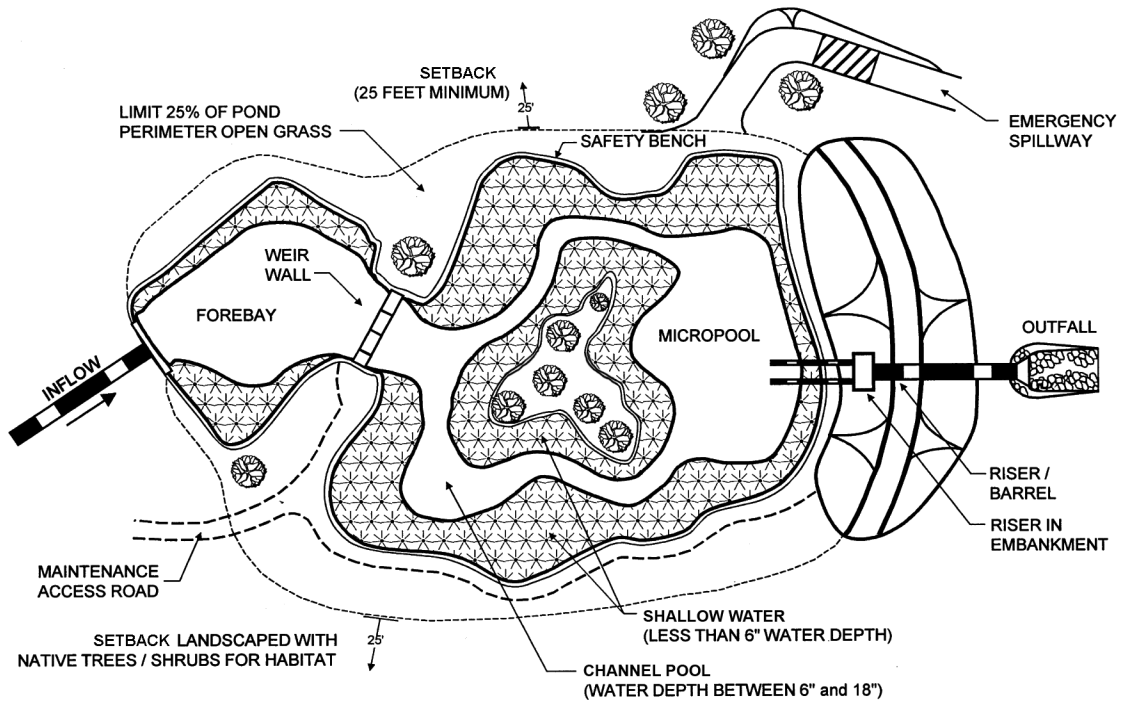

**PLAN VIEW**

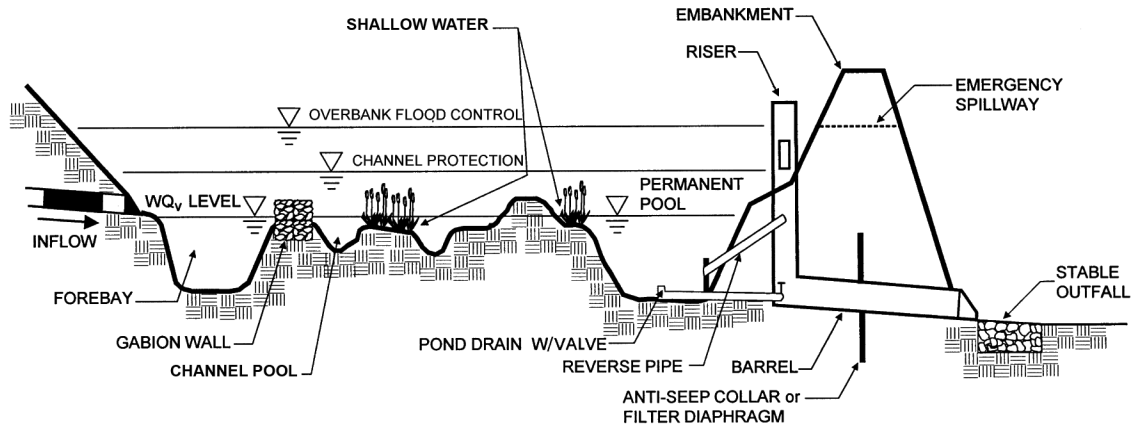

**PROFILE**

Figure 5.14 Example shallow constructed marsh (from RIDEM and CRMC, 2015 – Adapted from MDE, 2000)

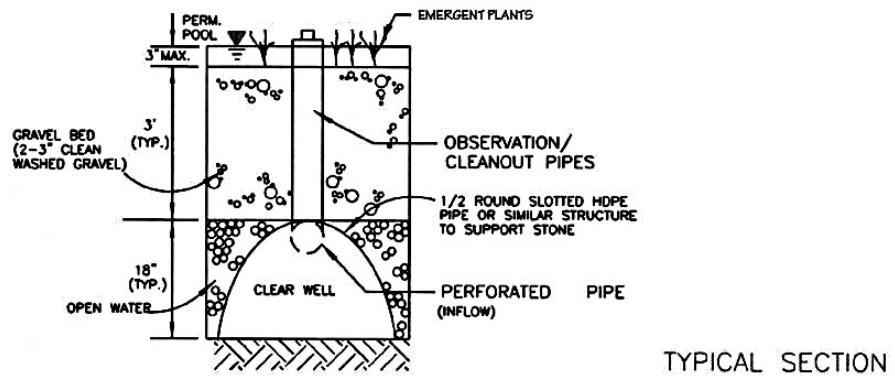
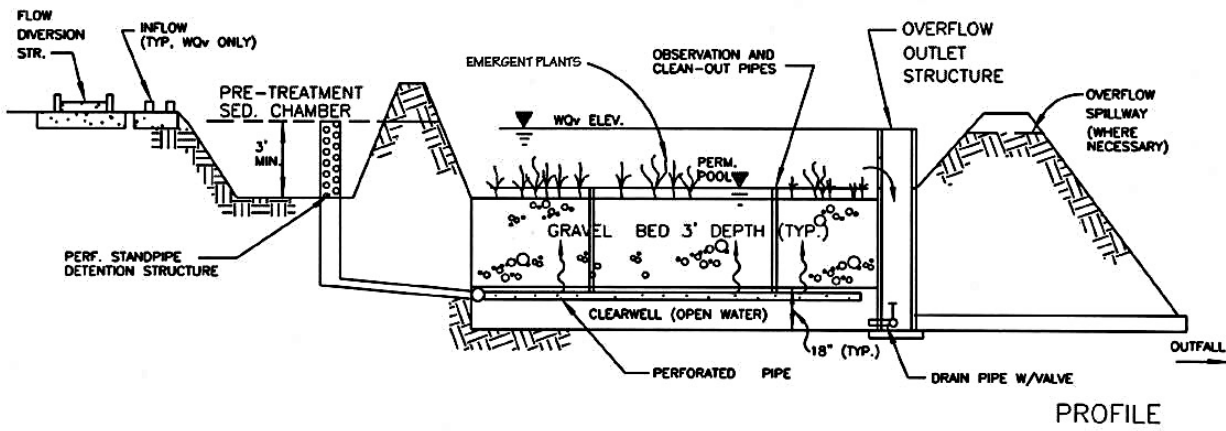
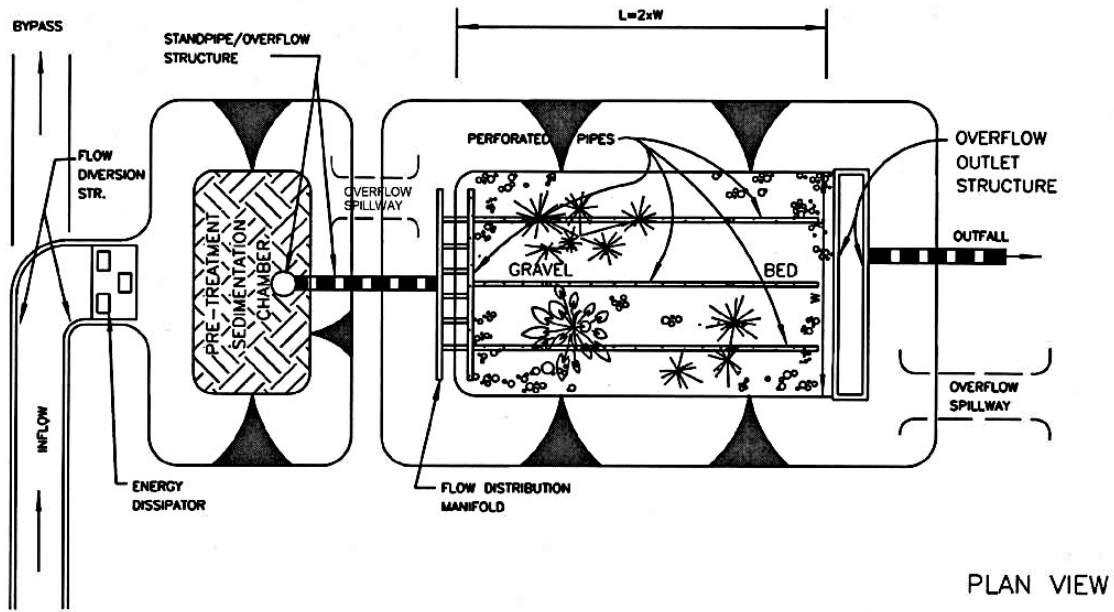
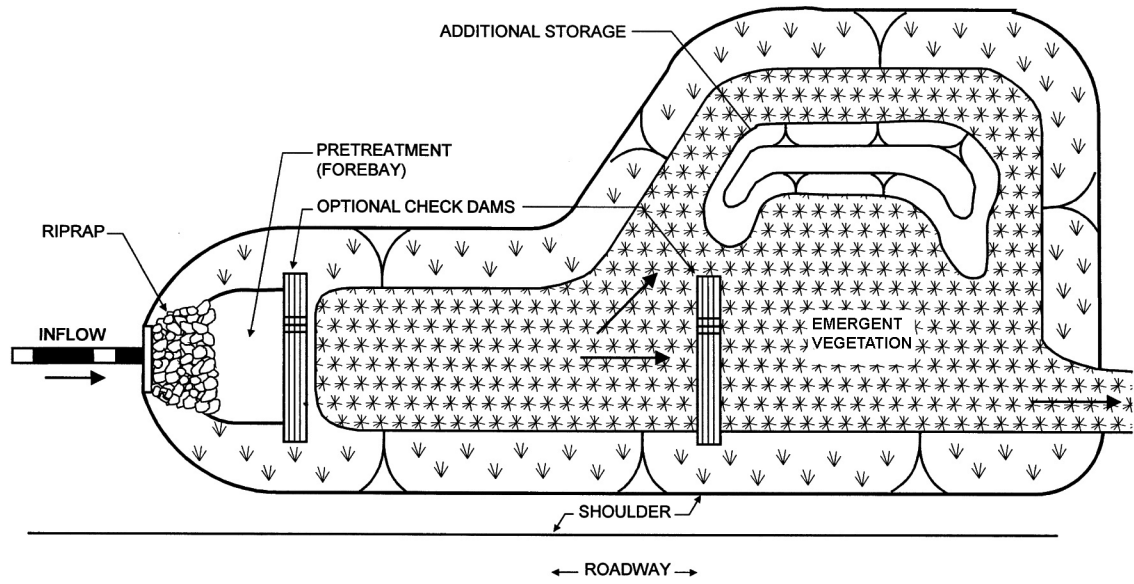
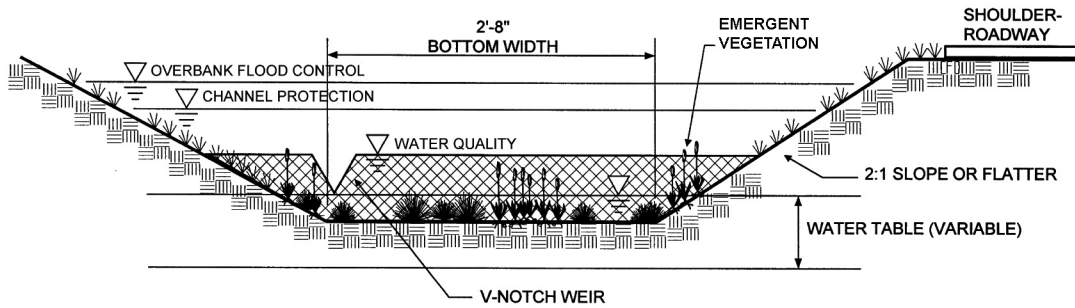

Figure 5.15 Example gravel constructed wetland (from RIDEM and CRMC, 2015 –Adapted from VTANR, 2002)



**PLAN VIEW**



**PROFILE**

Figure 5.16 Example Wet Swale (from RIDEM and CRMC, 2015 – Adapted from MDE, 2000)



- For a Gravel Constructed Wetland: At least 10% of the  $WQ_v$  shall be provided in a sediment forebay or other pretreatment practice. The remaining 90% of the  $WQ_v$  shall be provided in some combination of one or more basins or chambers filled with a minimum 24-inch gravel layer and the open, ED storage volume above the gravel, as applicable. ED storage volume shall not exceed 50% of the  $WQ_v$  and shall drain over 24 hours.
- For a Wet Swale: Wet swale length, width, depth, and slope shall be designed to temporarily accommodate the target volume (typically,  $WQ_v$  to meet SW 3) through surface ponding.
- It is generally desirable to provide water quality treatment off-line when topography, head, and space permit, particularly for the Gravel Wetland and Wet Swale. A Shallow Constructed Marsh is often sized as an on-line practice with storage for large storm events.
- Water quality storage can be provided in multiple cells. Performance is enhanced when multiple treatment pathways are provided by using multiple cells, longer flow paths, high surface area to volume ratios, complex microtopography, and/or redundant treatment methods (combinations of pool, ED, and emergent vegetation).
- The permanent pool may be included in water quality volume calculations.

- For Gravel Constructed Wetland, a layer of organic soil may be used as substrate for emergent vegetation but is not necessary depending on chosen species. If an organic soil layer is used as a top layer, it should have a minimum thickness of 8", should be leveled (constructed with a surface slope of zero), and should be underlain by 3" minimum thickness of an intermediate layer of a graded aggregate filter to prevent the organic soil from moving down into the gravel sublayer.

### Minimum Constructed Wetland Geometry

- Flow paths from the inflow points to the outflow points of constructed wetland shall be maximized through the use of SCM geometry and features such as berms and islands.
- The minimum length to width ratio for a Shallow Constructed Marsh is 2:1 (i.e., length relative to width). However, to the greatest extent possible, maintain a long flow path through the system, and design with irregular shapes. A more traditionally shaped (oval or rectangular) basin may be permitted when conditions such as topography, parcel size, or other site conditions warrant. These marshes shall follow natural landforms to the greatest extent possible or be shaped to mimic a naturally formed depression.
- For a Gravel Constructed Wetland: length to width ratio of 1:1 (L:W) or greater is needed for each treatment cell with a minimum flow path (L) within the gravel substrate of 15 feet.

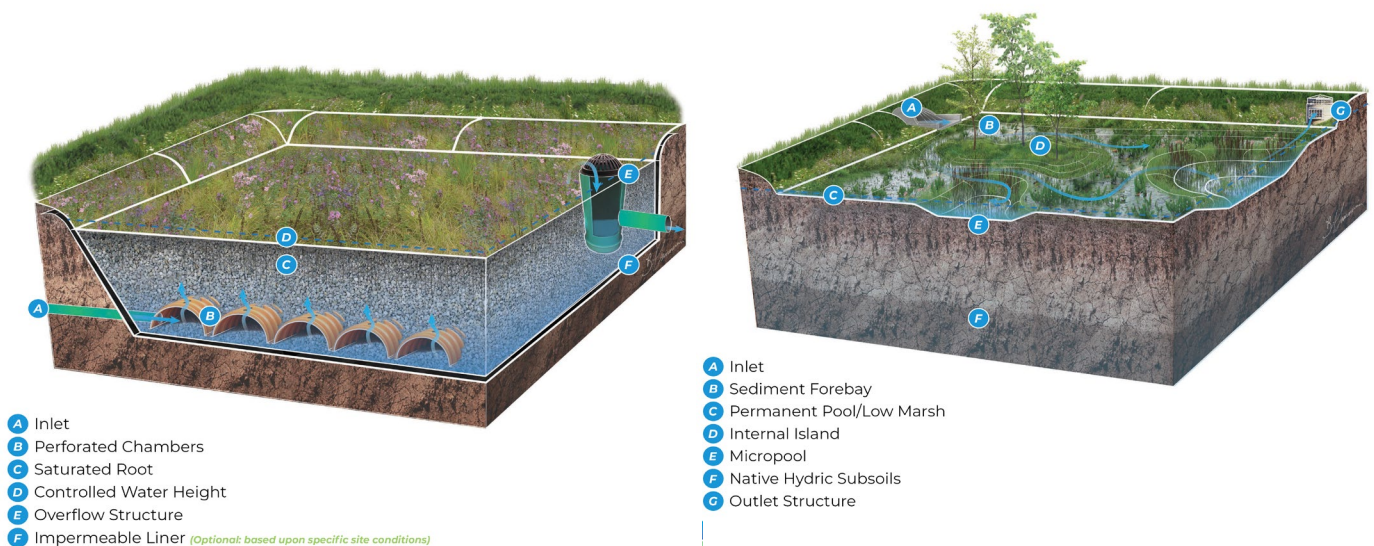

Example of gravel wetland with impermeable liner (left) and constructed shallow marsh design using high groundwater; no impermeable liner needed (right).

- The bed of a constructed wetland should be graded to create maximum internal flow path and microtopography. Microtopography (complex contours along the bottom of the constructed wetland, providing greater depth variation) is encouraged to enhance habitat diversity.

### Constructed Wetland Setbacks

- A constructed wetland setback shall be provided that extends 25 feet outward from the maximum design water surface elevation of the constructed wetland.
- For Shallow Constructed Marshes designed to meet water quantity requirements (storm events > 1yr) with embankments, woody vegetation shall not be planted or allowed to grow on a dam, or within 15 feet of a dam or toe of the embankment, or within 25 feet of a principal spillway outlet.
- An additional setback (greater than 25 feet outward from the maximum design water surface elevation of the constructed wetland) may be provided to permanent structures.
- Existing trees should be preserved in the setback area during construction. It is desirable to locate forest conservation areas adjacent to a constructed wetland. To help encourage reforestation, the setback can be planted with trees, shrubs and native ground covers.
- Annual mowing of the constructed wetland setback is only required along maintenance rights-of-way and the embankment. The remaining setback can be managed as a meadow (mowing every other year) or forest.

### Outlet Control Structure (Principal Spillway)

- The outlet control structure shall be located for maintenance access, safety and aesthetics.
- For on-line practices, the outlet control structure shall be sized and designed for  $G_{pv}$  and  $Q_{p,r}$ , as required based on hydraulic and hydrologic modeling. The top of the structure should be at least 1 ft below the emergency spillway crest.
- All pipe connections should be watertight.
- Access to the outlet control structure for large storage wetlands should be provided by lockable manhole covers, and manhole steps within easy

reach of valves and other controls. The principal spillway opening should be "fenced" with pipe or rebar at 8-inch intervals (for safety purposes).

- **Anti-vortex device and trash rack:** For large storage wetlands, an anti-vortex device and trash rack shall be securely installed on top of the structure.
- **Base:** The outlet structure base shall be attached with a watertight connection and have sufficient weight to prevent flotation of the riser.
- **Outlet Pipe:** For on-line constructed wetlands, the outlet pipe should be designed by an engineer with a capacity for the peak flow from the 25-year, 24-hour design storm. All pipe material shall be of good quality with no holes, with watertight connections. Outlet protection should be used at the downstream end to prevent erosion. If discharges are at the property line, drainage easements will be obtained in accordance with DPNR requirements. Do not use pervious materials such as sand or gravel as backfill around pipe.
- **Anti-seep Collar:** For large storage wetlands, an anti-seep collar with watertight connections shall be used and placed 25 feet from the riser. Do not use pervious materials such as sand or gravel as backfill around anti-seep collar.

### Emergency Spillway

For on-line constructed wetlands, an emergency spillway is required and should be designed by an engineer to safely convey the peak flows from the 100-year, 24-hour design storm. Typical spillways are trapezoidal, with a minimum of 8-ft bottom width and 2:1 side slopes. Spillway design capacity should be analyzed as a broad crested weir. The spillway should be stabilized by vegetation or rock based on anticipated velocities. There should be a minimum of 1 ft of freeboard between the spillway and top of the embankment.

### Embankments

For large storage constructed wetlands, Embankment height should not exceed 10 feet and should have a minimum 8 foot wide top and side slopes of 2:1 or flatter. Embankments greater than 6 ft should be designed by a professional engineer with geotechnical expertise and meet all necessary dam safety requirements. Embankment material shall be clean soil free of roots, woody vegetation, large rocks or other

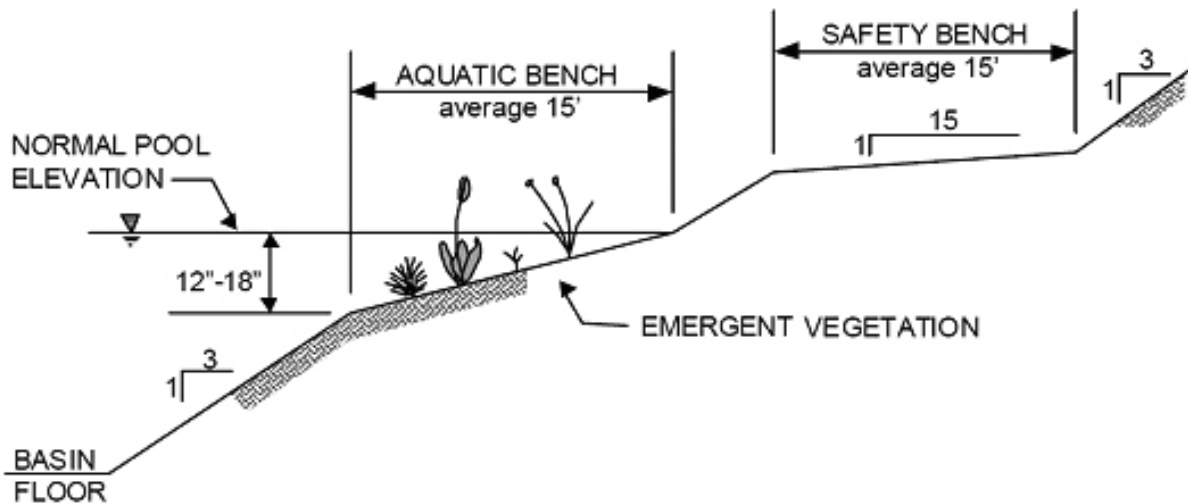

Figure 5.17 Typical Shallow Constructed Marsh Geometry Criteria (ARC, 2001)

objectionable material. Do not use pervious materials such as sand and gravel. Place material in 8-in layers and continuously compact to a minimum 95% of the Standard Proctor Maximum Density, ASTM Procedure D698.

**Cutoff Trench:** A cutoff trench should be designed along the centerline of the embankment that is a minimum of 2 ft deep with a 4-ft wide base and minimum 1:1 side slopes. The cutoff trench should be compacted and extend up both abutments to the riser crest elevation.

### Constructed Wetland Drain

Except where local slopes (e.g., coastal areas) prohibit this design and in smaller applications without an outlet structure, each large storage constructed wetland should have a drain pipe that can completely or partially drain the practice. The drain pipe shall have an elbow or protected intake within the constructed wetland to prevent sediment deposition, and a diameter capable of draining the permanent pool within 24 hours. Access to the drain pipe shall be secured by a lockable structure to prevent vandalism and/or accidental draining of the pond, which could pose a safety hazard due to high drainage velocities.

### Safety Features

- Proposed graded side slopes to the constructed wetland shall not exceed 3:1 (h:v), and shall terminate on the safety bench.

- The principal spillway opening shall not permit access by small children, and endwalls above pipe outfalls greater than 48 inches in diameter shall be fenced to prevent a hazard.
- Both the safety and the aquatic bench may be landscaped to prevent access to permanent pool.
- Warning signs prohibiting swimming may be posted.
- Fencing is generally not encouraged but may be required by some owners and/or agencies. A preferred method is to manage the contours of the constructed wetland to eliminate dropoffs or other safety hazards.

### Vegetation

#### Shallow Constructed Marsh Benches

The perimeter of all deep pool areas (four feet or greater in depth) shall be surrounded by two benches as follows:

- Except when side slopes are 4:1 (h:v) or flatter, provide a safety bench that generally extends 15 ft outward (a 10ft minimum bench is allowable on sites with extreme space limitations at the discretion of the approving agency) from the normal water edge to the toe of the constructed wetland side slope. The maximum slope of the safety bench shall be 6%; and
- Incorporate an aquatic bench that generally extends up to 15 feet inward from the normal edge of water, has an irregular configuration, and

a maximum depth of 18 inches below the normal pool water surface elevation.

### Planting Plan

- A planting plan for a constructed wetland and its setback shall be prepared to indicate how aquatic and terrestrial areas will be stabilized and established with vegetation. Minimum elements of a plan include: delineation of pondscaping zones, selection of corresponding plant species, plant locations, sequence for preparing constructed wetland bed (including soil amendments, if needed), and sources of plant material.
- Soils for constructed wetlands shall not be removed from natural wetlands.
- The best elevations for establishing emergent plants, either through transplantation or volunteer colonization, are within six inches (plus or minus) of the normal pool.
- The soils of a constructed wetland setback are often severely compacted during the construction process to ensure stability. The density of these compacted soils is so great that it effectively prevents root penetration, and therefore, may lead to premature mortality or loss of vigor. Consequently, it is advisable to excavate large and deep holes around the proposed planting sites and backfill these with uncompacted topsoil.
- A Gravel Constructed Wetland should be planted to achieve a rigorous root mat with grasses, forbs, and shrubs with obligate and facultative wet species.
- Planting holes should be the same depth as the root ball and two to three times wider than the diameter of the root ball. In addition, the root ball of container-grown stock should be gently loosened or scored along the outside layer or roots to stimulate new root development. This practice should enable the stock to develop unconfined root systems. Avoid species that require full shade or are prone to wind damage. Extra mulching around the base of a tree or shrub is strongly recommended as a means of conserving moisture and suppressing weeds (*Save the Bay, 1999*).
- Structures such as fascines, coconut rolls, or carefully designed stone weirs can be used to

create shallow cells in high-energy flow areas of the constructed wetland.

### Maintenance

- General inspections shall be conducted on an annual basis and after storm events greater than or equal to the 1-year event.
- The principal spillway shall be equipped with a removable trash rack, and generally accessible from dry land.
- A maintenance and operation plan must specify that sediment removal in the forebay shall occur every 5 years or after 50% of total forebay capacity has been lost, whichever occurs first.
- An operation and maintenance plan shall specify that if a minimum vegetative coverage of 50% is not achieved in the planted areas after the second growing season, a reinforcement planting is required.
- Sediment and organic build-up shall be removed from a Gravel Constructed Wetland every 2 years, as needed.

Table 5.13 Plant species for shallow and gravel wetlands (USDA-SCS Caribbean Area, 1992 & 1993).

Species Acceptable for Shallow Constructed Wetlands
<p><u>Primary Species</u></p> <p><i>Scirpus californicus</i> (bulrush)</p> <p><i>Scirpus validus</i> (softstem bulrush)</p> <p><i>Typha</i> spp. (cattail)</p> <p><i>Panicum hemitomon</i> (maidencane)</p> <p><u>Secondary Species</u></p> <p><i>Dieffenbachia</i> spp.</p> <p><i>Cyperus</i> spp.</p> <p><i>Colocasia</i> spp. (malangas)</p> <p><i>Canna flacida</i> (canna lily)</p> <p><i>Colocasia esculenta</i> (elephant ear)</p>
Species Acceptable for Gravel Constructed Wetlands
<p><i>Phragmites communis</i> (common reed grass)</p> <p><i>Typha</i> spp. (cattail)</p> <p><i>Brachiaria mutica</i> (paragrass)</p> <p><i>Eriochloa polystachya</i> (caribgrass)</p> <p><i>Brachiaria arrecta</i> (taner grass)</p> <p><i>Echinochloa polystachya</i> (aleman grass)</p>

- In a Gravel Constructed Wetland, vertical cleanouts must be constructed that are connected to the distribution and collection subdrains at each end.
- Woody vegetation in wet swales shall be pruned where dead or dying branches are observed, and reinforcement plantings shall be planted if less than 50% of the original vegetation establishes after two years.
- Areas with a permanent pool should be inspected on an annual basis. The maintenance objectives for these practices include preserving the hydraulic and removal efficiency of the constructed wetland and maintaining the structural integrity.
- The slopes of the basin or constructed wetland should be inspected for erosion and gulying. Reinforce existing riprap if riprap is found to be deficient, erosion is present at the outfalls of any control structures, or the existing riprap has been compromised. Re-vegetate slopes as necessary for stabilization.
- All structural components, which include, but are not limited to, trash racks, access gates, valves, pipes, weir walls, orifice structures, and spillway structures, should be inspected and any deficiencies should be reported. This includes a visual inspection of all stormwater control structures for damage and/or accumulation of sediment.
- All dead or dying vegetation within the extents of the constructed wetland should be removed, as well as all herbaceous vegetation rootstock when

overcrowding is observed and any vegetation that has a negative impact on stormwater flowage through the facility. Any invasive plants encroaching upon the perimeter of the facility should be pruned or removed if it is prohibiting access, compromising sight visibility and/or original design vegetation.

#### Maintenance Access

- A maintenance right of way or easement shall extend to a constructed wetland from a public or private road.
- Maintenance access should be at least 10 feet wide, have a maximum slope of no more than 15%, and be appropriately stabilized to withstand maintenance equipment and vehicles.
- The maintenance access should extend to the forebay(s), safety bench, emergency spillway, outlet control structure, and outlet and be designed to allow vehicles to turn around.
- The grass around the perimeter of the constructed wetland should be mowed as needed to maintain vehicle access.

## Water Quality SCM Troubleshooting

There are always opportunities for something to go wrong, whether at the design, review, installation, or maintenance stage. **Table 5.14** summarizes some of the common problems that others have had when implementing water quality SCMs and ideas on how to avoid/solve them.

Table 5.14 Tips to Avoiding Common Pitfalls for Water Quality SCMs

What goes wrong	How to avoid/solve it		
	Design and Review Tips	Installation Tips	Maintenance Tips
<b>1. Inlets become clogged and runoff bypasses SCM.</b>	Nothing is more frustrating than spending time and money building SCM that may never get water! Design inlets with a greater elevation drop to prevent sediment from building up there and changing flow paths, particularly if you expect a lot of sediment from contributing area.	Ensure that the specified drop at the inlet is actually constructed. If a sufficient drop is not shown on the plan, consult the designer about a potential modification.	Be sure that the inlet area is inspected and maintained on a regular basis. Remove sediment blockages before they cause flooding. Once vegetation grows in the sediment, it is harder to remove.
<b>2. Overplanting the SCM</b>	Do not design a planting plan that completely fills the SCM the day it is constructed - Design for full coverage in 2-3 years, but seed areas of exposed soil that may become erosion problems. AVOID planting invasive species that could quickly take over.	Be sure that the plants are spaced according to the plan. Fast-growing species should be spaced farther apart than those that do not tend to spread quickly.	Don't underestimate the power of plants in the tropical climate. Plants should be trimmed/cut back when the design capacity of the SCM is reduced and/or plants clog and block the inlets and outlets, causing flooding.

What goes wrong	How to avoid/solve it		
	Design and Review Tips	Installation Tips	Maintenance Tips
<b>3. Lack of ESC controls for SCMs</b>	Be sure to specify appropriate ESC controls to protect the SCM during construction. Use erosion control matting and seeding on steep slopes, and a perimeter control such as silt fence or compost socks around the edge of the SCM.	Do not allow runoff to flow into the SCM before upgradient areas are stabilized with vegetation. Remove any sediment buildup during construction.	If a filter SCM constantly holds water several days after a rain event, the clogged surface layer must be removed and restored to design dimensions.
<b>4. No signage</b>	If people don't know what the SCM is, they might be more prone to damage them, and it is a lost education opportunity. Identify location for signage on the design plans in the most visible location for public outreach.	Ensure the sign gets installed securely as designed.	Spread the word – the more people see, the more there will be!
<b>5. Learning from O&amp;M and making adjustments.</b>	Design with maintenance in mind to start with.	Install plants in the locations identified on landscaping plans – they are usually placed based on expected wetness or dryness.	Make note of which plants do well, die off quickly, and spread aggressively, gobbling up other desirable plants. For dead plants, replant first time per plan – if the same species die again, then it was ill-suited for that location. Prune back or remove overly aggressive plants.
<b>Disregarding existing land use patterns</b>	Be aware of how the locals use the land around the proposed SCM, and take that into account with design. Adjust location to avoid heavy foot traffic or recreational areas such as ball fields.	Be sensitive to surrounding land use during construction – schedule activity to avoid conflicts with neighbors and schools. Educate on-lookers about SCM.	If people are consistently walking through the SCM, consider fencing and/or more signage. If trash constantly builds-up, consider a wind block.
<b>6. People eat contaminated foods that have been growing in your filter</b>	Plant selection is important. Avoid using edible plants, particularly if drainage area is a parking lot or other pollution hotspot for oils and other toxins.	Follow the landscape plan, and don't substitute plants without confirming with designer.	If you see people eating plants from your SCM ...remove species and replace with non-edible alternative
<b>7. No pretreatment</b>	For SCMs accepting road or other sediment-laden runoff, include a pretreatment measure sized for ~10% of the WQv.	Install all pretreatment practices as specified on the plans.	Remove sediment and other debris from the pretreatment measure when it is 50% full.
<b>8. Using mulch that contains weed seed or pests</b>	Minimize mulch for the SCM. Specify the type of mulch for the project and that it must be weed and pest free. List acceptable vendors if possible.	Inspect mulch before it is placed into the SCM, and send it back if pests or seeds are observed.	When replenishing mulch, be sure to follow original spec. Pests and invasives will harm not only your SCM, but the surrounding lands as well.



## 5.4 PRETREATMENT PRACTICES

There are several stormwater management practices that do not meet the runoff reduction or water quality performance

standards and therefore cannot be used as a stand-alone practice at a site but may be useful to provide pretreatment. Pretreatment SCMs are designed to improve water quality and enhance the effective

design life of practices by consolidating the maintenance to a specific location, but do not meet the runoff reduction and/or pollutant removal targets on their own. Pretreatment practices must be combined with an acceptable SCM from **Section 5.2 or 5.3** to meet the runoff reduction and/or water quality criteria. The figures and photographs included in this section are schematic graphics only. Design plans should be consistent with the schematic figures when using the method or practice described, but must be completely detailed by the designer for site-specific conditions and construction purposes.

Table 5.15 Summary of pretreatment SCMs and their typical relative benefits.

Benefits	Grass Channels	Sediment Forebays	Deep Sump Catch Basins	Proprietary Devices
Easy to Install	●	●		
Inexpensive	●	●		
Non-erosive			●	●
Good for Hotspots				●
Easy to Inspect	●	●		
Low Maintenance	●	●		
Provides Other Conveyance Benefits	●		●	●

## GRASS CHANNELS

A *grass channel* is a shallow, vegetated, man-made channel designed to pretreat a target volume of stormwater runoff prior to a runoff reduction or water quality SCM. The grass in the swale prevents erosion, filters sediment, and provides some nutrient uptake. The underlying soil can also provide some filtering and infiltration, absorb water, and decrease stormwater volumes. *Grass channels* can also be used to convey stormwater runoff from larger storm events.

### Feasibility

- Grass channels can be applied in most development situations as pretreatment for SCMs that are set back from the impervious cover they are treating.
- Hotspot runoff should not be directed toward grass channels (particularly for pervious soils and shallow groundwater) unless they are lined to prevent infiltration.



A pretreatment grass channel leading from parking lot to bioretention.

- Grass channels can be used for both pretreatment and conveyance to a SCM, an alternative to curb and gutter drainage systems.
- Individual grass channels should be used to pretreat small drainage areas (less than 1 acre typically).

## Minimum Plan Requirements

Details of grass channels shall be shown on the plan and contain the following items:

- Location(s) on site
- Flow calculations
- Grass species
- Detail showing maximum slope, checkdams if necessary, and anticipated depths for design storms
- Maintenance requirements

## Conveyance

Typical designs allow the runoff from the 1-year storm to flow through the grass channel without causing erosion. On-line grass channels should also have the capacity to pass larger storms (25-year storm) safely or should be designed for an off-line practice with a diversion method or structure to bypass runoff from storms larger than the target volume.

## Design

- Sizing of the grass channel length is based on flow rate from the water quality storm and should be designed to ensure an average residence time of ten (10) minutes to flow from the inlet to the outlet.
- Grass channels should be used on sites with fairly flat slopes (< 5%). Swale side slopes should be no greater than 3:1 (horizontal:vertical).
- Check dams can be installed in grass channels to better slow runoff and provide additional sediment trapping opportunities – see **Chapter 4** for checkdam design options.
- Channels should generally have a trapezoidal or parabolic cross section with relatively mild side slopes (generally, flatter than 3:1). Designing the channel with mild side slopes also maximizes the wetted perimeter. The wetted perimeter is the length along the edge of the channel cross section where runoff flowing through the channel is in contact with the vegetated sides and bottom of the channel. Increasing the wetted perimeter slows runoff velocities and provides more contact with vegetation to encourage filtering and infiltration. Another advantage of mild side slopes is that any runoff entering the grass channel from the side receives additional pretreatment along the side slope.

- The bottom of the channel should be between two and eight feet wide. The minimum width ensures a minimum filtering surface for pretreatment, and the maximum width prevents braiding, the formation of small channels within the channel bottom.
- Channels should have at least 18" separation from groundwater.
- A small forebay can be used at upstream end of the channel to trap incoming sediments from a contributing drainage area with high expected sediment load. A stone diaphragm (a small trench filled with gravel) can also be used to pretreat runoff that enters the sides of the channel.

## Vegetation

A dense cover of hardy, low-growing, erosion-resistant grass or groundcover must be established (such as bermuda, bahia, hurricane or zoysia grass).

## Maintenance

The maintenance objective for this practice includes preserving or retaining the hydraulic efficiency of the channel and maintaining a dense, healthy grass cover. The following activities should be performed on an annual basis or more frequently as needed:

- Sediment removal—when sediment accumulates to a depth of approximately ¼ of the original design depth, it should be removed, and the channel should be reconfigured to its original dimensions.
- Mowing and litter and debris removal—the grass in the channel should be mowed at least 2 times during the wet season and as needed during the dry season but never shorter than 4".
- Stabilization of eroded side slopes and bottom.
- Dethatching swale bottom and removal of thatching; and/or
- Discing or aeration of channel bottom.
- If the surface of the grass channel becomes clogged to the point that standing water is observed on the surface 48 hours after precipitation events, the bottom should be rototilled or cultivated to break up any hard-packed sediment, and then reseeded.
- Trash and debris should be removed and properly disposed.



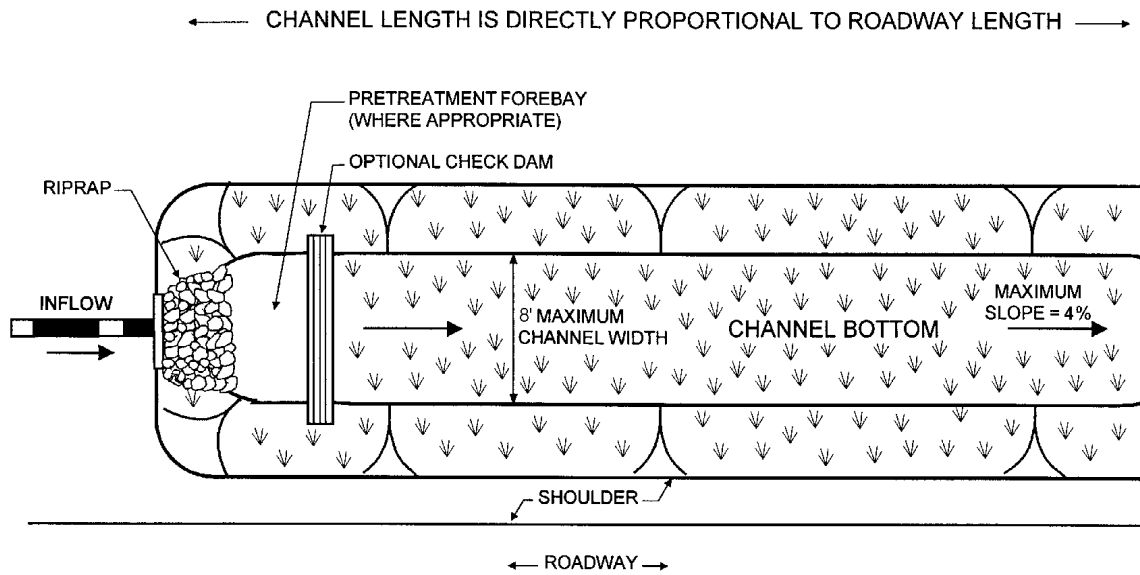

**PLAN VIEW**

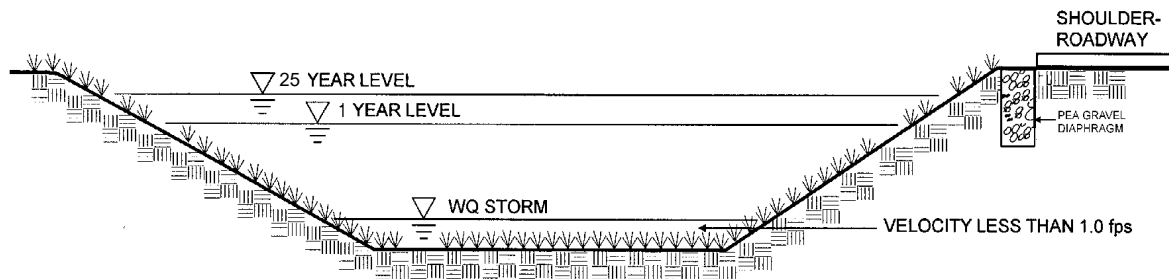

**SECTION**

Figure 5.18 Example Grass Channel (from RIDEM and CRMC, 2015 – Adapted from MDE, 2000)

## SEDIMENT FOREBAY

A *sediment forebay* can be used as a pretreatment device to minimize maintenance needs for stormwater SCMs. The purpose of the forebay is to provide pretreatment by settling out sediment particles. This will enhance treatment performance, reduce maintenance, and increase the longevity of the downstream stormwater facility. A *forebay* is a separate cell within the facility formed by a barrier such as a rock or concrete weir, or gabion baskets. The benefits of using a forebay for pretreatment include easy access for maintenance and a visual reminder when maintenance is required – underground pretreatment practices are often “out of sight, out of mind” and often don’t receive the maintenance they need.

### Minimum Plan Requirements

The following items must be shown on the design plans and/or included in the technical specifications:

- Location of all proposed sediment forebays on the site plan
- Details showing materials and dimensions of sediment forebay inlet, bottom, weir/checkdam, and other key components
- Installation methods and sequencing
- Specifications for pipe and tank materials

### Design

The minimum required surface area of the sediment forebay should be determined using the following equation that is based on Camp-Hazen.

$$A_s = -\frac{Q}{W} \ln(1 - E)$$

where:

$A_s$  = minimum sedimentation surface area (ft<sup>2</sup>)

$Q$  = discharge from drainage area (ft<sup>3</sup>/s) = %WQ<sub>v</sub><sup>1</sup>/86,400  
sec

$W$  = 0.0004 ft/s particle settling velocity recommended  
for silt

$E$  = sediment removal efficiency (assume 0.9 or 90%)

$$A_s = 5,750 * Q$$

<sup>1</sup>The percent of the water quality volume used for the sediment forebay design should be at least 10%.

- The forebay shall have a minimum length to width ratio of 1:1 and a preferred minimum length to width ratio of 2:1 or greater.
- Designers shall calculate scour potential at the inlet and provide a stabilized surface and sizing



*Concrete weir created from old curbing used to create sediment forebay for this bioretention (top); paved concrete flume used as a forebay for a pond in St. John (middle).*

calculations to effectively dissipate erosive velocities. Often, riprap has been used in forebays, but sediment is extremely difficult to remove from riprap so designers should consider other stabilization methods such as pavers.

- The forebay shall be sized to contain at least 10% of the WQ<sub>v</sub> and be of an adequate depth to prevent resuspension of collected sediments during the design storm. The goal of the forebay is to at least remove particles consistent with the size of medium sand.
- The outlet from the forebay should be designed in a manner to prevent erosion of the embankment and primary pool. This outlet can be configured in a number of ways, such as a culvert, weir, or spillway channel. The outlet should be designed to convey the same design flow proposed to enter the structure. The outlet invert should be elevated in a manner such that 10% of the WQ<sub>v</sub> as well as the required sediment volume can be stored

below it. The outlet should be stabilized to prevent erosion in the SCM.

- The sediment forebay may be designed with a permanent pool.

### Maintenance

- Direct access for appropriate maintenance equipment needs to be provided to the forebay and may include a ramp to the bottom of the embankment if equipment cannot reach all points within the forebay from the top of the embankment.
- Forebays should be cleaned when they are 50% full of sediment and debris.
- Side slopes should be inspected for gullying/erosion and stabilized as necessary.
- The overflow weir or checkdam should be inspected for end run. The weir/checkdam should be fully keyed into the embankment to prevent scour around the ends.
- The forebay can be lined with pavers or a concrete pad to allow easy removal of sediment and to minimize the possibility of excavating subsurface soils or undercutting embankments during routine



*Examples of hardened sediment forebays (with permeable pavers) for easy maintenance that will also drain down after storms.*

maintenance. Riprap should be avoided as a liner due to the difficulty in removing sediment from the rocks.

- A fixed vertical sediment depth marker should be installed in the forebay to measure sediment deposition.

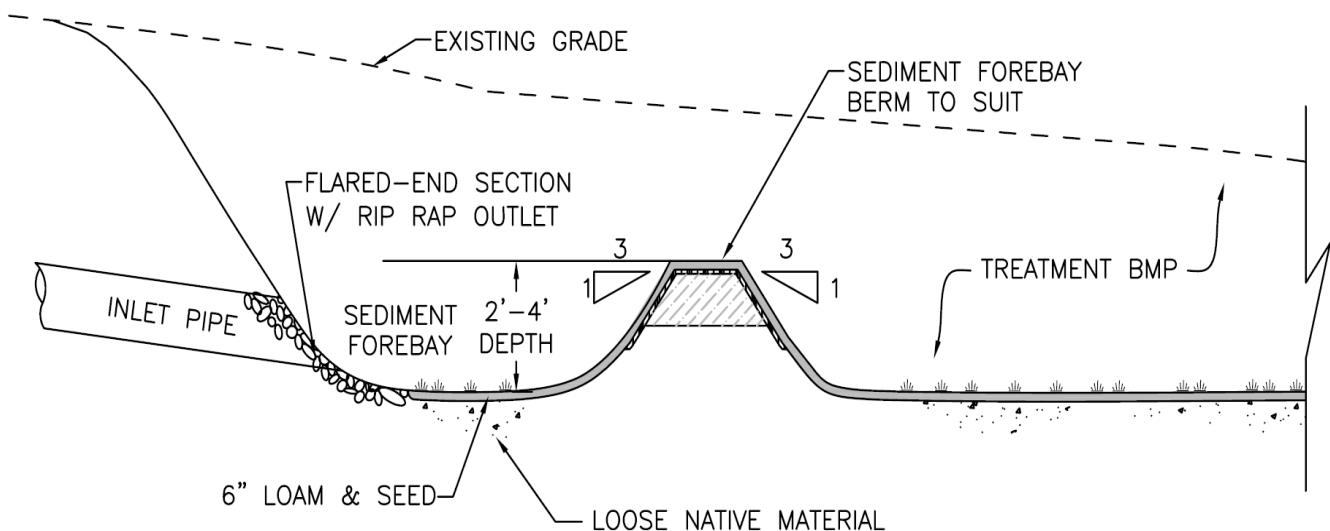

*Figure 5.19 Example Sediment Forebay profile*

## DEEP SUMP CATCH BASIN

*Deep sump catch basins* are modified inlet structures that can be installed in a piped stormwater conveyance system to remove trash, debris, and coarse sediment. They can also serve as temporary spill containment devices for floatables such as oils and greases but shall not be used in place of an oil grit separator for hotspots that have the potential to generate runoff with high concentrations of oil and grease.

### Feasibility

- The deep sump catch basin must be designed in a catch basin-to-manhole configuration (NOT in a catch basin-to-catch basin configuration) to be used as pretreatment for other SCMs. Catch basin-to-catch basin or inlet-to-inlet configurations are acceptable at a site, but they cannot be counted as a pretreatment practice, i.e., an additional pretreatment practice will be required at the outfall.
- The contributing drainage area to each deep sump catch basin shall not exceed 0.5 acres of impervious cover.
- Potential site constraints include the presence of utilities, bedrock, and high groundwater elevations.
- Inlet capacity sizing requirements on steep slopes.

### Minimum Plan Requirements

The following items must be shown on the design plans and/or included in the technical specifications:

- Location of all deep sump catch basins on the site plan
- Details showing catch basin materials and dimensions, including sump depth
- Installation methods and sequencing
- Specifications for all materials

### Design

- The deep sump shall be a minimum 4-ft deep below the lowest pipe invert or four times the diameter of the outlet pipe, whichever value is greater.
- The inlet grate shall be sized based on the contributing drainage area to ensure that the flow rate does not exceed the capacity of the grate.

- Inlet grates designed with curb cuts must reach the back of the curb cut to prevent flow bypass.
- Hooded outlets shall be used in high litter land uses. Care shall be taken to avoid damaging and displacing hoods during cleaning.
- The inlet grate should have openings not more than 4 square inches to prevent large debris from collecting in the sump.

### Maintenance

- Inspections shall be performed a minimum of 2 times a year (once every 6 months). Units shall be cleaned annually and whenever the depth of sediment is greater than or equal to half the sump depth.
- The inlet grate shall not be welded to the frame so that the sump can be easily inspected and maintained.
- Sufficient maintenance access shall be considered when designing the geometry of deep sump catch basins.

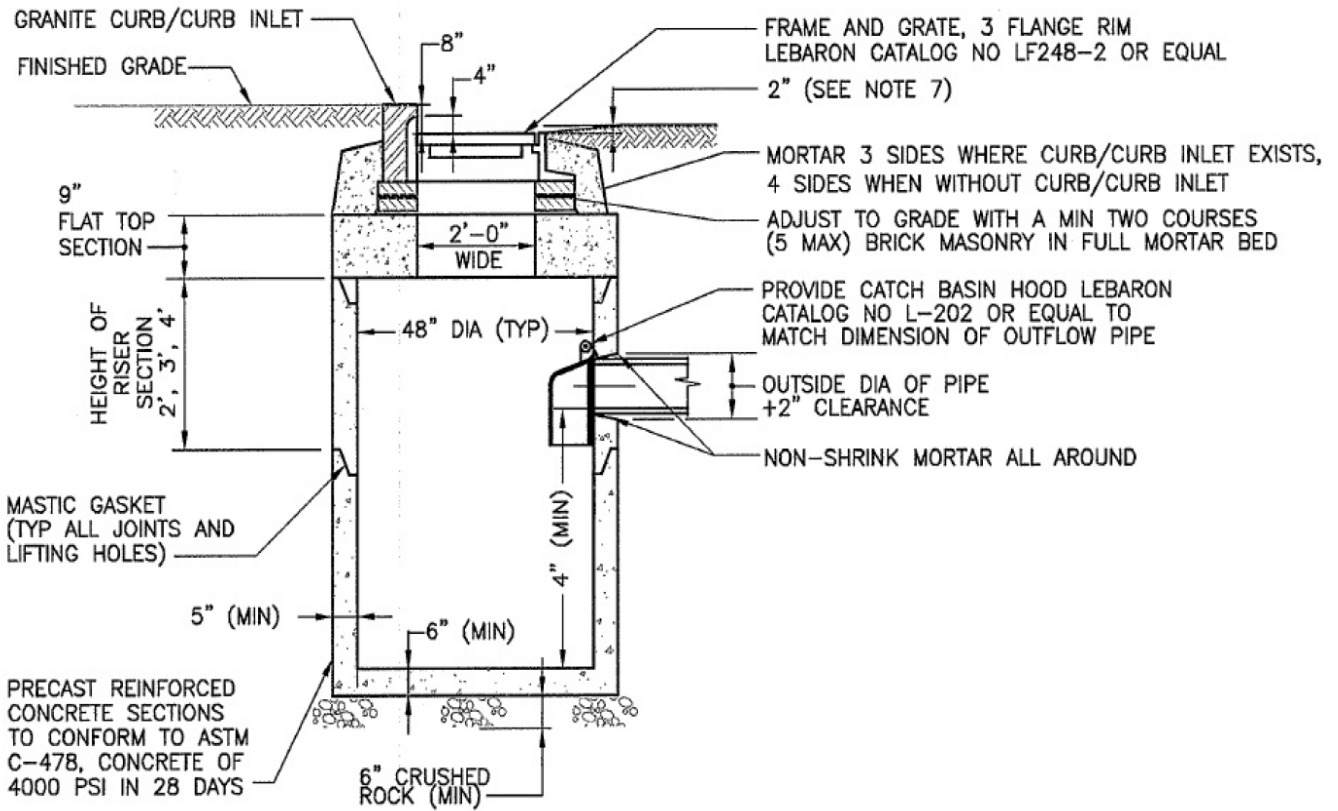

Figure 5.20 Deep Sump Catch Basin (MADEP, 2008)

## PROPRIETARY DEVICES

Many *proprietary devices* have been developed over the years in an attempt to provide cost-effective stormwater treatment, particularly for retrofit situations, including oil/grit separators, hydrodynamic devices, and a range of media filtration devices, among others.

Some studies have shown that many of these proprietary devices are not capable of achieving the required water quality performance required or that there is insufficient documentation to add these practices to the list of acceptable water quality SCMs. However, they may provide pretreatment if an independent third-party monitoring group verifies that it removes a minimum of 25% TSS for the flow rate associated with the  $WQ_v$ . Oil/grit separators are particularly useful pretreatment practices for runoff from hotspots that are expected to have high pollutant loads of oils and grease.

While proprietary devices must be designed per the manufacturer's recommendations, the following general design criteria apply.

### Feasibility

- To qualify as an acceptable pretreatment device, proprietary devices shall remove a minimum of 25% TSS, as verified by an independent third-party monitoring group. In certain retrofit cases and other cases where higher pretreatment standards may be appropriate, higher removal efficiency for TSS may be required in order to achieve stormwater treatment goals for the project.
- Proprietary devices shall be designed per the manufacturer's recommendations.
- Proprietary devices must be designed as off-line systems or have an internal bypass to avoid large flows and resuspension of pollutants in order to be used as pretreatment for other SCMs.
- The contributing drainage area to each proprietary device should generally not exceed 1 acre of impervious cover.
- Potential site constraints include the presence of utilities, bedrock, and high water tables.



*Use of underground proprietary device prior to bioretention on the Big Island of Hawaii.*

- Proprietary devices such as oil/grit separators should be used at hotspots that are expected to have high pollutant loads of oils and grease prior to a runoff reduction or water treatment SCM.

### Minimum Plan Requirements

The following must be shown on the design plans and/or included in the technical specifications:

- Location of all proprietary pretreatment practices on the site plan
- Details showing materials and dimensions of key components
- Installation methods and sequencing

### Design

- Flow-through proprietary devices shall be designed to treat runoff from the entire  $WQ_v$ . For these devices, a minimum detention time of 60 seconds is required for the  $WQ_v$ .
- A storage proprietary device shall be sized based on the required pretreatment volume (10%  $WQ_v$ ) or a designer must provide documentation that it is sized appropriately for a verified minimum removal of 25% TSS.
- For proprietary devices such as oil/grit separators, all baffles shall be tightly sealed at sidewalls and at the roof to prevent the escape of oil.
- Roof drains can bypass proprietary devices as most roof runoff is considered cleaner than runoff from roads and parking lots.

## Maintenance

- Proprietary devices shall be maintained in accordance with manufacturers' guidelines.
- Proprietary devices shall be located such that they are accessible at times for maintenance and/or emergency removal of oil or chemical spills.
- Inspections shall be performed a minimum of 2 times a year. Devices shall be cleaned when pollutant removal capacity is reduced by 50% or more, or where 50% or more of the pollutant storage capacity is filled or displaced. Hazardous debris removed shall be disposed of in accordance with USVI and federal regulations by a properly licensed contractor.

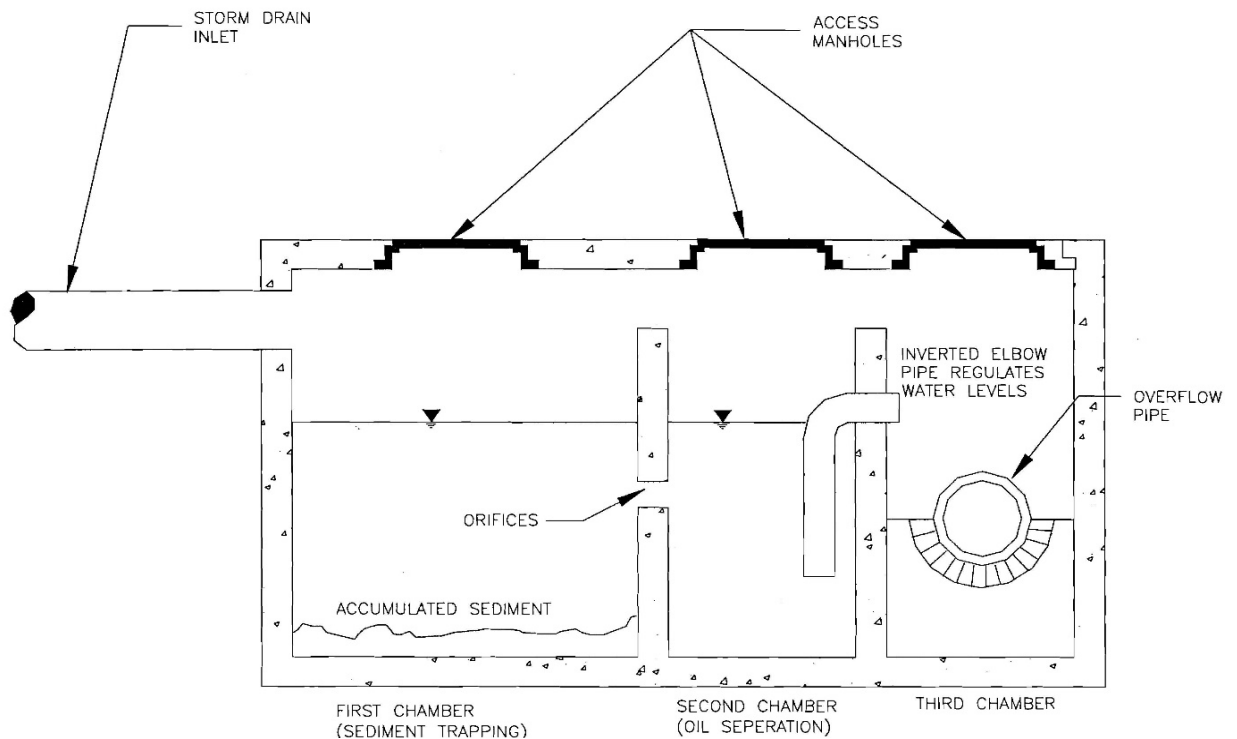

Figure 5.21 Oil and Grit Separator (MassHighway, 2004)



## 5.5 LARGE STORAGE PRACTICES

In addition to the pretreatment practices described in **Section 5.4**, there are also SCMs that do not meet the runoff reduction or water quality standards (SW 2 and 3), but may be used to meet stormwater quantity control criteria (i.e., storage and extended detention for  $G_{p_v}$  and  $Q_p$ ) for standards SW-4 and 5 if required. The “storage”

practices included in this section are explicitly designed to provide stormwater detention; these practices can be used to meet gut and flood protection, but must be combined with other SCMs for meeting water quality and recharge criteria. The figures and photographs included in this section are schematic graphics only. Design plans should be consistent with the schematic figures when using the method or practice described, but must be completely detailed by the designer for site-specific conditions and construction purposes.

Table 5.16 Summary of large storage SCMs and their typical relative benefits.

Benefits	Wet Extended Detention Basin	Dry Extended Detention Basin	Underground Storage
Easy to Install	●	●	
Inexpensive	●	●	
Space efficient			●
Aesthetics	●		●
Less Public Safety Concerns			●
Low Maintenance	●	●	

## STORMWATER BASINS

All stormwater basin design variations can be used to provide gut protection volume ( $G_{p_v}$ ) as well as overbank flood attenuation ( $Q_p$ ) but are not an acceptable option for meeting water quality treatment goals. Two design variants include: Dry Extended Detention Basins (**Figure 5.22**) and Wet Extended Detention Basins (**Figure 5.23**). Wet basins may be located in the groundwater table; dry basins do not need a permanent pool and may be designed such that the groundwater table is at or below the bottom of the basin.

### Feasibility

- Stormwater basins shall not be located within jurisdictional waters, including wetlands.
- Wet Extended Detention Basins shall have a minimum contributing drainage area of 25 acres, unless groundwater is intercepted.
- Wet Extended Detention Basins receiving runoff from hotspots must be lined and shall not intercept groundwater.
- Wet Extended Detention Basins that do intercept groundwater (allowed as long as not receiving



Example of a large basin with outlet structure at St. Croix landfill (top) and a smaller basin with inflow and outflow pipe at a resort on St. Thomas (bottom).



runoff from hotspots) shall not include the volume of the permanent pool in storage calculations.

- Assess the hazard classification<sup>5</sup> of the proposed structure and consider alternative placement and/or design refinements to reduce or eliminate the potential for designation as a significant or high hazard dam.
- The permanent pool of wet basins should have a minimum 4-foot depth and hold a minimum 0.5"/impervious acre draining to the basin for aesthetics and ease of maintenance.

## Minimum Plan Requirements

The following items must be shown on the design plans and/or included in the technical specifications:

- Location of all basins on the plans
- Grading plan showing basin contours and components
- Details showing inlet protection, outlet structure features and elevations, outlet protection, information on proposed berms/dams, and other key components
- Installation methods and sequencing
- Specifications for materials

## Conveyance

### Inlet Protection

- A forebay may be provided at each inlet, but pretreatment/treatment must be provided at upstream SCMs.
- Inlet areas should be stabilized to ensure that non-erosive conditions exist for at least the 1-year frequency storm event.
- Partially submerged (i.e., 1/2 full) inlet pipes are acceptable and can limit erosive conditions.

### Adequate Outfall Protection

- The channel immediately below a basin outfall shall be modified to prevent erosion and conform to natural dimensions in the shortest possible

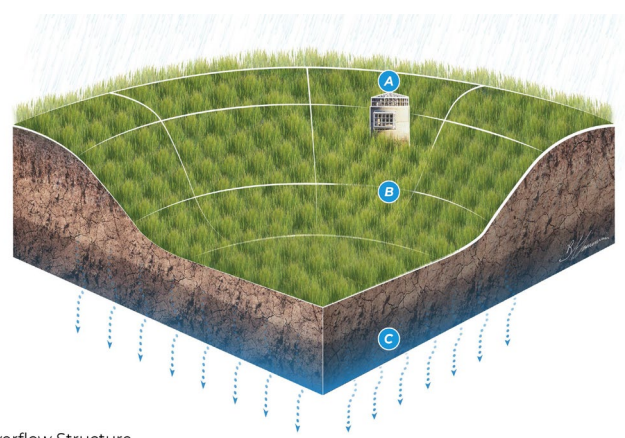

- A Overflow Structure
- B Storage Basin
- C Native Subsoil

### Key components of an extended detention basin

distance, typically by use of appropriately sized riprap apron.

- A stilling basin or outlet protection shall be used to reduce flow velocities from the principal spillway to non-erosive velocities (3.5 to 5.0 fps).
- Outfalls, where needed, shall be constructed such that they do not increase erosion or have undue influence on the downstream geomorphology of any gut by discharging at or near bottom of the slope or into an energy dissipating step-pool arrangement.
- All basins shall have an emergency outlet to accommodate the storm flow in excess of the 100-year storm event maintaining at least one foot of freeboard between the peak storage elevation and the top of the embankment crest, and to safely convey the 100-year storm without overtopping the embankment.
- If a basin discharges to a gut, care should be taken to minimize tree clearing along the downstream channel, and to reestablish a forested riparian zone in the shortest possible distance.

### Basin Liners

When a wet basin is located in medium to coarse sands or more permeable parent material, an

<sup>5</sup> "Hazard classification" is a rating for a dam that relates to the probable consequences of failure or misoperation based on an assessment of loss of human life and damages to properties or structures located downstream of an impoundment. A proposal to construct an impoundment

having a dam 6 feet in height or more, or a capacity of 15 acre-feet or more, or that is a significant or high hazard dam may subject the applicant to additional requirements in accordance with the Federal Dam Safety Program.

impermeable liner may be needed to sustain a permanent pool of water.

### Treatment

- Stormwater basins shall not be used for meeting the runoff reduction or water quality treatment standards.
- It is generally desirable to provide the upstream runoff reduction/water quality treatment off-line when topography, head, and space permit.
- Additional treatment can be provided within these practices when multiple pathways are provided by using multiple cells, longer flowpaths, high surface area to volume ratios, complex microtopography, and/or redundant treatment methods (combinations of pool, ED, and shallow water).

### Minimum Basin Geometry

To the greatest extent possible, should maximize flow path through the system, and design basins with irregular shapes and/or baffles.

### Basin Setbacks

- A basin setback from structures, roads, and parking lots shall be provided that extends 25 feet outward from the maximum water surface elevation of the basin.
- Woody vegetation shall not be planted or allowed to grow on a dam, or within 15 feet of a dam or toe of the embankment, or within 25 feet of a principal spillway outlet.
- An additional setback may be provided to permanent structures.
- Existing trees should be preserved in the setback area during construction. It is desirable to locate forest conservation areas adjacent to basins. To help encourage reforestation, the setback can be planted with trees, shrubs, and native groundcover.

### Non-clogging Low-flow Orifice

- When  $G_p$  control is required, a low-flow orifice shall be provided, with the design of the orifice sufficient to ensure that no clogging shall occur.



*Detention basin at a resort on the east end of St. Croix.*

- The low-flow orifice should be adequately protected from clogging by either an acceptable external trash rack (recommended minimum orifice of 3") or by internal orifice protection that may allow for smaller diameters (recommended minimum orifice of 1").
- The preferred method for practices with a permanent pool is a submerged reverse-slope pipe that extends downward from the outlet control structure to an inflow point one foot below the normal pool elevation (see **Figure 5.23** for schematic profile).
- Alternative methods are to employ a broad-crested rectangular, V-notch, or proportional weir, protected by a half-round pipe or "hood" that extends at least 12 inches below the normal pool.
- The use of horizontally extended perforated pipe protected by geotextile fabric and crushed stone is not recommended. Vertical pipes may be used as an alternative if a permanent pool is present.

### Outlet Control Structure (Principal Spillway)

- The outlet control structure shall be located within the embankment for maintenance access, safety and aesthetics.
- The outlet control structure shall be sized and designed for  $G_p$  and  $Q_p$ , as required based on hydraulic and hydrologic modeling. The top of the structure should be at least 1 ft below the emergency spillway crest.
- All pipe connections should be watertight.

- Access to the outlet control structure should be provided by lockable manhole covers, and manhole steps within easy reach of valves and other controls. The principal spillway opening should be "fenced" with pipe or rebar at 8-inch intervals (for safety purposes).
- **Anti-vortex device and trash rack:** An anti-vortex device and trash rack shall be securely installed on top of the structure.
- **Base:** The outlet structure base shall be attached with a watertight connection and have sufficient weight to prevent flotation of the riser. Typical bases consist of concrete or steel plates with dimensions at least twice the riser diameter.
- **Outlet Pipe:** The outlet pipe should be designed by an engineer with a capacity for the peak flow from the 25-year, 24-hour design storm. All pipe material shall be of good quality with no holes, with watertight connections. Outlet protection should be used at the downstream end to prevent erosion. If discharges are at the property line, drainage easements will be obtained in accordance with DPNR requirements. Do not use pervious materials such as sand or gravel as backfill around pipe.
- **Anti-seep Collar:** An anti-seep collar with watertight connections shall be used and placed 25 feet from the riser. Do not use pervious materials such as sand or gravel as backfill around anti-seep collar.

### Emergency Spillway

An emergency spillway is required and should be designed by an engineer to safely convey the peak flows from the 100-year, 24-hour design storm. Typical spillways are trapezoidal, with a minimum of 8-ft bottom width and 2:1 side slopes. Spillway design capacity should be analyzed as a broad crested weir. The spillway should be stabilized by vegetation or rock based on anticipated velocities. There should be a minimum of 1 ft of freeboard between the spillway and top of the embankment.

### Embankments

Embankment height should not exceed 10 feet and should have a minimum 8 foot wide top and side slopes of 2:1 or flatter. Embankments greater than 6 ft should be designed by a professional engineer with



*Outfall protection needed at this outlet onto an erodible beach.*

geotechnical expertise and meet all necessary dam safety requirements. Embankment material shall be clean soil free of roots, woody vegetation, large rocks or other objectionable material. Do not use pervious materials such as sand and gravel. Place material in 8-in layers and continuously compact to a minimum 95% of the Standard Proctor Maximum Density, ASTM Procedure D698.

**Cutoff Trench:** A cutoff trench should be designed along the centerline of the embankment that is a minimum of 2 ft deep with a 4-ft wide base and minimum 1:1 side slopes. The cutoff trench should be compacted and extend up both abutments to the riser crest elevation.

### Basin Drain

Except where local slopes prohibit this design, each wet basin shall have a drain pipe that can completely or partially drain the permanent pool. The drain pipe shall have an elbow or protected intake within the basin to prevent sediment deposition, and a diameter capable of draining the basin within 24 hours. Access to the drain pipe shall be secured by a lockable structure to prevent vandalism and/or accidental draining of the pond, which could pose a safety hazard due to high drainage velocities.

### Safety Features

- Side slopes to the basin shall not exceed 3:1 (h:v) and, for wet basins, shall terminate on a safety bench.
- The principal spillway opening shall not permit access by small children, and endwalls above pipe

outfalls greater than 48 inches in diameter shall be fenced to prevent a hazard.

- Both the safety bench and aquatic bench may be landscaped to prevent access to the pool.
- Warning signs prohibiting swimming may be posted.
- Basin fencing is often appropriate and may be required by the owner or by local ordinance in residential neighborhoods. However, a preferred method for public safety is to manage the contours of the basin to eliminate dropoffs or other safety hazards.

## Vegetation

### Basin Benches

For wet basins, the perimeter of all deep pool areas (four feet or greater in depth) shall be surrounded by a safety bench. Except when basin side slopes are 4:1 (h:v) or flatter, provide a safety bench that generally extends 15 feet outward (a 10' minimum bench is allowable on sites with extreme space limitations at the discretion of the approving agency) from the normal water edge to the toe of the basin side slope.

The maximum slope of the safety bench shall be 6%. Design should incorporate an aquatic bench that extends up to 15 feet inward from the normal edge of water, has an irregular configuration, and a maximum depth of 18 inches below the normal pool water surface elevation.

### Planting Plan

- A planting plan for a stormwater basin and its setback shall be prepared to indicate how the basin perimeter will be stabilized and established with vegetation.
- Wherever possible for wet basins, emergent plants should be encouraged in a basin design, either along the aquatic bench, the safety bench and side slopes or within shallow areas of the pool itself. The best elevations for establishing emergent plants, either through transplantation or volunteer colonization, are within six inches (plus or minus) of the normal pool.

- The soils of a basin setback are often severely compacted during the construction process to ensure stability. The density of these compacted soils is so great that it effectively prevents root penetration, and therefore, may lead to premature mortality or loss of vigor. Consequently, it is advisable to excavate large and deep holes around the proposed planting sites, and backfill these with uncompacted topsoil.
- Planting holes should be the same depth as the root ball and two to three times wider than the diameter of the root ball. In addition, the root ball of container-grown stock should be gently loosened or scored along the outside layer or roots to stimulate new root development. This practice should enable the stock to develop unconfined root systems. Avoid species that require full shade or are prone to wind damage. Mulching just around the base of a tree or shrub is strongly recommended as a means of conserving moisture and suppressing weeds (Save the Bay, 1999).

## Maintenance

- The principal spillway shall be equipped with a removable trash rack, and generally accessible from dry land.
- A maintenance right-of-way or easement shall extend to a basin from a public or private road.
- Sediment shall be removed from stormwater basins when the sediment volume exceeds 10% of the total basin volume and should be disposed of according to the operation and maintenance plan.
- Mowing of the basin setback is only required along maintenance rights-of-way and the embankment. The remaining setback can be managed as meadow or forest.
- Maintenance access should be at least 12 feet wide, have a maximum slope of no more than 15%, and be appropriately stabilized to withstand maintenance equipment and vehicles.
- The maintenance access should extend to the forebay, safety bench, outlet control structure, and outlet and be designed to allow vehicles to turn around.

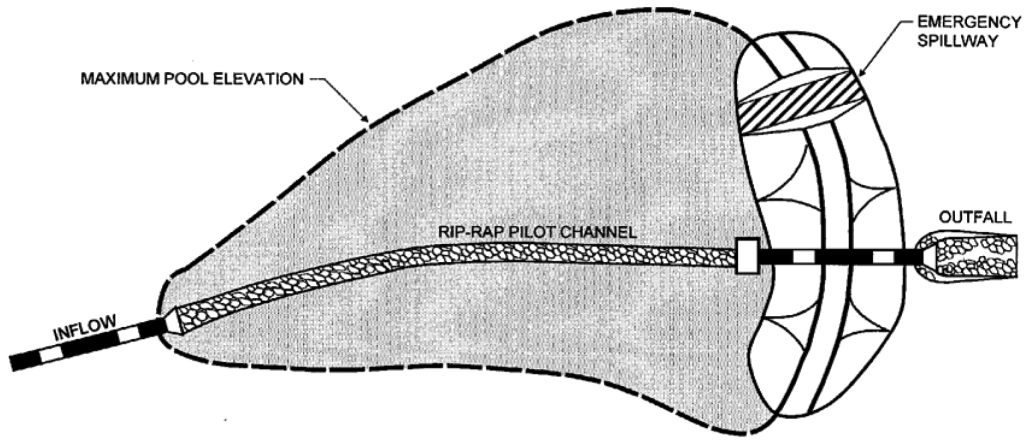

**PLAN VIEW**

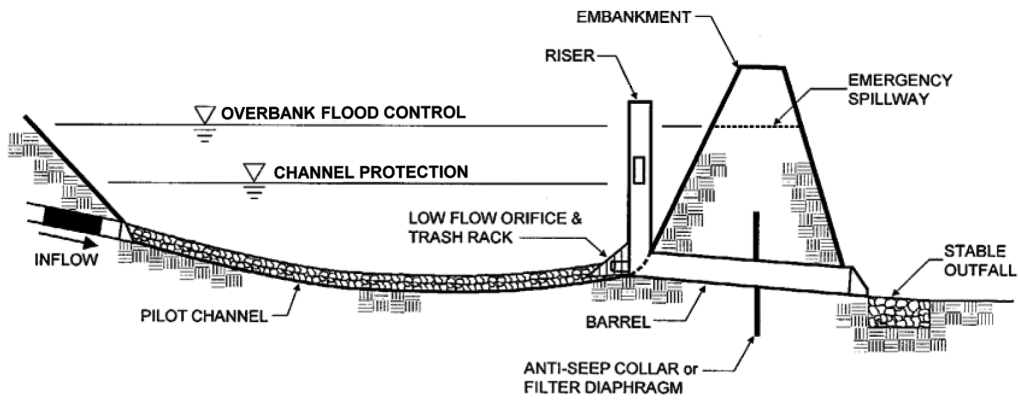

**PROFILE**

Figure 5.22 Dry Extended Detention Basin (from RIDEM and CRMC, 2015 – Adapted from MDE, 2000)

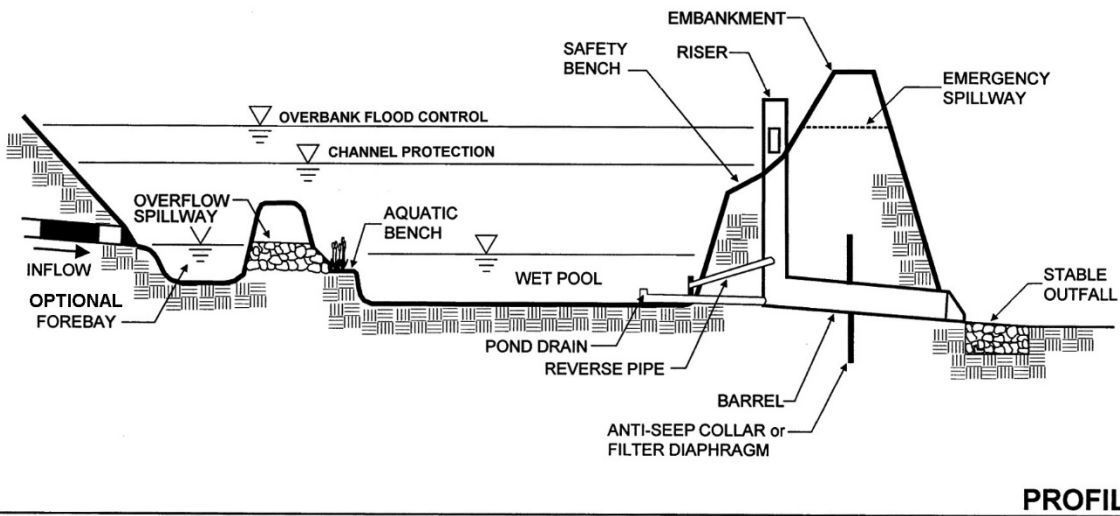
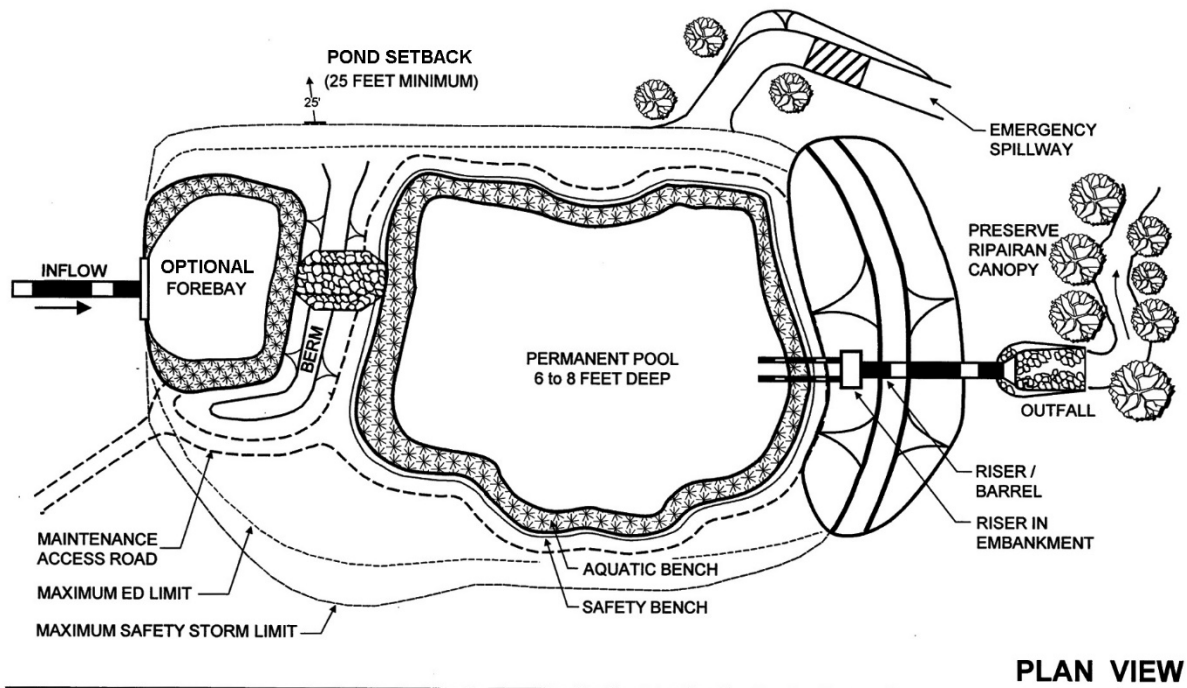

Figure 5.23 Wet Extended Detention Basin (from RIDEM and CRMC, 2015 – Adapted from MDE, 2000)

## UNDERGROUND STORAGE DEVICES

*Underground storage* practices capture and store treated stormwater from a site, slowly releasing it back to a natural channel or receiving waters at pre-development peak flows. While these underground storage *vaults, chambers, or pipes* provide minimal, if any, stormwater quality benefits, they can be used to meet gut protection ( $G_p$ ) and overbank flooding ( $Q_p$ ) standards (SW-4 and 5).

Subsurface storage structures are typically made of concrete (vaults) or large diameter, rigid pipes or arches with capped ends and made of plastic, steel or aluminum. Storage structures and appurtenances (inlet and outlet pipes, maintenance access/manholes) are constructed in a predetermined excavated area sized for the required criteria ( $G_p$  and  $Q_p$ ). The entire area is then back-filled with gravel to surrounding grades and surfaced. Due to on-going maintenance requirements and the potential need for repairs, underground storage facilities should not be built over and should be located in areas where large-sized maintenance vehicles can easily operate and excavate, if required.

Underground storage is most often used at sites where land availability, shape, and/or land costs preclude or discourage the development of surface stormwater storage. Underground storage is ideal for use under parking lots, roadways and paved areas associated with commercial, industrial and residential developments. The advantages of an underground storage facility are (1) rapid installation using prefabricated modular systems; (2) systems are durable with a long life (50 years plus for most systems); (3) increased level of public safety vs. open, deep storage basins; and (4) efficient use of space in urban areas and for retrofits. Limitations of underground systems include that they often require extensive, costly excavation; material costs are high compared to surface methods; and maintenance costs are higher. In addition, routine maintenance is often overlooked because the practice is not easily inspected via casual observation.

### Feasibility

- Designers shall check with local authorities regarding design requirements and necessary permits for construction of underground storage. There is great variability between localities in

requirements and permissible construction materials.

- Placement of underground stormwater storage is site specific. During early site inspections, special note should be made of site size, shape, and physical characteristics of the landscape. These factors will help determine basic structure of the detention system and what materials are best used in construction.
- The suggested maximum area of stormwater drainage to be collected for one underground storage system is 25 acres.
- Underground storage devices have confined entry limitations per Occupational Safety and Health Administration (OSHA) regulations.

### Minimum Plan Requirements

The following items must be shown on the design plans and/or included in the technical specifications:

- Location of all underground storage systems on the site plan
- Details showing pipe and storage connections, storage structures size and dimensions, and other key components
- Installation methods and sequencing
- Specifications for materials

### Material Selection

Site-specific conditions can influence which materials are selected:

- Depth and area of excavation: deeper and larger excavated areas require more fill for maintaining the integrity of plastic or metal pipe;
- Shape of space: continuous space allows for the use of concrete, while angular spaces favor the use of pipe systems. However:
  - Pipes store less water than square concrete vaults per unit of land surface.
  - Pipes require more fill than concrete structures, thus using more excavated area.
  - Use the largest pipe diameter possible. Doubling pipe diameter quadruples capacity and only doubles cost.

## Conveyance

Outfalls to the ground surface, where needed, shall be constructed such that they do not increase erosion by discharging near bottom of the slope or into an energy dissipating step-pool arrangement.

An emergency overflow system shall be designed to convey flows larger than the 100-year storm or to divert water in case system fails for any reason.

If system discharges to a gut, care should be taken to minimize tree clearing along the downstream channel, and to reestablish a forested riparian zone in the shortest possible distance.

## Pretreatment

Pretreatment is not typically required since full pretreatment/treatment must be provided by upstream SCMs.

## Design

- Capacity and discharge rate shall depend on the  $G_p$  and  $Q_p$  requirements. Storage is a function of geometry of the structure, which shall be provided by the manufacturer. This SCM cannot be used to meet runoff reduction or water quality requirements.
- It is generally desirable to provide the upstream runoff reduction/water quality treatment off-line when topography, head, and space permit.
- Sufficient maintenance access points (manholes) shall be incorporated in design to facilitate easy maintenance. Placement shall, at a minimum, occur near the intake and another at the outlet end of the system. The number of manholes depends on maintenance methods used.
- The design shall address implications of the depth to groundwater at the site. A high water table can cause structures to displace due to uplift forces if not designed correctly. Anti-floatation calculations are required when system designed below the water table.

- If system outfalls to ground surface, outfall protection (stone apron or level spreader) may be required and should be sized properly to reduce erosion.
- Pipes and floors of vaults should be designed with a maximum of two percent slope.

## Maintenance

- Periodic inspections (i.e., quarterly) of the inlet and outlet areas to ascertain correct operation of system and to clean materials trapped on grates protecting catch basins and inlet area.
- Sediment shall be removed from the system when the sediment volume exceeds 10% of the total vault volume and should be disposed of according to an approved comprehensive operation and maintenance plan.
- The primary maintenance concerns are removal of floatables that become trapped and removal of accumulating sediments within the system; this should be done at least on a bi-annual basis. Proprietary traps and filters associated with stormwater storage units should be maintained as recommended by the manufacturer.
  - Confined space safety procedures as required by OSHA regulations must be followed by workers entering an underground stormwater storage facility because noxious gasses may form in the system.
  - Sediments are best removed mechanically rather than flushing. If flushing is the only option, then great care must be taken not to flush sediments downstream into the receiving waters.
- Any structural repairs required to inlet and outlet areas should be addressed in a timely manner on an as-needed basis.

*Much of this section was adapted from Lakesuperiorstreams (2005).*



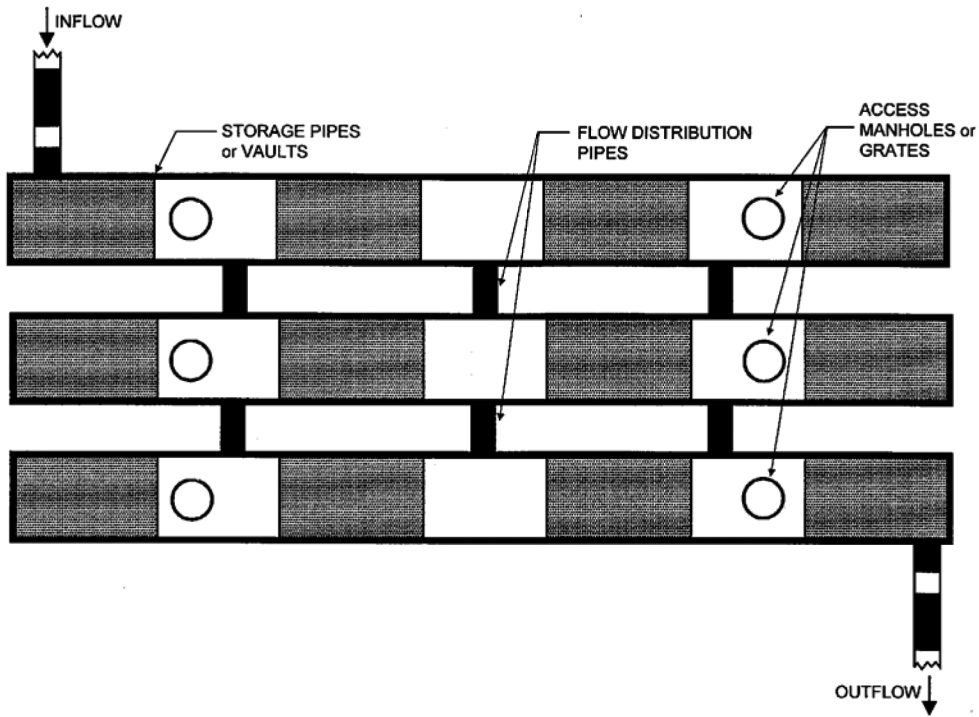

**PLAN VIEW**

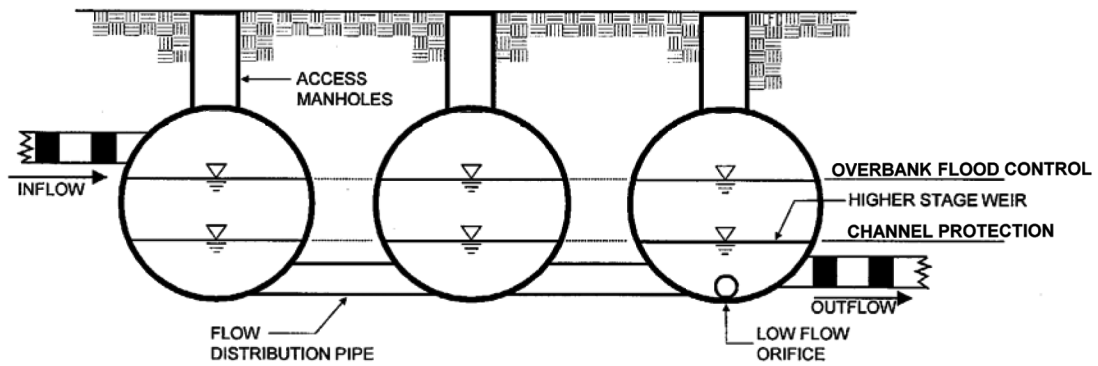

**TYPICAL SECTION**

Figure 5.24 Example Underground Storage Vault (from RIDEM and CRMC, 2015 – Adapted from VTANR, 2002)



# R

## REFERENCES

AGH Industries, Inc. 1999. EnviroGrid Cellular Confinement System Specifications, AGH Industries, Inc. Fort Worth, Texas, [www.aghindustries.com](http://www.aghindustries.com).

American Rivers. 2022. What is Green Infrastructure? <https://www.americanrivers.org/threats-solutions/clean-water/green-infrastructure/what-is-green-infrastructure/>.

Berkshire Regional Planning Commission. 2001. The Massachusetts Unpaved Roads BMP Manual: A Guidebook on How to Improve Water Quality While Addressing Common Problems. [www.mass.gov/eea/docs/dep/water/resources/a-thru-m/dirtroad.pdf](http://www.mass.gov/eea/docs/dep/water/resources/a-thru-m/dirtroad.pdf)

Bruno, J., Petes, L., Harvell, C., & Hettinger, A. (2003). Nutrient enrichment can increase the severity of coral diseases. *Ecology Letters*, 1056-1061.

Campbell, S. E. (2017). The effect of watershed runoff and sediment resuspension on turbidity and sediment deposition in St. John, US Virgin Islands: Implications for watershed and marine development and restoration in bays with coral reefs. Retrieved from <https://digital.sandiego.edu/theses/22>

Center for Dirt and Gravel Road Studies. 2017. Driving Surface Aggregate Handbook. Penn State University. [www.dirtandgravel.psu.edu/general-resources/driving-surface-aggregate-dsa](http://www.dirtandgravel.psu.edu/general-resources/driving-surface-aggregate-dsa)

Center for Dirt and Gravel Road Studies. 2012. Environmentally Sensitive Maintenance Practices for Dirt and Gravel Roads. Penn State University. [www.fs.fed.us/eng/php/library\\_card.php?p\\_num=1177%201802P](http://www.fs.fed.us/eng/php/library_card.php?p_num=1177%201802P)

Center for Watershed Protection and Horsley Witten Group, Inc. 2010. Island stormwater practice design specifications: A supplement to the 2006 CNMI and Guam stormwater design manual.  
[https://www.ncei.noaa.gov/data/oceans/coris/library/NOAA/CRCP/project/1906/island\\_swm\\_specs\\_supplement\\_cnmi\\_guam\\_design.pdf](https://www.ncei.noaa.gov/data/oceans/coris/library/NOAA/CRCP/project/1906/island_swm_specs_supplement_cnmi_guam_design.pdf)

Center for Watershed Protection (CWP). 2001. "Aquatic Buffers Fact Sheet: Buffer Zones," Stormwater Managers Resource Center, [www.stormcenter.net](http://www.stormcenter.net), Ellicott City, Maryland.

Center for Watershed Protection (CWP). 2001. Stormwater Management Factsheet: Infiltration Trench. Stormwater Manager's Resource Center, Ellicott City, MD. [www.stormwatercenter.net](http://www.stormwatercenter.net)

Center for Watershed Protection (CWP). 2001. Stormwater Management Factsheet: Grass Channel. Stormwater Manager's Resource Center, Ellicott City, MD. [www.stormwatercenter.net](http://www.stormwatercenter.net)

Center for Watershed Protection (CWP). 2001. Stormwater Management Factsheet: Bioretention, Stormwater Manager's Resource Center. Ellicott City, MD. [www.stormwatercenter.net](http://www.stormwatercenter.net)

Center for Watershed Protection (CWP), Environmental Quality Resources and Loiederman Associates. 1998. Maryland Stormwater Design Manual, Draft. Prepared for: MD Department of the Environment, Baltimore, MD.  
[www.mde.state.md.us/environment/wma/stormwatermanual/mdswmanual.html](http://www.mde.state.md.us/environment/wma/stormwatermanual/mdswmanual.html).

CH2M Hill. 1998. Pennsylvania Handbook of Best Management Practices for Developing Areas, Pennsylvania Association of Conservation Districts, Harrisburg, Pennsylvania.

City of Austin, Texas. 1991. IN: Schueler, T.R. 1994. "Developments in Sand Filter Technology to Improve Stormwater Runoff Quality," Watershed Protection, 1(2):47-54, Center for Watershed Protection, Silver Spring, Maryland.

City of Austin, Texas. 1991. Design Guidelines for Water Quality Control Basins, Public Works Department, Austin, Texas.

Coral Bay Community Council (CBCC). 2021. Coral Bay St. John USVI 2021 Watershed Management Plan: Phase 3 - Our Future Based on Balancing Environmental Protection & Development: Local Actions to Improve Water Quality and Protect Coral Reef Habitats from Destructive Byproducts of Development

Coral Bay Community Council. 2017. Vegetation for Erosion Control—A Manual for Residents. <http://coralbaycommunitycouncil.org/landscaping-sediment-reduction/>

Department of Planning and Natural Resources (DPNR). 2020. The 2020 USVI Integrated Water Quality Monitoring & Assessment Report. 92 pp.

Dunne T. and L.B. Leopold, 1978. Water in Environmental Planning, WH Freeman and Company, New York, NY.

Empire State Chapter, Soil and Water Conservation Society. 1997. *New York Guidelines for Urban Erosion and Sediment Control Update*, Syracuse, New York. In cooperation with USDA Soil Conservation Service.

Fabricius, K.E., De'ath, G., 2004. Identifying ecological change and its causes: a case study on coral reefs. *Ecological Applications* 14, 1448–1465.

FAO Road Construction Techniques [www.fao.org/docrep/006/T0099E/T0099e06.htm](http://www.fao.org/docrep/006/T0099E/T0099e06.htm)  
FEMA Interagency on Dam Safety. 2004. Federal

Guidelines for Dam Safety. 66pp  
[https://www.fema.gov/sites/default/files/2020-08/fema\\_dam-safety\\_P-93.pdf](https://www.fema.gov/sites/default/files/2020-08/fema_dam-safety_P-93.pdf)

Filtrexx Design Specifications for Perimeter Control: Compost Filter Sock. In Filtrexx Design Manual Vol 1. 11 pp.  
[https://www.filtrexx.com/application/files/4816/2022/0401/1.1\\_Filtrexx\\_Perimeter\\_Control.pdf](https://www.filtrexx.com/application/files/4816/2022/0401/1.1_Filtrexx_Perimeter_Control.pdf)

Gray, S. C., Smith, T., Taylor, M., Henderson, L., Hastings, Z., Sears, W., & Przyuski, N. (2012). *Marine monitoring of sedimentation below erosion mitigation projects in Coral Bay, Fish Bay, and East End St. Croix, USVI*. Virgin Islands Resource Conservation & Development Council Inc.

Halsted, G., W. Adaska, W. McConnell. 2008. *Guide to Cement-Modified Soil. (CMS)*, EB242 Portland Cement Association, Skokie, IL, 20 pp.

Halsted, G., D. Luhr, W. Adaska. 2006. *Guide to Cement-Treated Base (CTB)*, EB236 Portland Cement Association, Skokie, IL, 20pp.

Howe, A., Forster, S., Morton, S., Marshall, R., Osborn, K., Wright, P., & Hunter, P. (2002). Cryptosporidium oocysts in a water supply associated with a cryptosporidiosis outbreak. *Emerging Infectious Diseases*, 619-624.

Horsley Witten Group, Inc. (HW). 2009. Erosion Control Field Guide for the CNMI. Prepared for CNMI Bureau of Environmental and Coastal Quality.

Horsley Witten Group and Center for Watershed Protection Inc. (2014). Stormwater management in Pacific and Caribbean Islands: A practitioner's guide to implementing LID. prepared for NOAA Coral Reef Conservation Program. 186 pp. <https://www.coris.noaa.gov/activities/stormwater/lid/>

ICMA. 2014. Three Strategies for Advancing Social Equity and Increasing Community Sustainability. [www.icma.org/articles/article/three-strategies-advancing-social-equity-and-increasing-community-sustainability](http://www.icma.org/articles/article/three-strategies-advancing-social-equity-and-increasing-community-sustainability)

Kitchell, A., B. Kuchar, and R. Viqueira Ríos. 2021. Unpaved Road Standards for Caribbean and Pacific Islands. Prepared for the NOAA Restoration Center and Coral Reef Conservation Program. 71 pp. [https://www.ncei.noaa.gov/data/oceans/coris/library/NOAA/CRCP/NMFS/OHC/Projects/30033/HorsleyWittenGroup2017 Island Unpaved Road Standards.pdf](https://www.ncei.noaa.gov/data/oceans/coris/library/NOAA/CRCP/NMFS/OHC/Projects/30033/HorsleyWittenGroup2017%20Island%20Unpaved%20Road%20Standards.pdf)

Maryland Department of the Environment, Water Management Administration. 1994. *1994 Maryland Standards and Specifications for Soil Erosion and Sediment Control*, Annapolis, Maryland. In cooperation with USDA Soil Conservation Service.

Maryland Department of the Environment. 1987. *Guidelines for Constructing Wetlands Stormwater Basins*, Sediment and Stormwater Administration, Annapolis, Maryland.

Maryland Department of the Environment. 1987. *Design Procedures for Stormwater Management Extended Detention Structures*, Sediment and Stormwater Administration, Annapolis, Maryland.

Nemeth, R.S. and Nowlis, J.S., 2001. Monitoring the effects of land development on the near-shore reef environment of St. Thomas, USVI. *Bulletin of Marine Science*, 69(2), pp.759-775.

New York State Department of Environmental Conservation. 1992. *Reducing the Impacts of Stormwater Runoff from New Development*, Division of Water, Bureau of Water Quality Management, Syracuse, New York.

NOAA, 2021. Threats to Coral Reefs: Land-based sources of pollution Infographic. <https://oceanservice.noaa.gov/facts/coral-pollution.html>

NRCS. 2015. Fact sheet: *Control Soil Erosion, Maintain and Improve Water Quality with Vetiver Barriers*

Oregon DEQ, 2024 [https://www.filtrexx.com/application/files/2514/6196/0979/7.25 - EPA National Menu of BMPs - Filter Socks.pdf](https://www.filtrexx.com/application/files/2514/6196/0979/7.25%20-%20EPA%20National%20Menu%20of%20BMPs%20-%20Filter%20Socks.pdf)

Pandey, P., Kass, P., Soupir, M., Biswas, S., & Singh, V. 2014. Contamination of water resources by pathogenic bacteria. *AMB Express*, 4, 51.

Presto Products Company. 1997. Metric GeoBlock® Porous Pavement System Installation Guideline, Presto Products Company, Appleton, Wisconsin, [www.prestogeo.com](http://www.prestogeo.com).

Ramos-Scharrón CE, MacDonald LH. 2005. Measurement and prediction of sediment production from unpaved roads, St. John, US Virgin Islands. *Earth Surface Processes and Landforms* 30: 1283-1304.

Ramos-Scharrón CE. 2012. Effectiveness of an erosion control method in reducing sediment production rates from an unpaved road. *Journal of Soil and Water Conservation* 67(2): 87-100.

Ramos-Scharrón C. and M. LaFevor, 2016. The role of unpaved roads as active source areas of precipitation excess in small watersheds drained by ephemeral streams in the Northeastern Caribbean. *Journal of Hydrology*. Vol 533: 168-179.

Ramos-Scharrón CE, Torres-Pulliza D, Hernández-Delgado EA. 2015. Watershed- and island wide-scale land cover changes in Puerto Rico (1930s-2004) and their potential effects on coral reef ecosystems. *Sci Total Environ*. 506-507:241-51.

Rao, G., Kahler, A., Voth-Gaeddert, L. E., Cranford, H., Libbey, S., Galloway, R., ... Elis, E.M., & Ellis, B. R. (2022). Microbial characterization, factors contributing to contamination, and household use of cistern water, US Virgin Islands. *ACS Es&t Water*, 2(12), 2634-2644.  
<https://doi.org/10.1021/acsestwater.2c00389>

Rawls, W. I., D. L. Brakensiek, and K. E. Saxton. 1982. Soil water characteristics. *Trans. ASAE*, 25(5):1316-1328.

Santiago-Rivera, Luis, and Colon-Dieppa, Eloy, 1986, U.S. Virgin Islands surface-water resources, in U.S. Geological Survey, National water summary 1985-Hydrologic events and surface-water resources: U.S. Geological Survey Water-Supply Paper 2300, p. 447-452.

Schueler, T.R. 1987. Controlling Urban Runoff: A Practical Manual for Planning and Designing Urban BMPs, Metropolitan Washington Council of Governments, Department of Environmental Programs, Washington, DC. Publication Number 87703.

Schueler, T. R., and J. Lugbill. 1990. Performance of current sediment control measures at Maryland construction sites. Department of Environmental Programs, Metropolitan Washington Council of Governments, Washington, DC.

Schueler, T.R., P.A. Kumble, and M.A. Heraty. 1992. A Current Assessment of Urban Best Management Practices: Techniques for Reducing Nonpoint Source Pollution in the Coastal Zone, Anacostia Restoration Team, Metropolitan Washington Council of Governments, Department of Environmental Programs, Washington, DC. Publication Number 92705.

Schueler, T.R. 1994. "Developments in Sand Filter Technology to Improve Stormwater Runoff Quality," *Watershed Protection*, 1(2):47-54, Center for Watershed Protection, Silver Spring, Maryland.

Storlazzi, C. D., Reguero, B. G., Cole, A. D., Lowe, E., Shope, J. B., Gibbs, A. E., Beck, M. W. (2019). *Rigorously valuing the role of U.S. coral reefs in coastal hazard risk reduction*. Santa Cruz: Pacific Coastal and Marine Science Center, U.S. Geological Survey.

Stormceptor Corporation. 1997. Stormceptor® Technical Manual, Rockville, Maryland, [www.stormceptor.com](http://www.stormceptor.com).

Tetra Tech, 2015. Green Infrastructure Opportunities that Arise During Municipal Operations. Prepared for US EPA Office of Wetlands, Oceans, and Watersheds. EPA 842-R-15-002. <https://www.epa.gov/green-infrastructure/what-green-infrastructure>

Texas A&M Forest Service. 2013  
<http://tfswater.blogspot.com/search/label/Broad-Based%20Dip>

Thomas, T., & Devine, B. (2005). *Island peak to coral reef: A field guide to the plant and marine communities of the Virgin Islands*.

US Army Corps of Engineers. 2011. Regional Supplement to the Corps of Engineers Wetland Delineation Manual: Caribbean Islands Region (Version 2.0).  
<https://apps.dtic.mil/sti/citations/tr/ADA543979>

USDA Forest Service. 2008. Soil and Water Road-Condition Index-Field Guide.

USDA-NRCS. March 2019. Technical Release 210-60: Earth Dams and Reservoirs.

USDA-SCS Caribbean Area. 1993. Constructed Wetland Practice Specifications (DRAFT), from USDA Field Handbook, Puerto Rico.

USDA-SCS Caribbean Area. 1992. Tropical America Plant Material Center Long Range Plan: Puerto Rico and U.S. Virgin Islands (DRAFT), Puerto Rico.

USDA-SCS. 1990. *Field Office Technical Guide, Caribbean Area*, Section IV, U.S. Department of Agriculture Soil Conservation Service, San Juan, PR.

USDOT Federal Highway Administration, US Department of Transportation. 2015 Gravel Road Construction and Maintenance Guide.  
<https://www.fhwa.dot.gov/construction/pubs/ots15002.pdf>

US Environmental Protection Agency (EPA). 2016. What Climate Change Means for the US Virgin Islands. Factsheet. EPA 430-F-16-065.  
<https://19january2017snapshot.epa.gov/sites/production/files/2016-11/documents/climate-change-usvi.pdf>

U.S. EPA. 1993. Guidance for Specifying Management Measures for Sources of Nonpoint Pollution in Coastal Waters, U.S. Environmental Protection Agency, Office of Oceans, Wetlands and Watersheds, Washington, DC. Document Number 840-B-92-002.

U.S. EPA. 1992. Stormwater Management for Construction Activities: Developing Pollution Prevention Plans and Best Management Practices, U.S. Environmental Protection Agency, Office of Wetlands, Oceans and Watersheds, Washington, DC. Document Number 832-R-92-005.

U.S. EPA Design Manual: Constructed Wetlands and Aquatic Plant Systems for Municipal Wastewater Treatment Systems.

USGCRP, 2018: *Impacts, Risks, and Adaptation in the United States: Fourth National Climate Assessment, Volume II* [Reidmiller, D.R., C.W. Avery, D.R. Easterling, K.E. Kunkel, K.L.M. Lewis, T.K. Maycock, and B.C. Stewart (eds.)]. U.S. Global Change Research Program, Washington, DC, USA, 1515 pp. doi: 10.7930/NCA4.2018.  
<https://nca2018.globalchange.gov/#sf-1>

Van Beukering, P.J.H., L. Brander, B. van Zanten, E. Verbrugge and K. Lems (2011). The Economic Value of the Coral Reef Ecosystems of the United States Virgin Islands. Report number R-11/06.

Vermont Better Backroads Erosion Inventory Assessment Manual, 2015.  
<https://anrmaps.vermont.gov/websites/pdfs/Road%20Erosion%20Risk%20Manual.pdf>

Waddell. 2021. Addressing Inequities in Hazard Mitigation Planning in the USVI. NOAA in the Caribbean Biannual Meeting September 22, 2021





# A

## APPENDIX A

### STORMWATER STANDARDS CHECKLIST

The purpose of this checklist is to ensure that engineers and designers are familiar with the EPH Stormwater Standards listed in **Chapter 2**; that the LID site design strategies for runoff reduction described in **Chapter 3** were applied; and that the structural stormwater control measures proposed meet the criteria established in **Chapters 4** and **5**.

This checklist should be completed by the applicant to ensure that the proposed stormwater management plan includes all the documentation permit reviewers need to confirm compliance with the standards.

Stormwater requirements will vary from project to project, it is possible that a complete permit application may not include information on some of the items specified in the Checklist. If a specific item does not apply to the project under review, please note that the item is not applicable (N.A.) and provide the reasons for that determination.

# CHECKLIST FOR EROSION & SEDIMENT CONTROL STANDARDS

There are 11 ESC standards intended to help minimize the impact on downstream properties, infrastructure, and ecological communities of site erosion and sedimentation during construction. This checklist should accompany your earth change permit application or other required stormwater reports.

## ESC-1 ESC Plan and Sequencing

- There is a separate, stand-alone, stamped plan sheet for Erosion and Sediment Control as part of the plan set submitted for Earth Change, TPDES, or other permitting applications. *If an ESC plan is not provided, explain why it is not needed in the box below.*

The ESC plan includes:

- Name of watershed and list of any receiving waters currently impaired for turbidity (see latest Integrated Waters report from DPNR).
  - Site topography (at least 2-foot contours required). 10-foot contours accepted for off-site areas.
  - Locations of drainage paths, extent of existing vegetation, resource areas, and their regulated setbacks.
  - Information on demolition, tree removal, and associated rough grading during various phases of site clearing.
  - Location, sizing, and typical details of proposed ESC practices (limits of disturbance, perimeter controls, conveyance structures, sediment traps, inlet/outlet protection).
  - Information on seeding or other temporary stabilization practices.
  - Staging and stockpiling areas.
  - Construction notes that include basic sequencing, inspection during installation, and maintenance (unless this is included in an associated Stormwater Pollution Prevention Plan SWPPP).
  - VI-licensed engineer stamp.
- There is a narrative description to accompany the ESC plan that describes:
    - Proposed temporary practices (e.g., perimeter controls, conveyance structures, sediment traps);
    - Construction sequence specifying the installation timing of ESC practices prior to and after site clearing;
    - Locations where site drainage outlets into waterways, onto adjacent properties, or public roads and a description of how ESC practices will prevent those impacts.

*Identify where the narrative can be found (i.e., page # in what permit application, see SWPPP under the TPDES permit) or explain why it is not provided in the box below.*

## ESC-2 Resource Protection

To protect important natural resources during construction, site surveys should locate the following and add to site plans):

- Location and field-verified boundaries of resource protection areas such as perennial and intermittent drainage channels (guts), freshwater and coastal wetlands, salt ponds, and coastal shoreline features with mean high water.
- Location of required setbacks from resource areas and other features (e.g., buffers, water supply wells, septic systems).
- Location of floodplain and, if applicable, floodway limits and relationship of site to upstream and downstream properties and drainages.
- Location of sea level rise inundation line for at least a 50-yr horizon.
- Boundaries of existing predominant vegetation and proposed limits of clearing; include location of existing trees (>6" diameter) and trees proposed for removal.
- Limits of disturbance.
- Location and dimensions of channel modifications, such as bridge or culvert crossings are provided.

Standard not applicable , explain why:

## ESC-3 Clearing and Grading

The purpose of this standard is to minimize unnecessary land clearing.

- Limits of disturbance are shown on the plan and reflect consideration of how to minimize unnecessary clearing and grading. Describe how wide the clearing envelope is around structures, roads, and other development features and how this standard is being met (or not met).

- Proposed ESC measures will be installed prior to extensive site clearing.
- There is a plan for separating, stockpiling, and reusing valuable topsoil that will be removed during grading. Where is this information provided?
- Cut and fill estimates calculated based on the grading plan are provided.
- The number and species of trees >6-inch diameter that will be removed has been provided.
- Construction activities are scheduled to minimize soil exposure by avoiding the wet season.

Standard not applicable , explain why:

### ESC-4 Soil Stabilization

The purpose of this standard is to stabilize exposed soils for duration of project to minimize erosion.

- The site plan and construction schedule clearly indicate that disturbed areas will be stabilized where construction activities will be paused for more than 14 days.
- Construction phasing limits disturbance to only one area of active construction at a time to reduce the total area requiring temporary stabilization. *If phasing is not included, explain why:*

- Construction sequencing includes instructions for when to remove ESC practices.

Standard not applicable , *explain why:*

### ESC-5 Slope Protection

A steep slope is defined as any slope over 20% (5:1) in grade over a length of 50 feet.

- Steep slopes in need of extra protection are identified in the ESC plan. Describe protection measures provided or where narrative can be found:

Standard not applicable , *explain why:*

### ESC-6 Perimeter Controls

The intent of this standard is to prevent sediment laden runoff from leaving the site.

- Confirm that perimeter controls are to be installed prior to extensive site clearing and that the installation of these measures will not impact adjacent properties or resources.
- The locations and descriptions of perimeter controls are shown on site plan and described in the narrative.
- Washpads and other containment devices used for equipment cleaning, concrete truck cleanouts, and dewatering are designed to prevent off-site discharge.
- Locations where offsite discharge occurs are identified in the O&M plan for routine inspection.

Standard not applicable , explain why:

### ESC-7 Settling Devices

This standard only applies to sites where settling devices are being used.

- Sediment traps, basins, or other proposed devices to collect and retain sediment-laden runoff are sized to hold at least 1 inch of runoff from the contributing drainage area (3,600 cubic feet per acre).  
*Where can the calculations and drainage area maps be found?*

- Embankment design standards are met to meet performance safety standards.
- The locations and descriptions of settling devices are shown on site plan and described in the narrative.
- The O&M plan includes removal of accumulated sediments once ½ capacity is filled.
- If basin will be used for post-construction stormwater management, there is a conversion plan that includes re-establishing design geometry (may also require over-digging of bottom to remove any accumulated fine sediments that may prevent any infiltration).

Standard not applicable , explain why:

### ESC-8 Conveyance Structures

This standard is only applicable to sites where conveyance features are used to move runoff around a construction site.

- Conveyance structures are designed to handle the peak flow from the 10-year, 24-hour Type II storm event for all contributing drainage area, at a minimum.
- The locations and descriptions of conveyance structures are shown on site plan and described in the narrative.
- Natural guts are not used as temporary conveyances for construction site runoff.
- Diversion and outlet protection practices are stabilized to prevent erosion from concentrated flows through and around the site (e.g, check dams, liners, stone protection, energy dissipators).

Standard not applicable , explain why:

### ESC-9. Education and Training

This standard is intended to ensure that construction contractors are knowledgeable about the site-specific ESC plan.

- A description is provided on how the following will be implemented once a construction contractor is selected:
  - The selected site manager will provide documentation certifying they have received ESC training in the past and that they are familiar with the ESC practices described in the EPH and how they function; and
  - Equipment operators and other site personnel will be educated on site on the proper application and maintenance of ESC practices for that project site.

Standard not applicable , *explain why:*

### ESC-10. Practice Maintenance

The purpose of this standard is to ensure that ESC practices work as intended through all phases of construction.

- There is an O&M plan guiding inspection and maintenance activities for all ESC practices that will be available on site throughout construction.
- There is an enforceable O&M agreement signed by the designated site manager or construction supervisor.
- The plan includes guidance on what to do with disposal of accumulated sediments (i.e., not thrown in the gut).

Standard not applicable , *explain why:*

### ESC-11. Performance Accountability

Ensure approved plan is working as intended during all phases of construction.

- There is a defined process to amend the ESC plan if it is found that additional measures are required or that some of the implemented measures are not working.

Standard not applicable , *explain why:*

## POST-CONSTRUCTION STORMWATER STANDARDS

The 10 post-construction stormwater management standards are intended to establish VI-specific requirements for site design and permanent stormwater control measures (SCMs) as they relate to the generation and management of stormwater, respectively. The goals of post-construction stormwater management are to: reduce runoff volume, remove pollutants, and prevent erosion and flooding.

### SW-1.No Unmanaged Runoff

The objective is to ensure that regulated development projects address their stormwater runoff.

Project type:

- New development
- Mix of new and redevelopment
- Redevelopment
- Retrofit
- No new untreated discharges are proposed.
- Discharges to regulated critical areas  exist OR  do not exist. If so, any additional management criteria and methods to meet them are described. *Describe here or identify where the description can be found:*

- Table provided that clearly identifies the breakdown of new vs. redevelopment acres within the site.
- New development meets Stormwater Standards 2-10.
- Redevelopment projects meet Standards 2, 3, and 7-10 using which of the following strategies:
  - Reduce existing impervious area by at least 50% of the redevelopment area; or
  - Use on-site, non-structural or structural SCMs to provide reuse, recharge, and water quality management for at least 50% of redevelopment area (Standards 2 and 3).
  - Proposed alternatives to achieve an equivalent pollutant reduction using a combination of SCMs and strategies for treating 100% of the redevelopment area by SCMs with a lesser pollutant removal efficiency than stipulated in Standard 3.
  - Off-site SCMs are implemented at an approved off-site location in the same watershed for an area  $\geq$  50% of redevelopment area AND applicant has:
    - Demonstrated that impervious area reduction, non-structural, and/or structural SCMs have been implemented to the maximum extent practicable on-site.
    - Described specific management measures.
    - Provided an implementation schedule developed in accordance with agency review.
    - Demonstrated that there will be no downstream drainage or flooding impacts from the project site for large storm event due to an inability to meet on-site standards.
- Supporting calculations have been provided. *Identify where they can be found:*

## SW-2. Runoff Reduction

The intent is to reduce the total volume of runoff produced at the site using a combination of LID site planning, non-structural, and structural control measures. If this standard is met, no additional measures are needed to meet standards 3 and 4.

- There is no discharge from the 1-year, 24-hour Type II design storm (i.e., the entire runoff volume is reused, infiltrated, evaporated, or otherwise retained on site).

If this standard has not been fully met, a description has been provided explaining why and what is proposed for mitigation (*either describe here or indicate where the description can be found*):

- Designers have used the most updated rainfall data and approved models for determining the runoff volume, and the supporting calculations have been provided. *Identify where they can be found:*

- As part of the design process, the applicant has included the following LID measures and/or methods:

- Protect as much undisturbed open space as possible to maintain pre-development hydrology and allow precipitation to naturally infiltrate into the ground. *Describe how this method was applied or why it was not:*

- Minimize soil compaction and restore soils compacted due to construction activities or prior development. *Describe how this method was applied or why it was not:*

- Provide low-maintenance, native vegetation that encourages retention and minimizes the use of lawns, fertilizers, and pesticides. *Describe how this method was applied or why it was not:*



- Minimize impervious surfaces. *Describe how this method was applied or why it was not:*

- Break up or disconnect the flow of runoff over impervious surfaces. Drainage maps have been provided. *Describe how this method was applied or why it was not:*

- Manage precipitation as close as possible to the point it reaches the ground. *Describe how this method was applied or why it was not:*

- Use practices that maximize rainwater harvesting (reuse), infiltration, and/or evapotranspiration. *Describe how this method was applied or why it was not:*

- The site  is/  is not in a recharge area. If so, it:
  - has adequately met infiltration and pretreatment requirements, or
  - has requested or obtained a waiver.

Site plans contain:

- Name of watershed and list of any impaired receiving waters and pollutant of concern (see latest Integrated Waters report from DPNR) are provided.
- Location, size, and limits of proposed LID planning and site design techniques (type of practice, depth, area). LID techniques should be labeled clearly on the plan and a key should be provided that corresponds to a tabular description.
- Landscape planting plan.
- Soils information from test pits or borings at the location of proposed stormwater management facilities, including but not limited to soil descriptions, depth to seasonal high groundwater, depth to bedrock, and estimated hydraulic conductivity.
- Mapping of predominant soils from USDA soil surveys, especially hydric soil groups as well as

location of site-specific borings and/or test pits (can be separate figure from site plans)

- Existing and proposed drainage area delineations and drainage flow paths. Drainage area boundaries need to be complete; include off-site areas in both mapping and analyses, as applicable (can be separate figure from site plans).

### SW-3. Water Quality

This standard encourages the design of SCMs to remove pollutants and provide recharge for runoff from the first inch of rain (90<sup>th</sup> percentile storm).

- This standard is met through compliance with Standard 2 Runoff Reduction (no additional calculations or SCMs needed).
- The required water quality volume (WQv) is managed, and sufficient information is provided to confirm (e.g., calculations, updated precipitation estimates, drainage area maps). *List the target WQv and the actual volume managed. If not met, explain why not.*

- The proposed SCMs used to meet water quality volume requirement are listed in EPH **Chapter 5, Table 5.1** as being acceptable for treatment and are designed based on design criteria and are presumed to achieve stated pollutant reductions.
- Additional pollutant-specific requirements and/or pollutant removal efficiencies applicable to the site as the result of TMDL or other watershed-specific requirements are addressed.
- All SCM locations are shown on site plans with the essential invert elevations, dimensions, and details needed to document positive drainage and compliance with design criteria.
- Discharges are within or near:
  - A Wellhead Protection Area
  - other critical areas
  - soils with a rapid infiltration rate (greater than 2.4 inches per hour)
- SCM involves treatment of runoff from land uses with higher potential pollutant loads.

Standard not applicable , *explain why:*

#### SW-4. Gut Protection

This standard is intended to minimize the erosive discharges into natural guts and drainageways by providing 24 hours of extended detention storage for runoff from the 1-year, 24-hour Type II design storm event.

- This standard is met through compliance with Standard 2 Runoff Reduction (no additional calculations or SCMs needed).
- The required minimum gut protection volume ( $G_{pv}$ ) is managed, and sufficient information is provided to confirm (e.g., calculations, drainage area maps). *List the target  $G_{pv}$  and the actual volume managed. If not met, explain why not.*

- The proposed SCMs used to meet the gut protection requirement are listed in EPH **Chapter 5, Table 5.1** as being acceptable and are designed based on design criteria.
- Outfalls are properly stabilized to prevent erosion.

Standard not applicable due to absence of gut discharge or direct coastal discharge , *explain why:*

#### SW-5. Conveyance

To ensure that pipes and other conveyances are big enough to handle drainage safely, this standard requires peak flow management of the 25-year, 24-hour Type II design storm event from the entire contributing drainage area.

- Standard compliance has been demonstrated. *If not, explain why.*

- Culverts, pipes, and open channels are shown on the site plan and flow and sizing calculations are provided to confirm compliance.

- Conveyance structures were upsized to account for increased frequency of higher intensity storms. *Describe.*

- A factor of safety was applied to modeled flow estimates.
- Drainage area maps with flow paths are provided and include offsite contributing areas and projected build out, if applicable.

- A description of flow paths during the 100-year, 24-hour Type II design storm event is provided to demonstrate safe conveyance.

Standard not applicable , *explain why:*

### SW-6. Overbank Flooding

This standard helps to minimize additional contributions to downstream flooding from development at the site by matching predevelopment runoff rates for the 10-year and 100-year, 24-hour Type II design storm events (i.e., matching peak flows not volumes).

- The overbank flooding standard has been met, and sufficient information is provided to confirm (e.g., calculations using updated rainfall and approved models). *List the required and provided storage volumes and matching peak flows. If standard not met, explain why and how deficiencies can be addressed.*

- The proposed SCMs are located on the site plans and sufficient information is provided (e.g., dimensions, elevations, and details) on the practice, embankments, and outlet control structures to confirm compliance with design criteria.
- Modeling includes off-site contributing areas and anticipated future buildout conditions.
- The proposed SCMs used to meet the overbank flooding requirements are listed in EPH **Chapter 5, Table 5.1** as being acceptable and are designed based on design criteria.
- Runoff from the site for storms up to the 100-year, 24-hour Type II design storm events reaches the proposed SCMs designed to meet this standard.

Standard not applicable due to direct coastal discharge or other reason , *explain why:*

### SW-7. Operation/Maintenance

The objective of this standard is to help ensure that approved practices function as intended throughout their design life.

- An enforceable operation and maintenance plan and agreement has been provided that includes the following:
  - Identification of the stormwater management system's owner and individual responsible for operation and maintenance.
  - Description of the stormwater management system and the requirements for proper operation and maintenance.
  - Description of applicable easements.
  - A routine and annual maintenance plan for each post-construction SCM.
  - A maintenance log for tracking inspections and repairs.
  - A plan that is drawn to scale and shows the location of all stormwater SCMs and discharge points.
  - A description and map of public safety features.
  - An annual budget for operations and maintenance activities and equipment.

Standard not applicable , explain why:

### SW-8. Pollution Prevention

The purpose of this standard is to prevent, to the maximum extent practicable, pollutants that are present on site from coming into contact with stormwater.

- A stormwater pollution plan is provided (including SWPPPs under TPDES permits).
- Source control techniques such as dumpster covering, street sweeping or pet waste management have been proposed. *Describe proposed measures.*

Standard not applicable , explain why:

### SW-9. Pollutant Hotspots

This standard requires applicants to take extra effort when designing stormwater systems for land uses with a higher pollutant loading potential to ensure adequate treatment and to protect groundwater.

- Land use at site  is or  is not considered a stormwater hotspot. If so, it is a:
  - industrial sites subject to TPDES Multi-Sector General Permit (e.g., mining, landfill, power plant, wastewater treatment).
  - Fueling facilities.
  - Exterior vehicle service, maintenance, and equipment cleaning areas (including boat yards).
  - Outdoor storage and loading/unloading of hazardous substances.
  - Other.
  
- Pollutants of concern at the hotspot is documented and SCM selected to specifically address that pollutant. SCMs selected are sector-specific practices listed in the TPDES Multi Sector General Permit (MSGP), as applicable.
  
- Stormwater from a hotspot land use is not recharged to groundwater without adequate treatment, as determined by the approving agency (applies only to stormwater discharges that come into contact with the area or activity on the site that may generate higher potential pollutant load).
  
- In the areas where infiltration is not appropriate, other stormwater practices from **Chapter 5** can be used if they are lined (e.g., lined bioretention areas).

### SW-10. Illicit Discharges

This standard prevents the unintended discharge of wastewater (grey or black) to the stormwater drainage system.

- Applicant asserts that no illicit discharges exist or are proposed to the stormwater management system.

## UNPAVED ROAD STANDARDS

The 10 standards for unpaved roads are intended to ensure better drainage design to reduce erosion and maintenance frequency of unpaved road surfaces. This checklist is used to document compliance with these standards.

### UR-1. Controlled Runoff

The purpose of this standard is to eliminate unmanaged discharges from new unpaved roads and to bring existing roads that discharge muddy runoff into compliance when they undergo significant maintenance or repair.

Type

- New unpaved road (temporary). When is the anticipated time of paving?
- New unpaved road (long-term)
- Existing unpaved road (maintenance or repair)
- Driveway

All standards  are or  are not being met. *If not, provide rationale for deficiencies:*

- The contributing drainage area is delineated to key discharge points from the road and control practices are shown on the plan.
- The watershed name and any associated turbidity impairments for receiving waters are listed.

### UR-2. Upgradient Disconnection

Minimize the amount of runoff coming onto the road from connecting tie-ins (e.g., driveways and other roads), impervious cover, and surrounding hillsides.

- Up-gradient impervious cover has been disconnected from the road surface through the use of interceptor ditches, berms, or slope contouring that directs flows to pervious areas or stormwater practices.
- Tie-ins connecting to an existing unpaved road disconnect their drainage to reduce additional flow.
- Not applicable or not addressed. Explain why:

### UR-3. Road Width

Minimize the width of driving lanes to reduce the overall footprint of unpaved surfaces and the amount of runoff that must be managed.

- Road design sections include dimensions of designated driving lanes, shoulders, ditches, and side slopes within the right-of-way.
- Single driving lane widths are 10 ft or less with pullouts to accommodate passing and turnarounds.
- If not able to meet this standard, an evaluation of traffic patterns and vehicular needs has been provided to justify a waiver.
- Maintenance plans and agreements include information to maintain the design road width during regrading.

### UR-4. Surface Pitch

This standard ensures that the appropriate cross-slope or pitch is provided for the drainage system to function properly.

- Design plans include road sections showing road shape and grade.
- Out-sloped and insloped roads have a 3-6% pitch.
- Crowned road sections have a 4-6% pitch.
- Road surfaces are elevated above drainage features to maintain positive drainage.
- Maintenance plans and agreements include information to communicate proper road pitch to equipment operators.

### UR-5. Unpaved Surface Restrictions

Avoid highly erodible unpaved roads on steep slopes and within sensitive buffer areas.

- Road layouts chosen to avoid or minimize steep unpaved segments (>20% grade). *If not, explain why:*
- Road segments >20% are paved. If not, stable aggregate surfacing or more frequent drainage controls have been applied.
- The shoreline and buffer/setbacks are shown on design plans, as well as flood hazard and 50-yr sea level rise boundaries, if applicable.
- Unpaved roads within 200 ft of shorelines, wetlands, or gut are relatively flat with little erosion potential. Otherwise, they are designed with stabilized surfaces (aggregate, permeable pavers, or pavement) and/or drainage is diverted into a stormwater practice.
- Maintenance plans reflect a higher frequency of inspection and maintenance on steep roads or roads in sensitive areas.



Standard not applicable , explain why:

### UR-6. Reduced Surface Travel Time

Minimize the amount of time spent and distance traveled by runoff on the road surface.

- An adequate number of turnouts, check dams, and other drainage practices is provided based on road slope. *Describe segment length, slope, and # of practices:*

If the recommended spacing cannot be provided, describe alternatives used to mitigate drainage concerns.

- Ditches are designed to safely handle the 10-yr design storm and calculations are provided to confirm this standard is being met. *Where are these calculations provided?*

Standard not applicable , explain why:

### UR-7. Conveyances & Outlets

Ditches, culverts, and outlets need to be designed based on future drainage conditions to reduce the potential for backups and erosion.

- Designs meet Stormwater Standards ESC-8 and SW-5.
- Check the following strategies applied to meet this standard:
  - The size and condition of uphill and downhill conveyance structures was evaluated.
  - Drainage area delineations to each culvert (e.g., cross-drain, driveway, or culvert) are provided.
  - Drainage volume and flow rates take into account future conditions (build out, larger and more intense storms).

- No pipes are less than a minimum 18-inch diameter.
- Driveway culverts have proper headwall protection to prevent ditch erosion.
- Gut culverts are at least as wide as the existing channel bottom.
- If the standard cannot be met, all ditches are lined or have check dams and are designed for the 10-yr, 24-hr storm (using most updated precipitation frequencies).
- All outlets are properly stabilized and concentrated flows dissipated to prevent erosion.

Standard not applicable or cannot be met , *explain why:*

### UR-8. Surface Compaction

Be sure that proper compaction of road surface is provided during installation or regrading.

- The plan specifies that the road surface course must be compacted using a roller of 15 tons or higher (or equivalent).

Standard not applicable or cannot be met , *explain why:*

### UR-9. Stabilized Cut/Fill Slopes

Minimize erosion of side slopes.

- Documentation provided that shows standard ESC-5 is being met.
- Adequate temporary and permanent stabilization is being provided for cut and fill slopes. *Describe methods:*

Standard not applicable , *explain why:*

### UR-10. Maintenance Agreement

Improve maintenance effectiveness by assigning responsible parties and setting long-term expectations for maintenance costs and tasks.

- An approved long-term maintenance plan and signed maintenance agreement is provided (can be part of ESC-10 and SW-7 submittals).

# B

## APPENDIX B

### PRECIPITATION DATA

Much of the readily available precipitation analyses for the USVI have not been recently updated. The information presented here, while dated, was used to help generate the stormwater standards related to water quality, recharge, and flood control. This information is provided for reference purposes and is best suited for initial site planning. While this data can be used for stormwater system modeling, it is recommended that designers and engineers apply the adjusted NOAA Atlas 14 "plus" method described in Chapter 3 to calculate rainfall depths for design storms that reflect more recent periods of record and changing climate conditions.

## DATA SOURCES

Key websites where rainfall information can be obtained for the USVI include:

- Frequency analyses can be obtained from the NOAA Precipitation Frequency Data Server (PFDS) <https://hdsc.nws.noaa.gov/pfds/>
- Daily rainfall records can be downloaded from the NOAA National Centers for Environmental Information [www.ncei.noaa.gov/products/land-based-station/global-historical-climatology-network-daily](http://www.ncei.noaa.gov/products/land-based-station/global-historical-climatology-network-daily).
- Additional weather stations can also now be accessed through the CoCoRaHS website [www.cocorahs.org](http://www.cocorahs.org), but the period of record may be shorter.

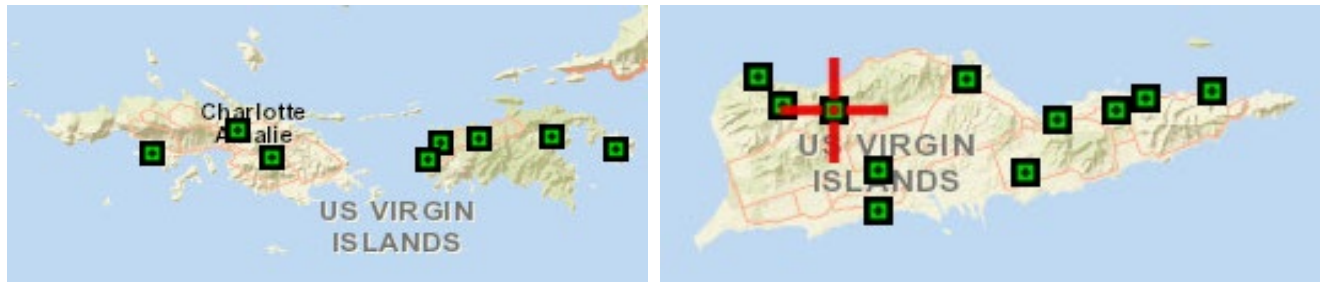

*Weather stations in the USVI available from the NOAA Precipitation Frequency Data Server.*

## ANNUAL RAINFALL

The two most recent mean annual precipitation maps for the Virgin Islands are from Oregon State University Climate Center (2004) and NOAA National Weather Service (2020 update).

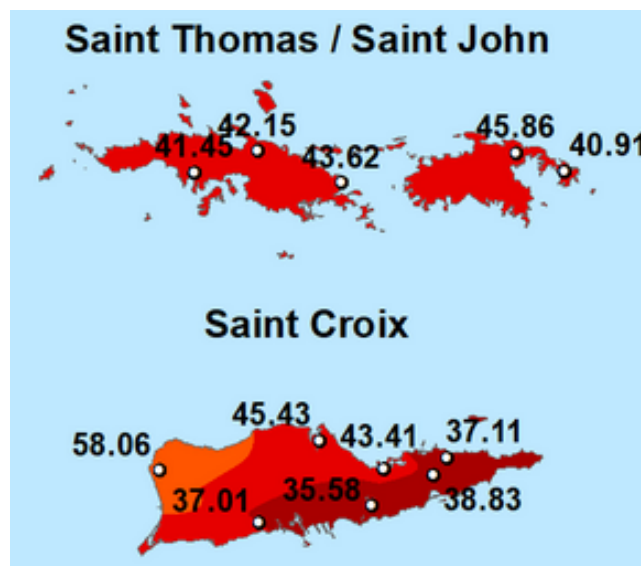

*USVI mean annual rainfall totals (in inches) 1981-2020 (NOAA NWS, 2020)*

Oregon State University Climate Center (2004) used partially gridded annual precipitation for the climatological period of 1971-2000. ([www.prism.oregonstate.edu/products/pacisl.phtml](http://www.prism.oregonstate.edu/products/pacisl.phtml)).

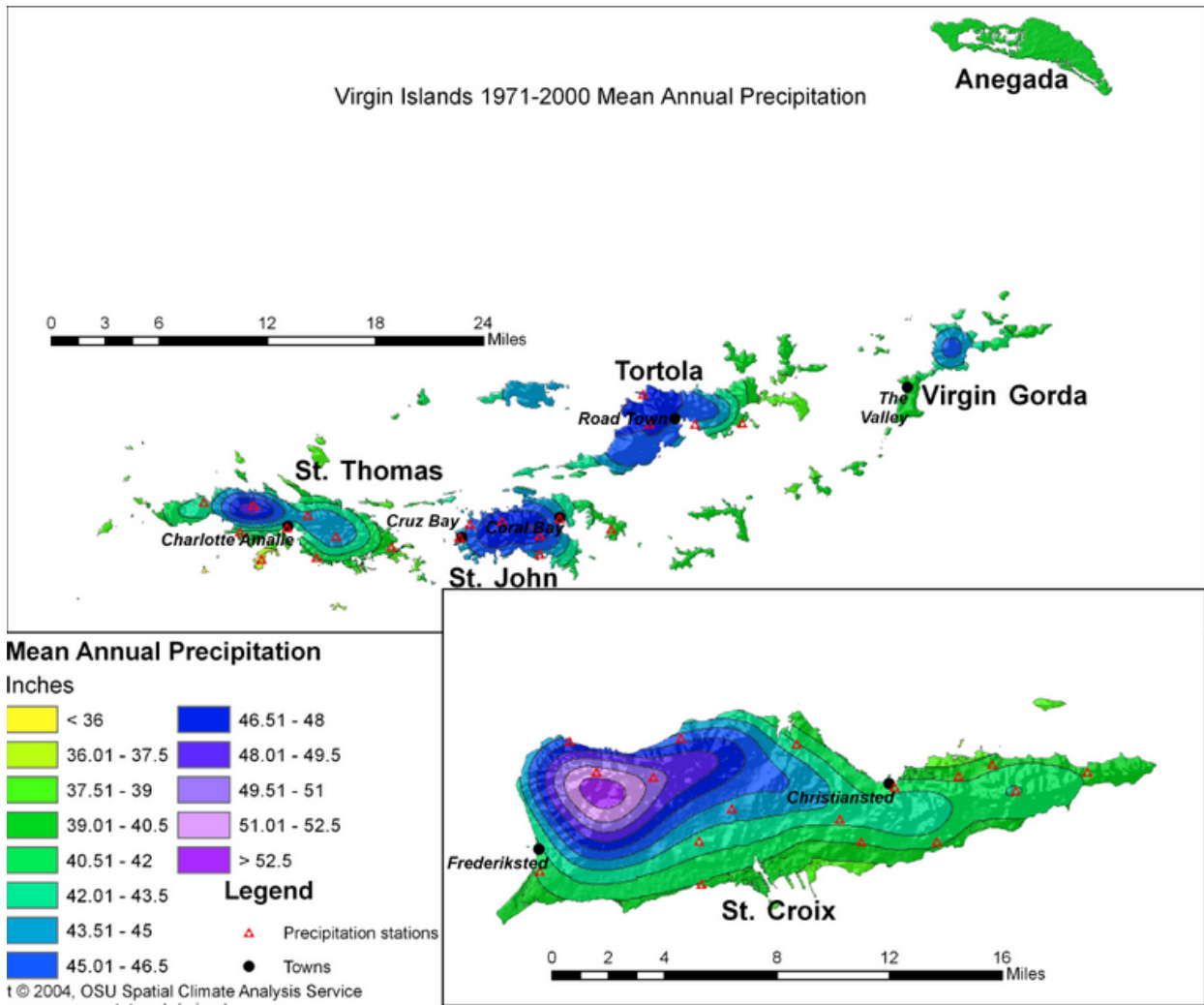

Copyright © 2011, PRISM Climate Group, Oregon State University, <http://prism.oregonstate.edu>

## RAINFALL FREQUENCY MAPS

The maps below are excerpts of average rainfall depth maps for 24-hr duration storms from the 2006 NOAA Atlas 14: US Precipitation Frequency Atlas, Vol. 3: Puerto Rico and the USVI, Ver. 3. The period of record on average is 54 years of daily records through 2004.

1-yr, 24-hr



2-yr, 24-hr

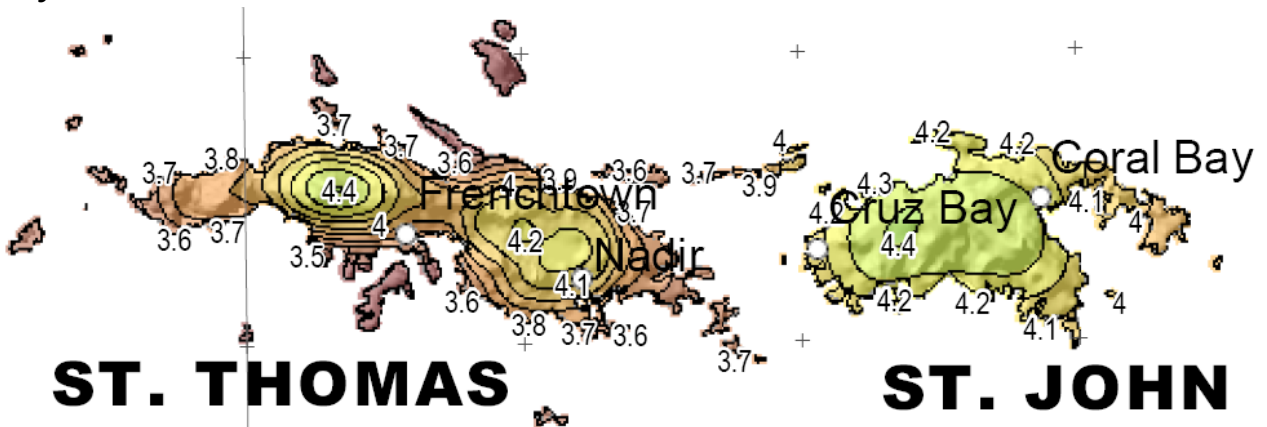

5-yr, 24-hr

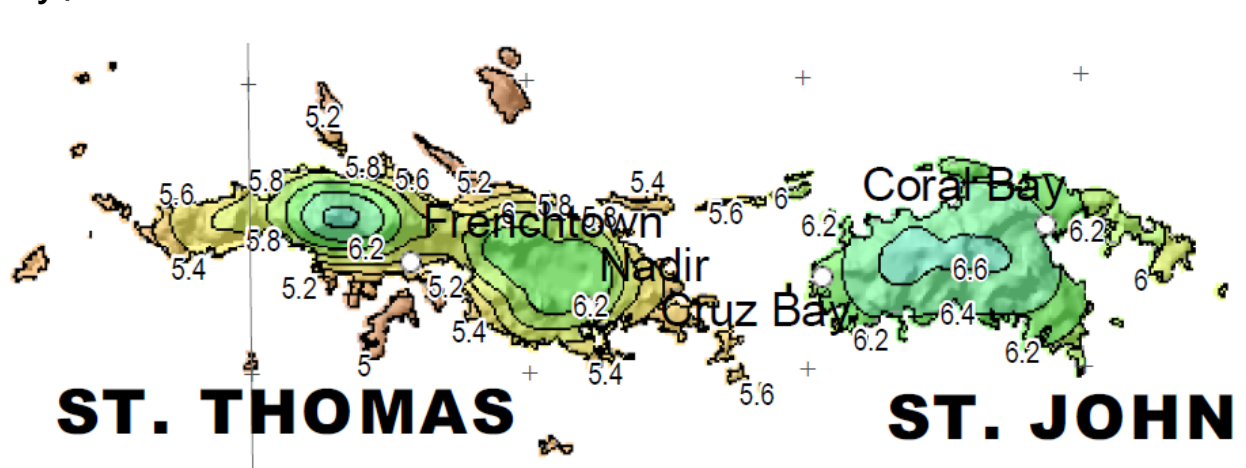

10-yr, 24-hr

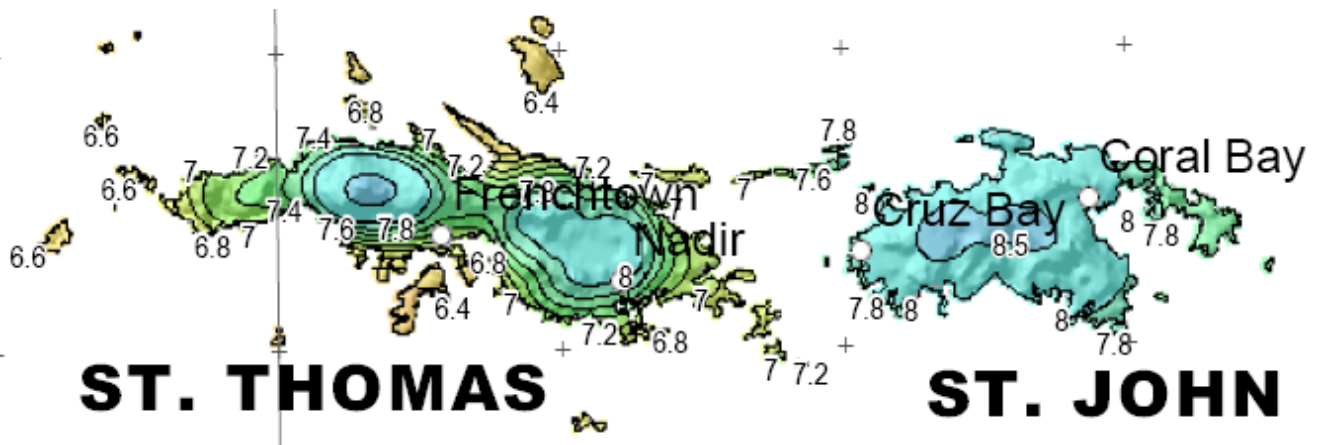

25-yr, 24-hr

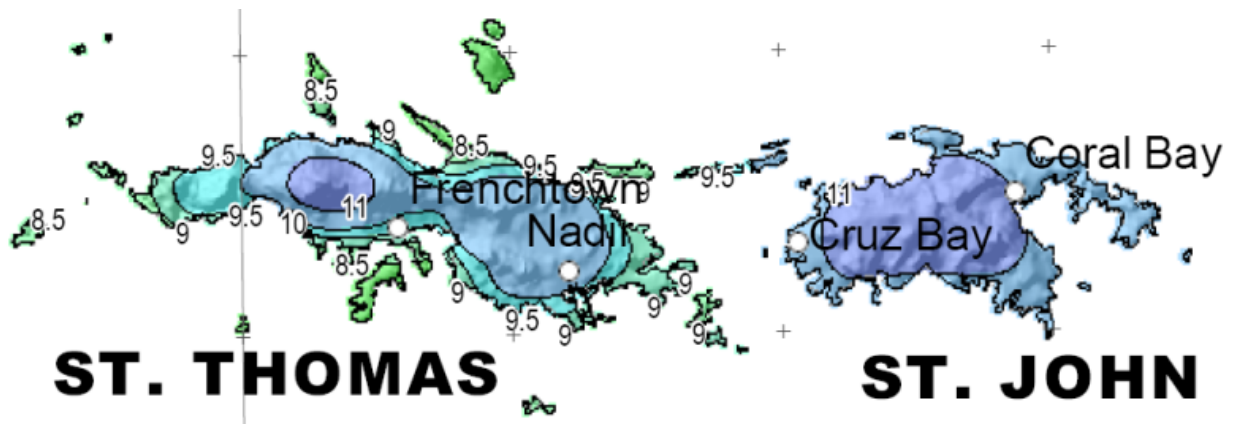

100-yr, 24-hr

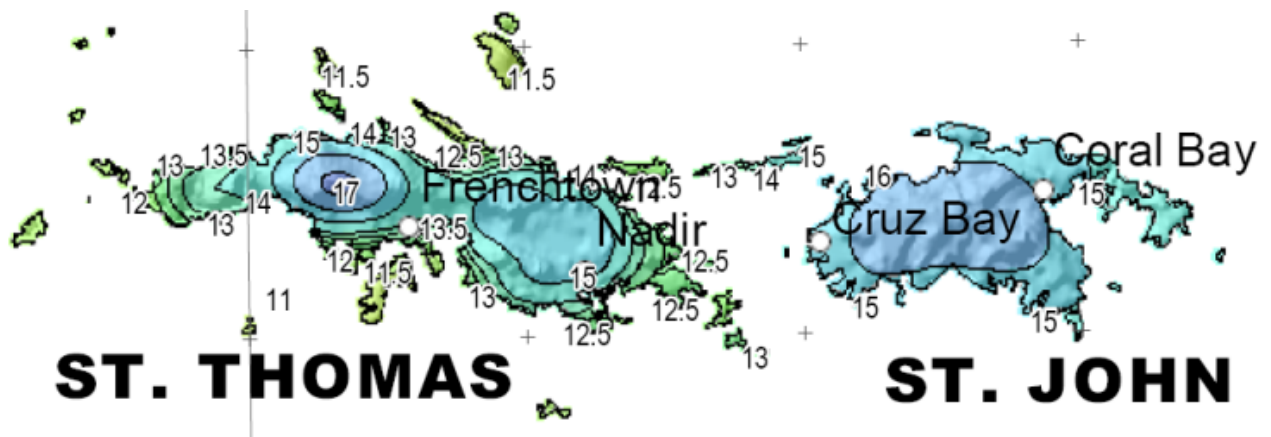

1-yr, 24-hr

# ST. CROIX ISLAND

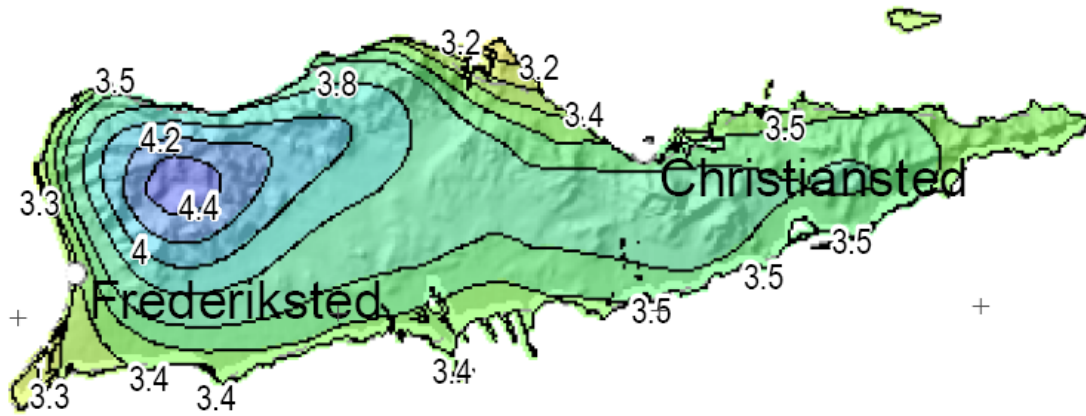

2-yr, 24-hr

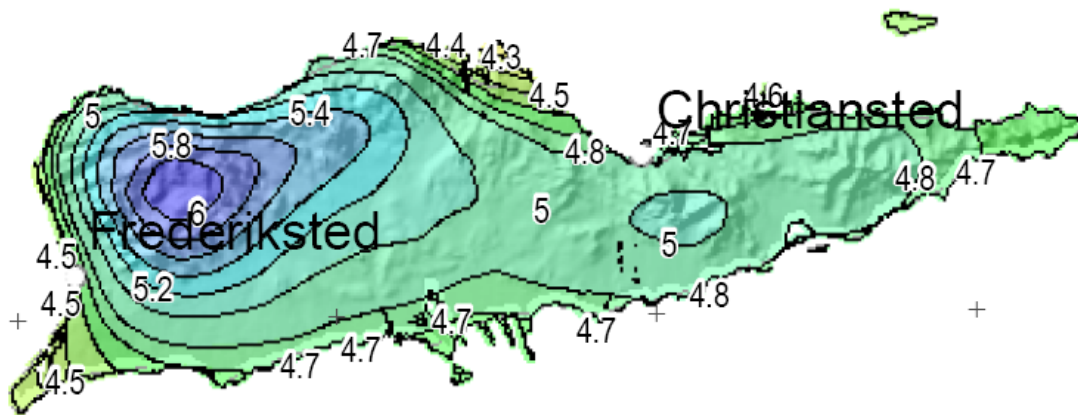

5-yr, 24-hr

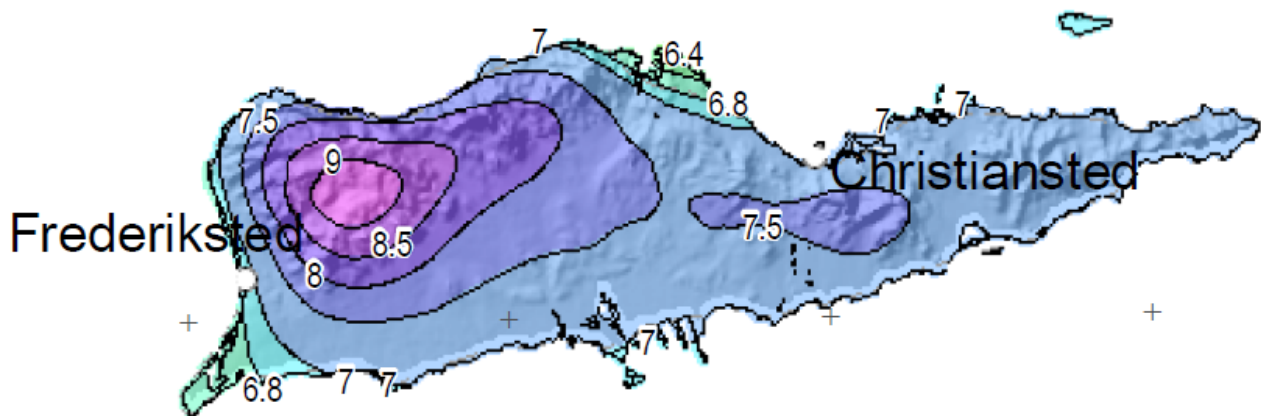



10-yr, 24-hr

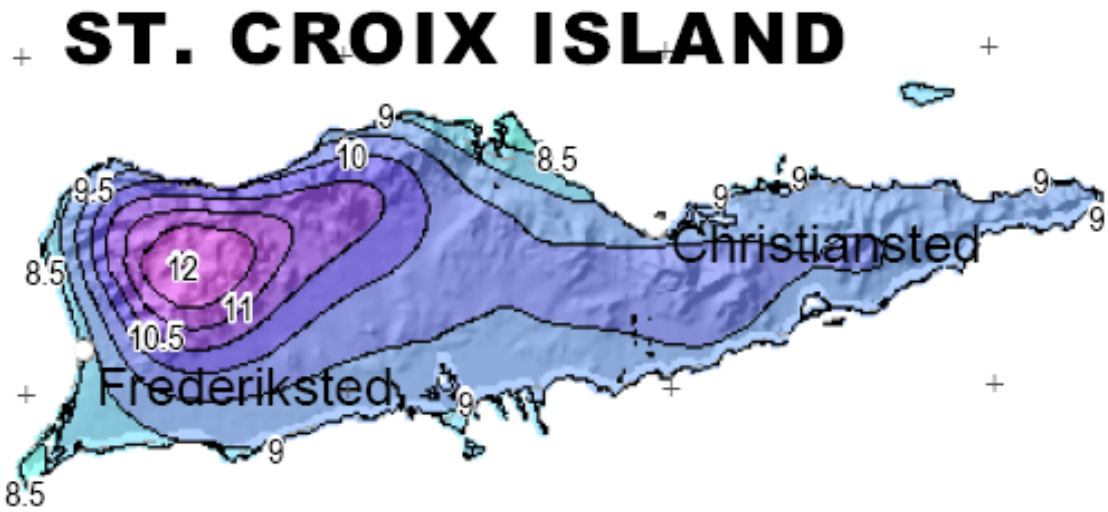

25-yr, 24-hr

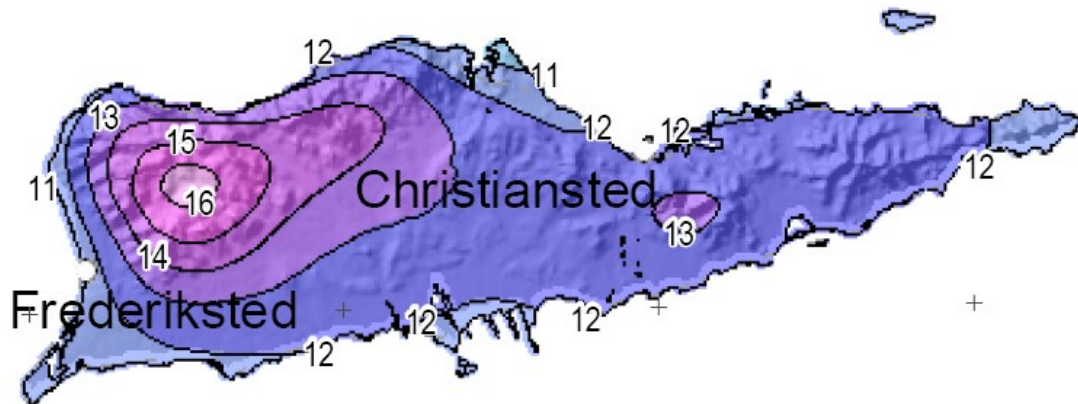

100-yr, 24-hr

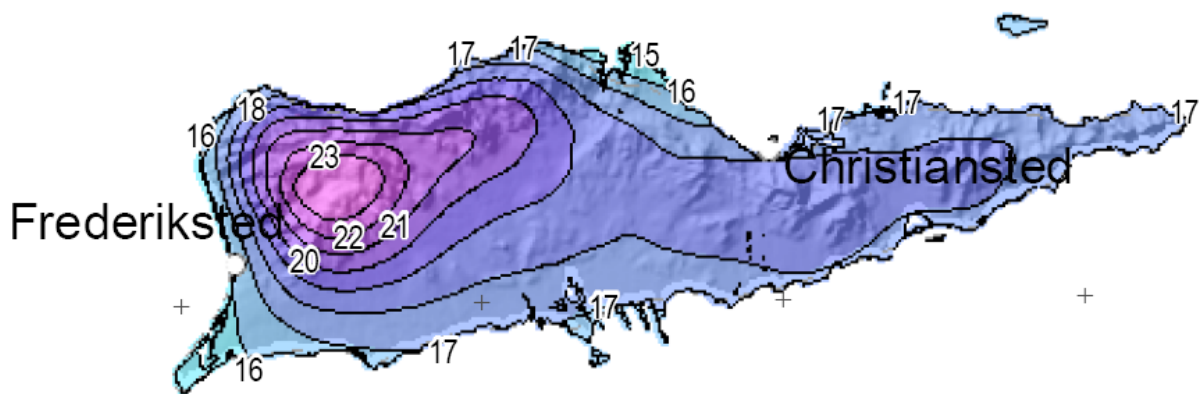

## PREVIOUS RAINFALL ANALYSES

In 2014, Horsley Witten updated the rainfall data presented in the 2002 Environmental Handbook, which was generated from a precipitation analysis done by NRCS (formerly USDA-SCS) in 1986. This updated analysis extended the period of record through 2014 and informed discussions with the Stormwater Working Group on:

1. The amount (depth and design storm) of rainfall for management and, ultimately, the size of the structural stormwater facilities needed to handle that volume;
2. Regional variations in rainfall to determine if a single standard can be applied across all three islands, or if localized criteria are more appropriate; and
3. Trends in precipitation frequency and intensity to better plan for climate change.

All data were obtained from the NOAA National Climatic Data Center archive (2014), a resource that has archived precipitation data for nearly 40 rain gauges throughout the USVI. However, only those gauges that spanned at least 30 years of records were included in this analysis. Pertinent characteristics for the twelve stations that met that requirement are summarized in Table B.1.

**Table B.1: Location and data record characteristics for USVI rain gauge stations used.**

Station Name	Station ID	Island	Elevation (ft)	Record Start Date	Record End Date	Record Length (years)	Missing Records
Christiansted Airport	670198	St. Croix	61	1951	2014	64	15%
Beth Upper New Works	670480	St. Croix	110	1972	2013	42	38%
Christiansted Fort	671740	St. Croix	30	1921	2013	93	64%
East Hill	672560	St. Croix	120	1972	2013	42	7%
Granard	673677	St. Croix	65	1972	2003	32	5%
Monpellier	674900	St. Croix	200	1979	2013	35	16%
Coral Bay	671790	St. John	30	1972	2011	40	19%
Cruz Bay	671980	St. John	8	1972	2013	42	30%
East End	672551	St. John	105	1972	2013	42	20%
Redhook Bay	677600	St. Thomas	2	1980	2013	34	52%
Charlotte Amalie Airport	678905	St. Thomas	20	1953	2014	62	22%
Wintberg	679450	St. Thomas	645	1972	2010	39	8%

The RFS analysis involves sorting all daily precipitation data in a spreadsheet from largest to smallest and eliminating all daily records with 0.1 inch of rainfall or less (it is assumed these small rain events will be captured in surface depressions or vegetation and not produce runoff). The resulting values were then ranked, with the largest rainfall depth receiving the rank of 1. The non-exceedance probability was then calculated for each record to determine the 90<sup>th</sup> and 95<sup>th</sup> percentile rainfall depths.

Figure B.1 shows an example RFS graph for the USVI. In this case, the 90<sup>th</sup> percentile event is estimated around 0.96 inches, and the 95<sup>th</sup> percentile event is estimated at 1.46 inches.

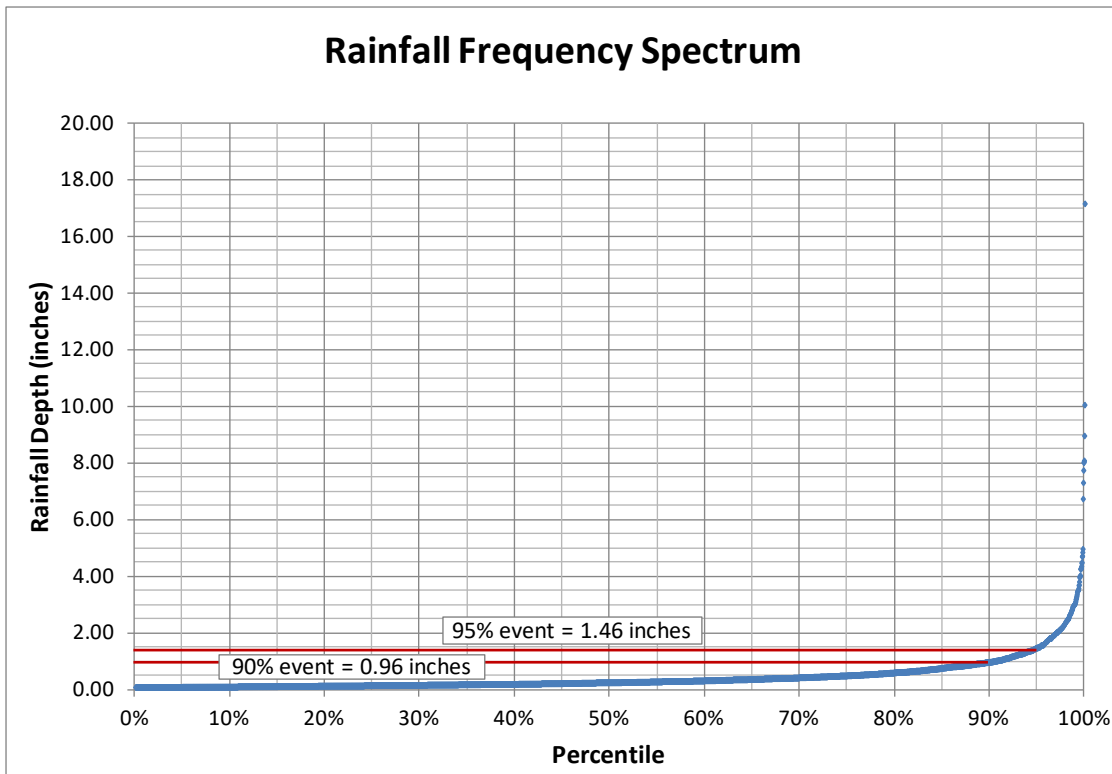

**Figure B.1: Example Rainfall Frequency Spectrum graph for Station 670198 (St. Croix).**

Table B.3 summarizes the RFS analysis results for each of the twelve rain gauge stations, including the 90<sup>th</sup> and 95<sup>th</sup> percentile storm depths.

**Table B.3: Estimated storm depth statistics by rain gauge station.**

Station Name	Station ID	Island	90th % (inch)	95th % (inch)
Christiansted Airport	670198	St. Croix	0.96	1.46
Beth Upper New Works	670480	St. Croix	1.04	1.82
Christiansted Fort	671740	St. Croix	1.00	1.51
East Hill	672560	St. Croix	1.03	1.60
Granard	673677	St. Croix	0.95	1.46
Monpellier	674900	St. Croix	1.13	1.76
<b>Average for St. Croix</b>			<b>1.02</b>	<b>1.60</b>
Coral Bay	671790	St. John	1.02	1.62
Cruz Bay	671980	St. John	1.06	1.55
East End	672551	St. John	0.94	1.40
<b>Average for St. John</b>			<b>1.01</b>	<b>1.53</b>
Redhook Bay	677600	St. Thomas	1.16	1.66
Charlotte Amalie Airport	678905	St. Thomas	1.01	1.49
Wintberg	679450	St. Thomas	1.07	1.62
<b>Average for St. Thomas</b>			<b>1.08</b>	<b>1.59</b>
<b>Average for USVI</b>			<b>1.03</b>	<b>1.57</b>

In addition, precipitation frequency estimates for the various rain gauge locations were obtained from the NOAA Precipitation Frequency Data Server (PFDS) Atlas 14 (2014). 24-hour duration storm depth magnitudes (in inches) are displayed in Table 4 for various return intervals. An example precipitation frequency cartographic map is provided in Figure 3; these are available for all islands and all listed return intervals.

**Table B.4: Precipitation frequency estimates by rain gauge station (NOAA PFDS, 2014).**

Station Name	Station ID	Island	Magnitudes (in.) of 24-hour Duration Storms for Different Return Intervals						
			1 Year	2 Years	5 Years	10 Years	25 Years	50 Years	100 Years
Christiansted Airport	670198	St. Croix	3.48	4.73	7.11	9.13	12.1	14.7	17.4
Beth Upper New Works	670480	St. Croix	3.67	5.00	7.52	9.66	12.8	15.5	18.5
Christiansted Fort	671740	St. Croix	3.58	4.88	7.34	9.44	12.6	15.2	18.1
East Hill	672560	St. Croix	3.51	4.79	7.20	9.25	12.3	14.9	17.7
Granard	673677	St. Croix	3.60	4.90	7.37	9.48	12.6	15.2	18.1
Monpellier	674900	St. Croix	3.37	4.59	6.90	8.85	11.7	14.2	16.9
<b>Average for St. Croix</b>			<b>3.54</b>	<b>4.82</b>	<b>7.24</b>	<b>9.30</b>	<b>12.35</b>	<b>14.95</b>	<b>17.78</b>
Coral Bay	671790	St. John	3.15	4.29	6.45	8.30	11.0	13.4	15.9
Cruz Bay	671980	St. John	3.05	4.15	6.25	8.03	10.7	12.9	15.4
East End	672551	St. John	2.92	3.99	5.99	7.70	10.2	12.4	14.7
<b>Average for St. John</b>			<b>3.04</b>	<b>4.14</b>	<b>6.23</b>	<b>8.01</b>	<b>10.63</b>	<b>12.90</b>	<b>15.33</b>
Redhook Bay	677600	St. Thomas	NA	NA	NA	NA	NA	NA	NA
Charlotte Amalie Airport	678905	St. Thomas	2.69	3.65	5.50	7.04	9.3	11.3	13.4
Wintberg	679450	St. Thomas	2.97	4.06	6.09	7.83	10.4	12.6	15.0
Estate Fort Mylnar*	672823	St. Thomas	3.10	4.22	6.35	8.16	10.9	13.1	15.6
<b>Average for St. Thomas</b>			<b>2.92</b>	<b>3.98</b>	<b>5.98</b>	<b>7.68</b>	<b>10.21</b>	<b>12.33</b>	<b>14.67</b>
<b>Average for USVI</b>			<b>3.17</b>	<b>4.31</b>	<b>6.48</b>	<b>8.33</b>	<b>11.06</b>	<b>13.39</b>	<b>15.93</b>

\*Note: Precipitation frequency estimates for Redhook Bay (Station 677600) were “Not Available” from the NOAA Atlas 14 resource. In response, the Estate Fort Mylnar station (672823) was added to better represent regional rainfall patterns on St. Thomas.

From this analysis, the following conclusions were drawn:

Water Quality - Based on the small storm data provided in Table 2, the 90<sup>th</sup> and 95<sup>th</sup> percentile storms do not vary significantly by location. Using 1 inch (or 1.6 inches) throughout the USVI as a water quality standard seems appropriate; the slight variation across the three islands does not warrant creating a complicated standard.

Water Quantity – The results in Table 4 do vary significantly by location. We recommend using the NOAA maps for key design storms; designers can locate their projects on the maps to determine the applicable rainfall depths.

Previous to HW’s updated analysis, Cadmus (2011) developed precipitation frequency estimates for 14-digit HUC watersheds in the USVI using the NOAA PFDS through 2008 and processed using ArcGIS to derive watershed scale precipitation frequency estimates. Magnitudes for storms of 24-hour duration for typical return intervals were estimated for each 14-digit HUC. In general, St. Croix receives the largest amount of rainfall, while St. Thomas receives the smallest. Rainfall variability is highest for St. Croix watersheds.

**Table B.5: Data record characteristics for USVI rain gauge stations used by Cadmus in 2011.**

Station Name & ID	Island	Record Start Date	Record End Date	% Missing Records	90 <sup>th</sup> Percentile Storm Depth (inches)	95 <sup>th</sup> Percentile Storm Depth (inches)	Mean Storm Depth (inches)
Christiansted Airport (670198)	St. Croix	1981	2008	4	0.9	1.4	0.5
Christiansted Fort (671740)	St. Croix	1972	2008	32	1.0	1.5	0.5
East Hill (672560)	St. Croix	1972	2008	5	1.0	1.6	0.5
Montpellier (674900)	St. Croix	1979	2008	10	1.1	1.6	0.5
Coral Bay (671790)	St. John	1972	2008	20	0.9	1.4	0.5
Cruz Bay (671980)	St. John	1972	2008	14	1.1	1.7	0.5
East End (672551)	St. John	1972	2008	17	1.2	1.9	0.5
Redhook Bay (677600)	St. Thomas	1980	2008	37	1.3	2.0	0.6
Charlotte Amalie Airport (678905)	St. Thomas	1972	2010	14	1.0	1.5	0.5
Wintberg (679450)	St. Thomas	1972	2008	8	1.1	1.6	0.5

**Table B.6: Estimated storm depth statistics by rain gauge station calculated by Cadmus in 2011.**

HUC	Magnitudes (inches) of 24-hour Duration Storms for Different Return Intervals						
	1 Year	2 Years	5 Years	10 Years	25 Years	50 Years	100 Years
Northeast St. Croix (21020002010030)	3.5	4.8	7.3	9.3	12.4	15.0	17.8
Southeast St. Croix (21020002020010)	3.6	4.9	7.3	9.4	12.6	15.2	18.1
Northcentral St. Croix (21020002010020)	3.7	5.0	7.5	9.7	12.9	15.6	18.6
Airport St. Croix (21020002020030)	3.8	5.2	7.9	10.2	13.5	16.4	19.6
Southwest St. Croix (21020002020040)	3.7	5.0	7.6	9.7	12.9	15.7	18.6
Northwest St. Croix (21020002010010)	3.9	5.3	8.0	10.3	13.7	16.6	19.8
Southparts St. Croix (21020002020020)	3.6	4.9	7.4	9.5	12.6	15.2	18.1
North St. John (21020001020010)	3.1	4.3	6.4	8.2	10.9	13.3	15.8
Southeast St. John (21020001020020)	3.1	4.2	6.4	8.2	10.9	13.2	15.7
Southwest St. John (21020001020030)	3.2	4.3	6.5	8.4	11.2	13.6	16.1
Southwest St. Thomas (21020001010040)	2.9	3.9	5.8	7.5	9.9	12.0	14.2
Southeast St. Thomas (21020001010030)	3.0	4.0	6.1	7.8	10.3	12.5	14.8
Northeast St. Thomas (21020001010020)	2.9	3.9	5.8	7.5	9.8	11.8	13.9
Northwest St. Thomas (21020001010010)	2.9	4.0	6.0	7.7	10.2	12.4	14.7

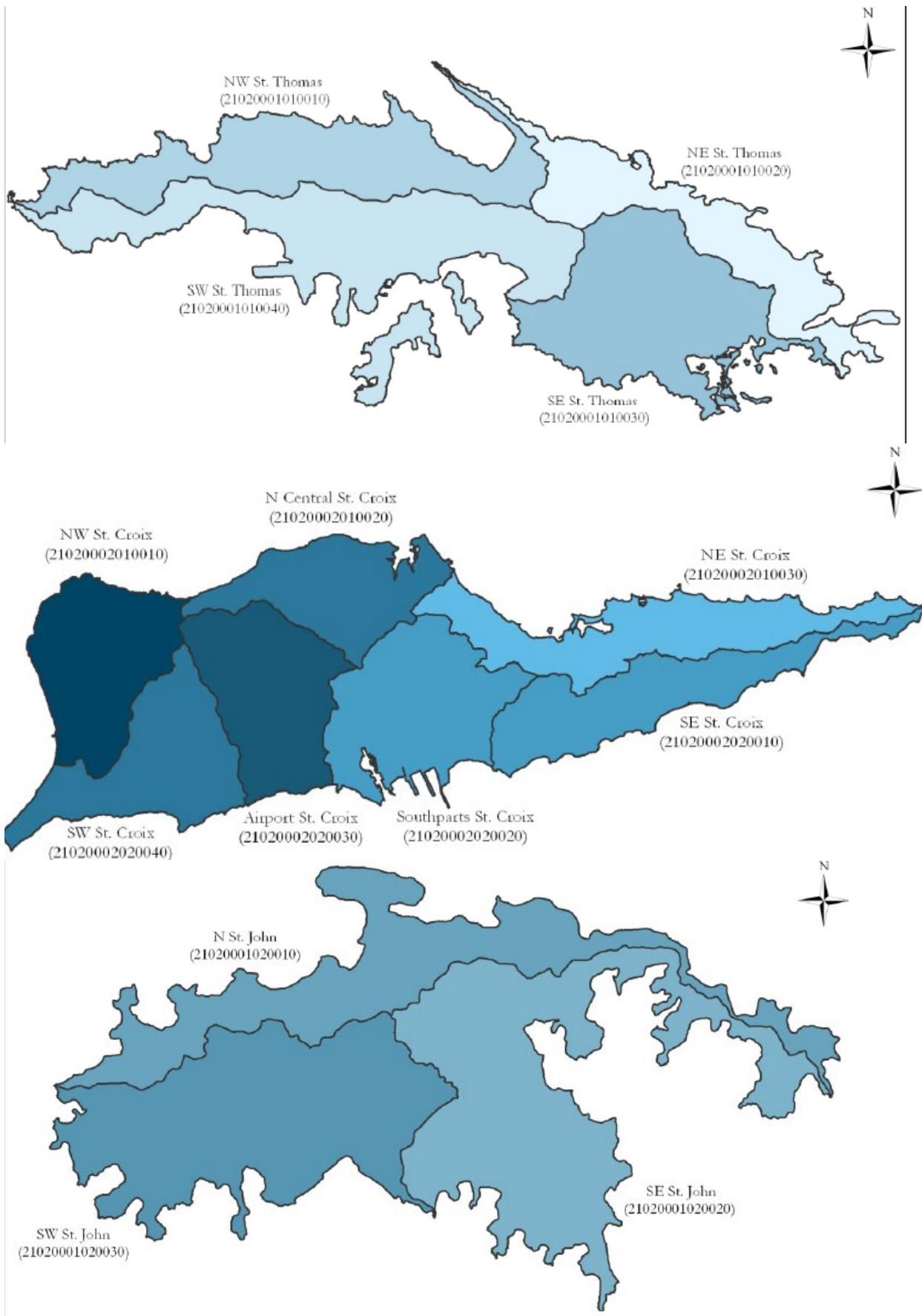



# APPENDIX C

## SAMPLE OPERATIONS AND MAINTENANCE PLAN

This appendix includes a sample plan for operations and maintenance and a maintenance agreement template for a post-construction stormwater management facility.

The O&M plan provided here is merely an example of a post-construction stormwater operations and maintenance plan. It is intended to demonstrate the type of information to be included and to encourage designers to think about the information future operators will need to understand where the facilities are, how they work, and how to keep them functioning properly. This example plan is derived from a retrofit project at a boat ramp on Cape Cod, MA, so the landscape and snow removal elements, of course, will not be relevant to the VI. Your plan should be adapted to the practices, plants, and procedures specific to your proposed management system.

The key aspects of the example maintenance agreement are the clear delineation of responsibilities, such as:

- Identification of who will perform the inspections and how often.
- Listed duties (e.g., bushwacking, debris removal, replanting)
- Defined roles for the responsible authority, such as inspection, and/or modifications to the system such as resizing an orifice.
- The course of action to be taken if the owner does not fulfill their obligations.
- Requirement of a report, possibly annually, that would serve to keep the owner involved and aware of their responsibilities.

**SAMPLE**  
**OPERATION AND MAINTENANCE PLAN**  
**SITE NAME STORMWATER RETROFIT**  
*ADDRESS*



Prepared for:

**AGENCY NAME**

**ADDRESS**

Prepared by:

**ORGANIZATION**  
**DATE**



**Operations & Maintenance Plan**  
**Green Stormwater Infrastructure**  
**SITE NAME**

---

**TABLE OF CONTENTS**

	<b>Page</b>	
<b>1.0</b>	<b>INTRODUCTION</b>	<b>2</b>
<b>2.0</b>	<b>RESPONSIBLE PARTIES</b>	<b>2</b>
<b>3.0</b>	<b>GREEN STORMWATER INFRASTRUCTURE</b>	<b>3</b>
<b>3.1</b>	How Does Green Infrastructure Work?	3
<b>3.2</b>	What is Required for Maintenance?	3
<b>3.3</b>	Sand Filters	3
<b>3.4</b>	Structural Components	4
	Structural Components: Maintenance Schedule	6
<b>3.5</b>	Plantings	7
	Plantings: Maintenance Schedule	12
	Weed Identification	13
<b>4.0</b>	<b>GENERAL SITE MAINTENANCE</b>	<b>16</b>
<b>5.0</b>	<b>LONG-TERM POLLUTION PREVENTION PLAN</b>	<b>17</b>

**APPENDICES**

- A.** Sand Filter Area Inspection Report
- B.** Plantings Maintenance Checklist
- C.** Planting Plans

## 1.0 INTRODUCTION

---

This document provides a general description along with the operation and maintenance requirements for the **SITE NAME** Stormwater Retrofit project at **ADDRESS**. The responsible parties are required to inspect and maintain all measures as outlined in this maintenance guide throughout the year. Site maintenance is divided into three categories as outlined below.

1. Green Stormwater Infrastructure
  - Structural Components
  - Structural Maintenance Schedule
  - Planting
  - Plantings Maintenance Schedule
  - Weed Guide
  
2. General Site Maintenance
  - Trash & Debris
  - Pet Waste
  - Pavement Sweeping
  - Contributing Drainage Areas
  - Snow Removal
  - De-icing
  
3. Long-Term Pollution Prevention Measures

## 2.0 RESPONSIBLE PARTIES

---

Representative: XX XXXXXX, P.E.  
Title: Town Engineer  
**AGENCY**  
**ADDRESS**  
Email: **EMAIL ADDRESS**  
Ph: **PHONE**

*\*It's important to note that while the sediment forebay for this retrofit is on Town-owned property, the sand filter was constructed on **OWNER'S** land for which **ORGANIZATION NAME** holds the conservation restriction. However, the Town has a maintenance agreement with the **OWNER** and is responsible for maintenance of the entire system.*

## 3.0 GREEN STORMWATER INFRASTRUCTURE

---

### 3.1 How Does Green Infrastructure Work?

Green Stormwater Infrastructure (GSI) is a nature-based approach to stormwater treatment and management. These stormwater practices or “treatment areas” are designed to mimic nature and use the natural filtration properties of soil and plants to remove pollutants from stormwater runoff prior to discharging to the municipal drainage system or receiving waters.

GSI relies on the following basic steps to function properly. Structural components of the practices facilitate the functioning of the steps. If one of these steps, or components, does not work properly, the entire system can be compromised and the GSI practice itself could be contributing to maintenance problems. This can lead to a landscape nuisances, more frequent maintenance and costly repairs/improvement.

1. **Collect** (Inlets)
2. **Move Water** (Conveyance) if needed, can come after capturing sediment
3. **Capture Sediment** (Pretreatment)
4. **Treat and Manage** (Filter, Infiltrate or Store)
5. **Overflow** (Structures and Spillways)

### 3.2 What is required for Maintenance?

As these are nature-based systems that often rely on plant upkeep, the maintenance for GSI typically falls under landscape and general site maintenance services. Proper operation and maintenance (O&M) are vital to its long-term viability. Regularly scheduled maintenance can prevent system failures due to sediment build-up, damage, or deterioration. The maintenance requirements, outlined in this guide, are critical to ensure proper treatment, maintain storage capacity and preserve the visual integrity.

### 3.3 Sand Filters

Sand filters are a type of GSI that has a proven track record of better pollutant removal capabilities than more conventional drainage systems. Sand filters use a sand media and vegetation to remove nitrogen and bacteria, and reduce stormwater runoff.

The maintenance for the sand filter is divided into two categories:

- a. The **Structural Components** that make up the basic steps of a functioning system
- b. **Plantings**, the landscape and filtration element

## STRUCTURAL COMPONENTS: SAND FILTER



### 3.4 Structural Components

1. **Collect:** Stormwater is captured in a slight depression (inlet) made of drivable pavers along the edge of the parking lot.
2. **Capture Sediment:** Sand and debris settle out within the permeable paver sediment forebay.
3. **Move Water:** Stormwater exits the forebay flowing over a weir structure and stone splash pad to the sand filter area.
4. **Treat and Manage:** Sand filter area media and vegetation remove nitrogen and bacteria and allow treated stormwater to infiltrate into the soil below; when the groundwater table is high, treated stormwater is conveyed to the outlet structure via a perforated underdrain with a cleanout near the split rail fence.
5. **Overflow:**
  - a. **Outlet Structure:** Runoff volume that exceeds the design storm (1") flows into the domed outlet structure and out to the wetland via a PVC pipe.
  - b. **Level Spreader/Overflow Spillway:** Runoff from extreme storms will flow over the level spreader to the wetland via a reinforced turf overflow spillway.



# STRUCTURAL COMPONENTS: SAND FILTER

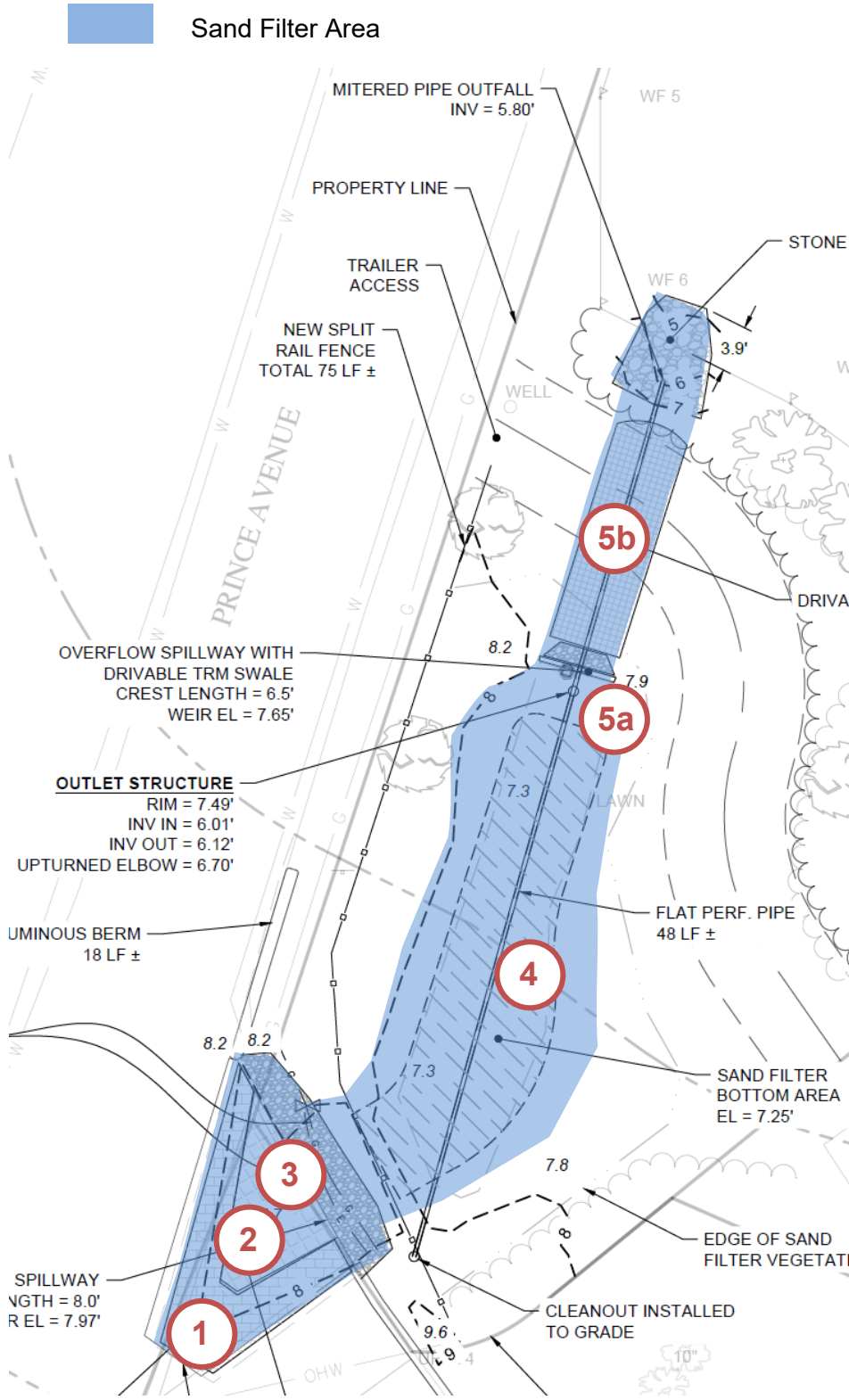

## STRUCTURAL COMPONENTS MAINTENANCE SCHEDULE: SAND FILTER

A site inspection of the sand filter components shall be conducted at least twice a year in the Spring and Fall, and after major storm events (2" of rain or greater). Debris and trash should be removed monthly and sediment removal should occur during the two site inspections and during the monthly debris and trash inspections as needed. See the calendar below and the Inspection Report in [Appendix A](#) for more information.

Sand Filter General Maintenance Schedule												
	Jan	Feb	Mar	Apr	May	Jun	July	Aug	Sep	Oct	Nov	Dec
Task	Frequency & Time of the Year											
Site Inspection				X					X			
Debris & Trash Removal				X	X	X	X	X	X	X	X	
Sediment Removal				X	x	x	x	x	x	X		

- should **also** be completed after major storm events
- X** required inspection
- x as needed

- When removing trash and debris during monthly inspections look for:
  - If sediment is > 3" in paver lined sediment forebay. Ensure sediment does not cause blockage of inlet weir. If it is, remove sediment.
  - If standing water does not drain after 48 hours. See Inspection report for action items.



*Use a shovel to sediment and debris from the forebay.*

- After rain event look for:
  - If standing water does not drain after 48 hours. See Inspection Report for action items.

See section below for information on plantings maintenance of the sand filter area. Use the plantings maintenance calendar to combine maintenance efforts.

# PLANTINGS

## 3.5 Plantings

The planting design for the sand filter consists of three landscape maintenance areas:

- Mowed Lawn Areas
- Low to No "Mow" Areas
- Natural Buffers

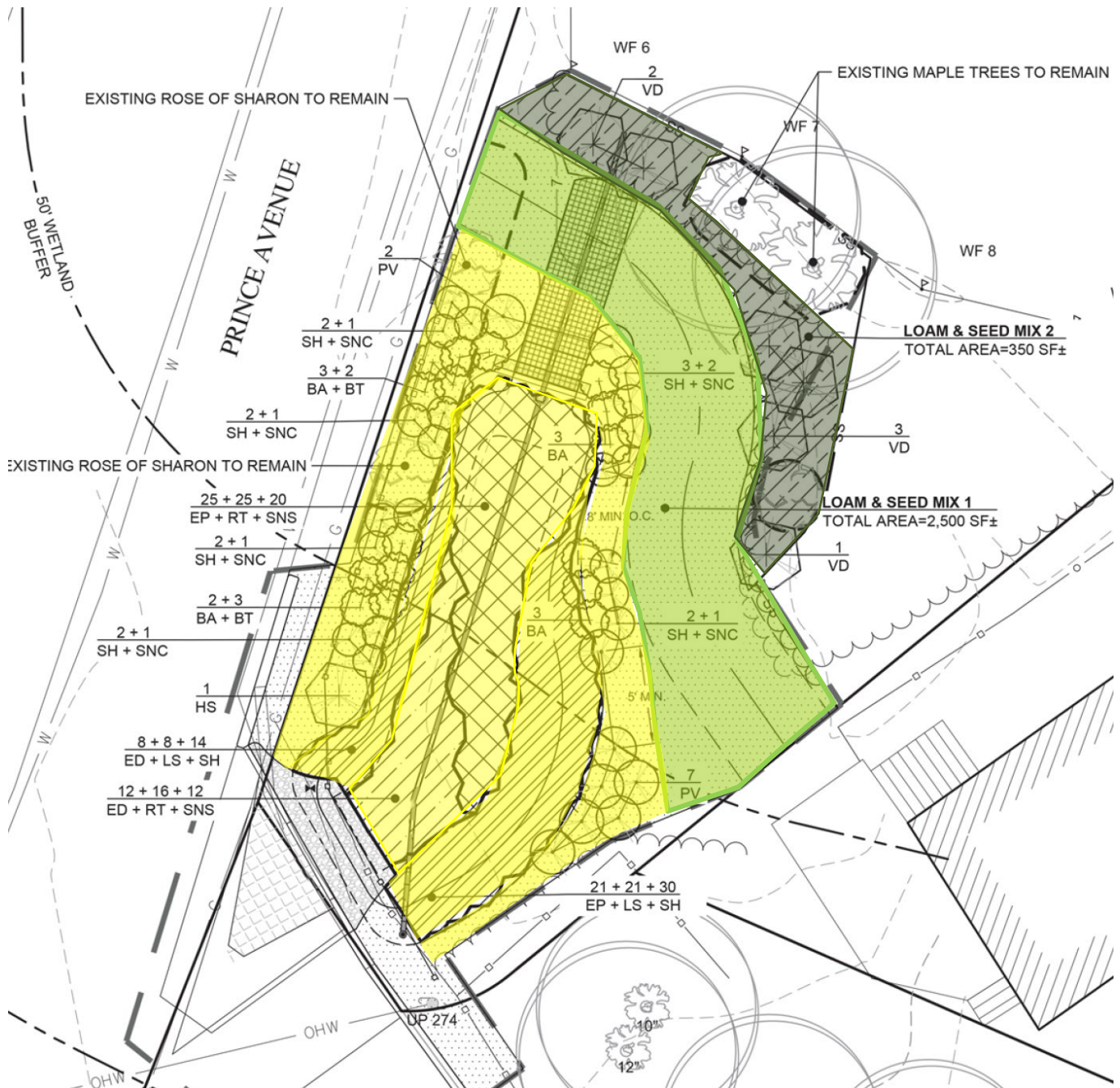

## PLANTINGS: MOWED LAWN AREAS MAINTENANCE

There is an area of the site that is allowed to be maintained as mowed lawn as necessary. Landscape maintenance of mowed lawn areas includes the following:

### Seeding

Loam and reseed bare spots with the specified seed mix as shown on the Planting Plan (see [Appendix C](#)).

### Mowing

Mowing can be done as frequently as once a week with a mulching mower or every other week during summer months; however, it can also be mown or weed whacked as infrequently as twice a growing season. If grass is only cut a few times a growing season or if there are mounds of clippings after mowing, bag the clippings and dispose of properly off-site - DO NOT dump on site. Maintain a cutting height of 3" or greater. Leave the grass taller during hot, summer months, and cut shorter during cooler periods of the growing season. Trim edges when necessary. Be careful mowing over the turf reinforcement matting across the overflow spillway area as shown above on the structural components plan; if any matting is visible and/or sticking up above the grass, re-loam and re-seed per seed mix on the planting plan (see [Appendix C](#)) on top of the matting to prevent it getting caught in equipment or impacting wildlife.

### Watering

Allowing the mowed lawn areas to "brown" is desired. Water only during drought conditions or during reseeding establishment period.

### Fertilizing

No fertilizer shall be used.

### Weeding

Weeding should be limited to invasive and weedy species (see Weed Identification below and the Weed Guide at <https://web.uri.edu/riss/files/In-the-Weeds.pdf>). Non-chemical methods (hand pulling and hoeing) are required; chemical herbicides are not allowed. Properly remove and dispose of all invasive species off site as to prevent colonization elsewhere, this includes disposal on land beyond the project area.



### Debris & Trash

Remove and properly dispose litter from all lawn areas prior to mowing.



## PLANTINGS: LOW/ “NO MOW” AREAS MAINTENANCE (SAND FILTER)

By design, plants in sand filter areas are meant to flourish throughout the growing season leaving dry standing stalks during the dormant months. Plants do not require fertilizers and/or watering. This area is designated as Low to No “Mow” - frequent mowing would eliminate selected meadow species, may promote the growth of undesirable plants, and require additional maintenance and watering. It is recommended this area be weed whacked no more than one time per year. Remove and replace vegetation as necessary, using the appropriate species as discussed on the next page. The best time to plant is in early to mid-fall or early to mid-spring. Specific maintenance activities of low to no “mow” areas include the following:

### Seeding

Loam and reseed bare spots with the specified seed mix as shown on the Planting Plan.

### Cutting Back

Recommend cutting with shears a maximum of once a year in early spring. Otherwise, allow areas to grow up to their natural heights (12”-36”) as to maintain a meadow appearance. Do NOT cut area lower than 6” – maintain sporadic wooden stakes on site at 6” height to provide visual cues during cutting. Depending on height of grasses and the time of year, grass cuttings/stalks may need to be raked and removed from site so as not to clog the sand filter. Use a leaf blower as needed to assist in clean-up.

### Pruning

Prune trees and shrubs to remove deadwood and low hanging branches.

### Watering

Water only during drought conditions or during the plant establishment period.

### Fertilizing

No fertilizer shall be used.

### Weeding

Weeding should be limited to invasive and weedy species (see section 3.6 Weed Identification below and the Weed Guide at <https://web.uri.edu/riss/files/In-the-Weeds.pdf>). Non-chemical methods (hand pulling and hoeing) are required; chemical herbicides are not allowed. Properly remove and dispose of off-site all invasive species to prevent colonization elsewhere; this includes disposal on land beyond the project area.

### Monitoring

During the establishment period, walk the low to no “mow” areas monthly without the intent to cut, but to look for invasive species, bare spots and identify potential pest or disease problems.

## PLANTINGS: NATURAL BUFFER AREAS MAINTENANCE

This area is intended to increase the natural buffer to the adjacent wetland and is not to be disturbed. Maintenance of natural buffer areas includes the following:

### Monitoring

Walk the buffers to look for potential invasive species and identify potential disease.

### Weeding

Weeding should be limited to invasive and weedy species (see section 3.6 Weed Identification below and the Weed Guide at <https://web.uri.edu/riss/files/In-the-Weeds.pdf>). Non-chemical methods (hand pulling and hoeing) are required; chemical herbicides should be avoided. Properly remove and dispose of all invasive species as to prevent colonization elsewhere; this includes disposal on land beyond the project area.

### Watering

Water only during drought conditions or during the plant establishment period.

### Debris & Trash

Remove and properly dispose litter from all natural areas.



## PLANTINGS: REPLACEMENTS

The plants that thrive in sand filter areas are typically quite drought tolerant due to the filter profile having a top layer of planting soil and sand below. They need to be able to withstand periods of inundation after storm events; however, when it doesn't rain, there will be less water held naturally in the sand than in other soil types for the plants to use, and so the plants need to be drought tolerant as well.

Specifying plants native to the area increases the ecosystem benefits by helping to support native wildlife like pollinators.

If replacements are needed, use the planting plan as a guide (see [Appendix C](#)). However, if all the plants of a certain species have not done well in the sand filter, do not replace with that same species. Rather, replant with one or more of the other species that has thrived under the sand filter conditions or have a plant professional choose a different species based on current photos of the site and the following site-specific considerations.

Plants for this sand filter should be:

- Preferably native
- Drought tolerant
- Tolerant of inundation for 24 hours
- Size constraints:
  - taller perennials/grasses at the bottom of the sand filter
  - shorter perennials/grasses on the side slopes
  - screening plants along the top of slope along Prince Avenue
- Sun and salt tolerant
- A mix of different types of plants that will create a resilient plant community: cold & warm season grasses, perennials, groundcovers in all areas.



## PLANTINGS: MAINTENANCE SCHEDULE

By design, plants in the sand filter area are meant to help filter the stormwater as it passes through and flourish throughout the growing season. The plants do not require fertilizers or mulch, and, after establishment, only need water during periods of drought. Remove and replace vegetation as necessary, using the appropriate species as discussed in the plant replacement page above. Weeding should occur quarterly during the growing season as well as monitoring for invasive species. An annual spring or fall “clean up” includes cutting last season’s growth of the perennials and removing leaves as needed. See the calendar below, the Plantings Maintenance Checklist in [Appendix B](#), Weed Identification section below and the Weed Identification Guide at <https://web.uri.edu/riss/files/In-the-Weeds.pdf> for more information.

Sand Filter Landscape Maintenance Schedule												
	Jan	Feb	Mar	Apr	May	Jun	Jul	Aug	Sep	Oct	Nov	Dec
Task	Frequency & Time of the Year											
Cutting with Shears				X								
Mowing				xxxxXxxxxxxxxxxxxxxxxXxxxxxxxx								
Weeding				X	X	X	X	X	X			
Monitoring				X	X	X	X	X	X			
Watering						x	x	x	x			
Seeding				x	x			x	x			
Plant Replacement				x	x			x	x			

- Mowed Lawn Areas
- Low to No “Mow” Areas
- All areas

- X** required
- x as needed

- Trash and debris are removed during monthly structural component inspections but can also be completed during landscape maintenance visits for weeding and monitoring.

## PLANTINGS: WEED IDENTIFICATION



Fireweed (*Erechtites hieracifolia*)



Spotted Spurge (*Euphorbia maculata*)



Crabgrass (*Digitaria ischaemum*)



Crabgrass with seedheads



Ragweed (*Ambrosia artemisiifolia*)



Japanese Knotweed (*Polygonum cuspidatum*)

PLANTINGS: WEED IDENTIFICATION



Ragweed (*Ambrosia artemisiifolia*)



Oriental Bittersweet (*Celastrus orbiculatus*)



Green Foxtail (*Setaria viridis*)



Norway Maple Tree Seedling (*Acer platanoides*)

PLANTINGS: WEED IDENTIFICATION



Catalpa Tree Seedling (*Catalpa speciosa*)



Purple Loosestrife (*Lythrum salicaria*)



Field Bindweed (*Convolvulus arvensis*)



Black Swallow-wort (*Cynanchum louisea*)

## 4.0 GENERAL SITE MAINTENANCE

---

General site maintenance includes the following requirements:

### Trash & Debris

Remove and properly dispose of all trash and debris.

### Pet Waste

Residents are encouraged to pick up after their pets. Remove and properly dispose of all pet waste left behind. Pet waste should be picked up and disposed of properly to reduce bacteria and nutrient levels in stormwater.

### Pavement Sweeping

Roadways and parking lots should be mechanically swept, at a minimum of once per year in early spring, to remove accumulated sand and sediment debris.

### Contributing Drainage Areas

Check for sources of sediment in forebay from the contributing drainage area. Follow-up with landowner(s) as necessary.

### Snow Removal

Plowed or shoveled snow piles should not block inlet structures and are not to be placed in the stormwater management areas. Due to the potential for plant damage, snow piling and or removal is NOT recommended in the sand filter.



### De-Icing

When de-icing compounds are necessary for areas draining to the green stormwater infrastructure (such as the road and parking lot), the least harmful chemicals should be used. Excessive salting should be avoided. Use of large amounts of sand should also be avoided, since it may obstruct the conveyance system. Ice removal is NOT recommended in the sand filter.



## 5.0 LONG-TERM POLLUTION PREVENTION MEASURES

---

Long-term pollution prevention measures implemented at the site reduce pollutants in stormwater discharges. The following precautions will be employed on an on-going basis.

### Spill Prevention & Control Measures

To minimize the risk of spills or other accidental exposure of materials and substances to stormwater runoff, the following material management is to be used when working on site.

- Any materials stored on-site will be stored in a neat, orderly manner in their appropriate containers.
- Products will be kept in their original containers with the original manufacturer's label.
- Substances will not be mixed with one another unless recommended by the manufacturer.
- Manufacturers' recommendations for proper use and disposal will be followed.
- The contractor's supervisor will be issued this Guide to ensure proper use and disposal of materials.

Materials or substances listed below may be present on-site for maintenance and care should be taken to avoid spills:

- Petroleum Based Products

The following product-specific measures will be followed on-site:

- [Petroleum Products](#) - All on-site vehicles and equipment will be monitored for leaks and receive preventative maintenance to reduce the chance of leakage.
- [Grass Clipping, Leaf Litter and Plant Debris](#) – are to be removed from the property and not disposed on site.

## **APPENDIX A**

---

### SAND FILTER AREA INSPECTION REPORT

## SAND FILTER AREA INSPECTION REPORT

Location:

Date:

Inspector:

Maintenance Item	Description	Maintenance (Y/N)
<b>Structural Components</b>		
<b>1, 2, &amp; 3. Collection Area / Sediment Forebay / Weir to Move Water</b>		
Debris Cleanout	Remove all trash and debris from the forebay.	
Sediment/Organic Debris Removal	Remove and properly dispose of sediment (critical when build-up is greater than or equal to 3 inches).* Remove any vegetation that sprouts through voids in stone, pavement, or pavers. Clean stone splash pad (downgradient of weir) with hose or leaf blower aimed towards forebay as necessary when clogged with sediment and/or vegetation,	
Erosion/Structural Damage	Check for areas of erosion, cracking, and/or settling in the forebay area, particularly alongside slopes and edges of weir.	
<b>Actions to be taken:</b>		
<b>4. Treatment and Management: Sand Filter Area</b>		
Debris Cleanout	Remove trash and debris from the surface.	
Side Slopes	Signs of erosion gullies, animal burrowing, overtopping or slumping are observed. Repair as necessary.	
Sediment/Organic Debris Removal	Remove sediment accumulation and properly dispose when accumulation is greater than or equal to 3 inches.*	
Vegetation Maintenance	Refer to Plantings Maintenance Checklist	
Water Draining properly	If standing water is observed for more than 48 hours after a storm event, use underdrain cleanout to remove any clogging. If still ponding, rototill or aerate 6 inches of sand filter bed to breakup any hard-packed sediment.* If standing water does not drain after tilling, replace the soil media.	
<b>Actions to be taken:</b>		

**5. Overflow Structures/Spillways: Sand filter outlet structure, level spreader/overflow spillway, and outlet to wetland**

Outlet Structure	Check for sediment accumulation, leaf litter, debris and inlet clogging that impacts inflow either at dome grate or inside at upturned PVC elbow on the outlet pipe. If sediment or debris accumulation present, schedule cleaning.	
Level Spreader	Check for settling, gulying, and erosion damage. Repair as necessary and return to design grades.	
Spillway Overflow	Look for areas of erosion in the overflow spillway between the level spreader and end of the reinforced turf swale. Repair as necessary.	
Outlet to Wetland	Check for sediment accumulation in wetland. If sediment present, remove and try to determine source. Repair any erosion and gulying as necessary by replacing/replenishing stone at outlet.	

**Actions to be taken:**

**General Site Maintenance**

Debris Removal	Remove trash from perimeter areas.	
Pet Waste Removal	Remove any pet waste from perimeter areas.	
Pavement Sweeping	Sweep parking lot/road minimum once a year after spring thaw.	
Contributing Drainage Area	Check for sources of sediment in forebay from the contributing drainage area. Follow-up with landowner(s) as necessary.	
Snow Removal	Ensure snow piles do no block inlet structures and are not placed in the green stormwater infrastructure.	
De-Icing	Do not remove ice in the sand filter. If needed, use de-icing compounds with the least harmful chemicals. Avoid excessive salting or large amounts of sand.	

**Actions to be taken:**

\*Sediment shall be disposed of offsite in a pre-approved location.

## STRUCTURAL COMPONENTS: SAND FILTER



### 3.6 Structural Components

6. **Collect:** Stormwater is captured in a slight depression (inlet) made of drivable pavers along the edge of the parking lot.
7. **Capture Sediment:** Sand and debris settle out within the permeable paver sediment forebay.
8. **Move Water:** Stormwater exits the forebay flowing over a weir structure and stone splash pad to the sand filter area.
9. **Treat and Manage:** Sand filter area media and vegetation remove nitrogen and bacteria, and allow treated stormwater to infiltrate into the soil below; when the groundwater table is high, treated stormwater is conveyed to the outlet structure via a perforated underdrain with a cleanout near the split rail fence.
10. **Overflow:**
  - c. **Outlet Structure:** Runoff volume that exceeds the design storm (1") flows into the domed outlet structure and out to the wetland via a PVC pipe.
  - d. **Level Spreader/Overflow Spillway:** Runoff from extreme storms will flow over the level spreader to the wetland via a reinforced turf overflow spillway.



# STRUCTURAL COMPONENTS: SAND FILTER

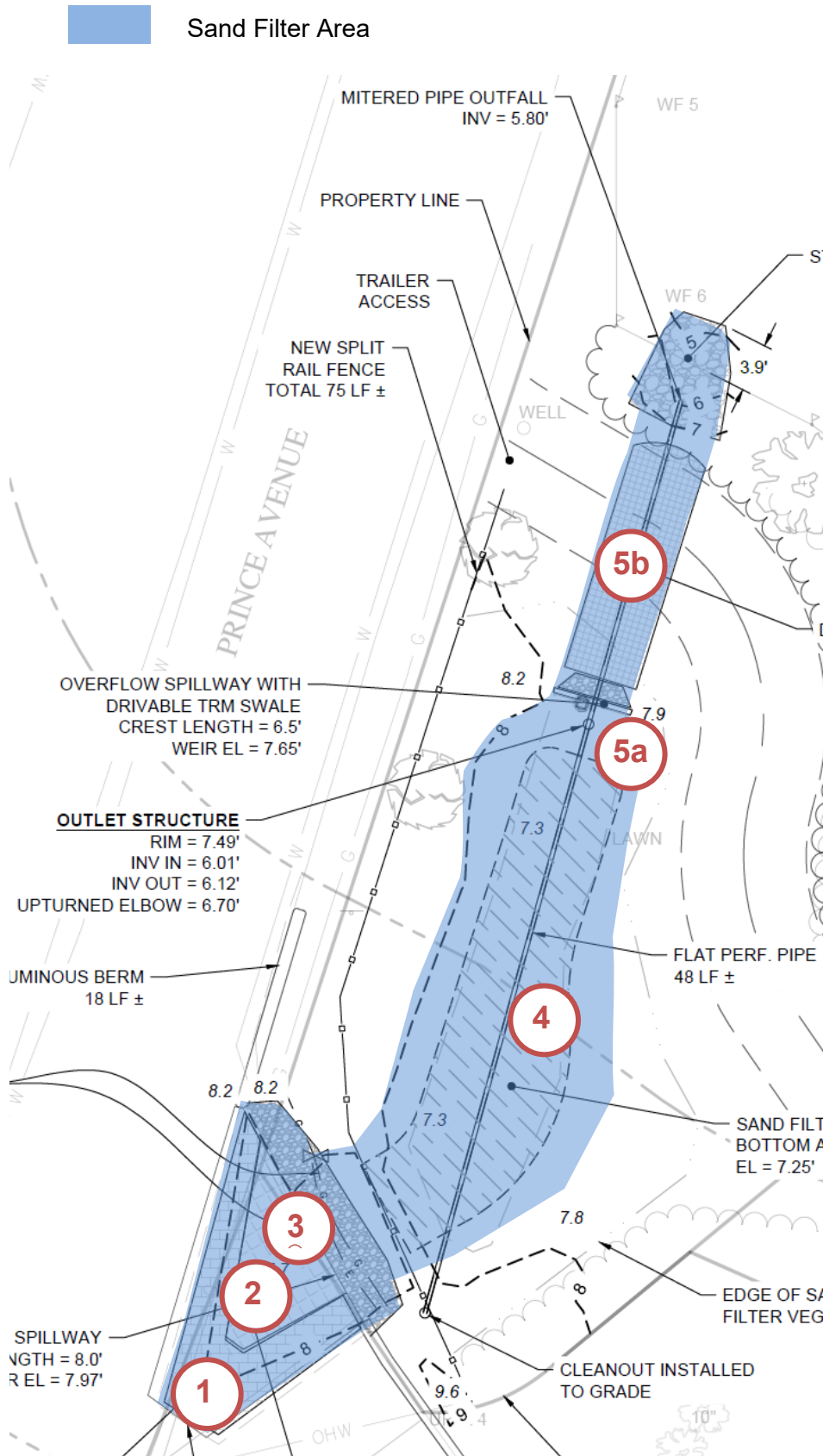

## **APPENDIX B**

---

### PLANTINGS MAINTENANCE CHECKLIST

## SAND FILTER AREA PLANTINGS MAINTENANCE CHECKLIST

**Location:**

**Date:**

**Inspector:**

Task	Description	Complete (Y/N)
Cutting	<ul style="list-style-type: none"> <li>• Leave dry standing stalks during the dormant months and remove in the spring.</li> <li>• Cut with shears at a maximum once a year in the early spring at a height no less than 6".</li> <li>• Use wooden stakes at a height of 6" for visual cues during cutting.</li> <li>• Use leafblower to move the material out of the sand filter into the sediment forebay to collect and dispose.</li> </ul>	
Mowing	<ul style="list-style-type: none"> <li>• Mow as needed with a mulching mower or weed whacker depending on the frequency of cutting.</li> <li>• Take care mowing over the turf reinforcement matting at the overflow spillway; if any matting is visible and/or sticking up above the grass, re-loam and re-seed on top of the matting to prevent it getting caught in equipment or impacting wildlife.</li> <li>• Bag clippings if there is a lot of debris and dispose of off site.</li> <li>• Maintain a cutting height of 3".</li> <li>• Leave the grass taller in the warmer months.</li> <li>• Trim edges when necessary.</li> </ul>	
Weeding	<ul style="list-style-type: none"> <li>• Weeding should be limited to invasive and exotic species, which can overwhelm the desired plant community. *</li> <li>• Non-chemical methods including hand pulling and hoeing are recommended.</li> <li>• Chemical herbicides must be avoided.</li> </ul>	
Monitoring	<ul style="list-style-type: none"> <li>• Look for potential invasive species and identify potential disease. Remove and dispose of all invasive species.* (see weeding)</li> </ul>	
Watering	<ul style="list-style-type: none"> <li>• During establishment or drought conditions, plants should be watered a minimum of once every seven to ten days.</li> </ul>	
Seeding	<ul style="list-style-type: none"> <li>• Loam and re-seed bare spots with the specified seed mix as shown on the Planting Plan.</li> </ul>	
Plant Replacement	<ul style="list-style-type: none"> <li>• Replace/replant diseases, unhealthy or dead plans to maintain a healthy plant community</li> </ul>	
Fertilizing	NONE	
Mulch	NONE	
<b>Actions to be taken:</b>		

\*Invasive species shall be disposed of offsite in a pre-approved location.

- Mowed Lawn Areas
- Low to No "Mow" Areas
- All areas



The planting design for the sand filter consists of three landscape maintenance areas:

- Mowed Lawn Areas
- Low to No "Mow" Areas
- Natural Buffers

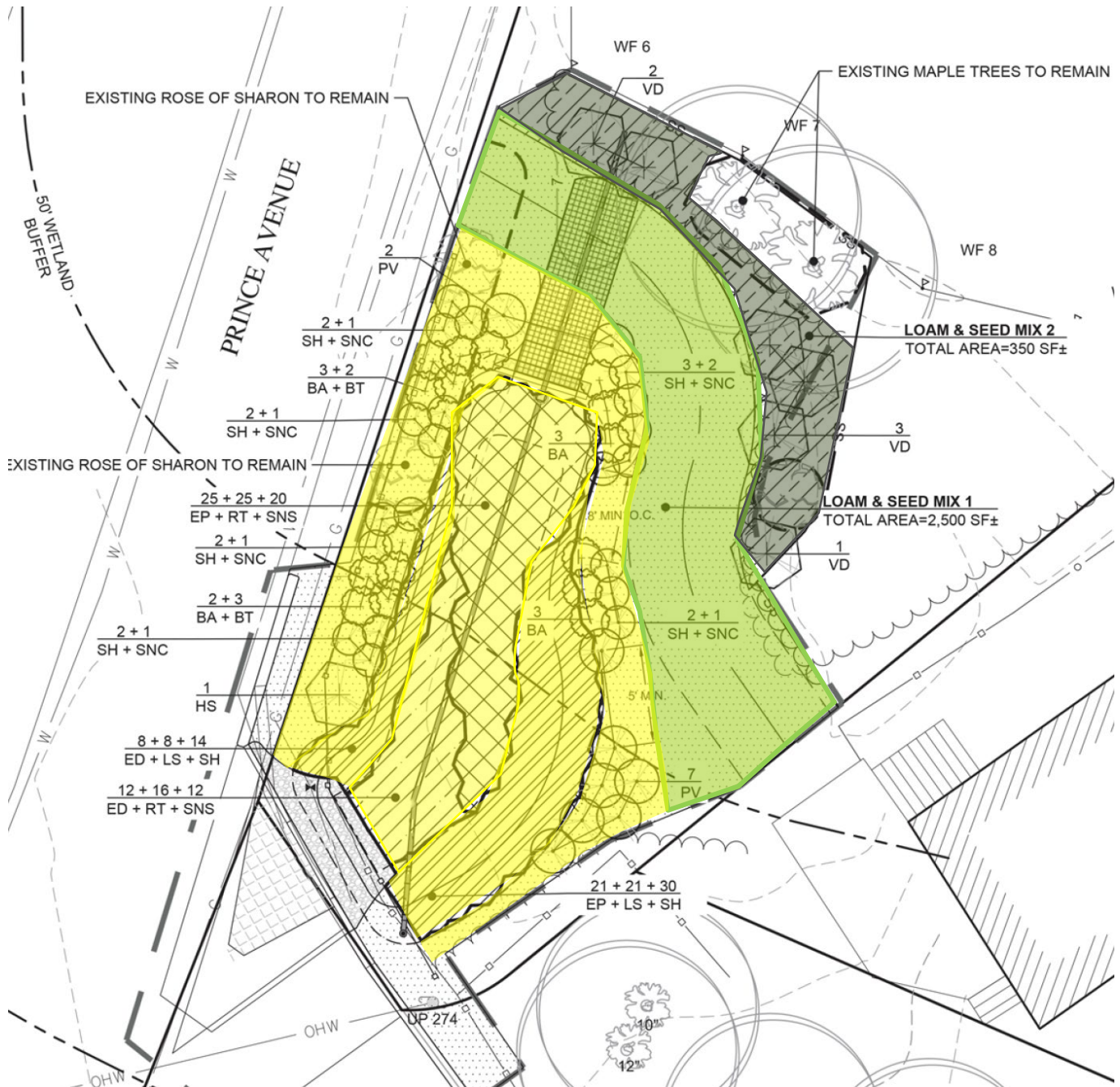

---

**APPENDIX C**  
PLANTING PLAN

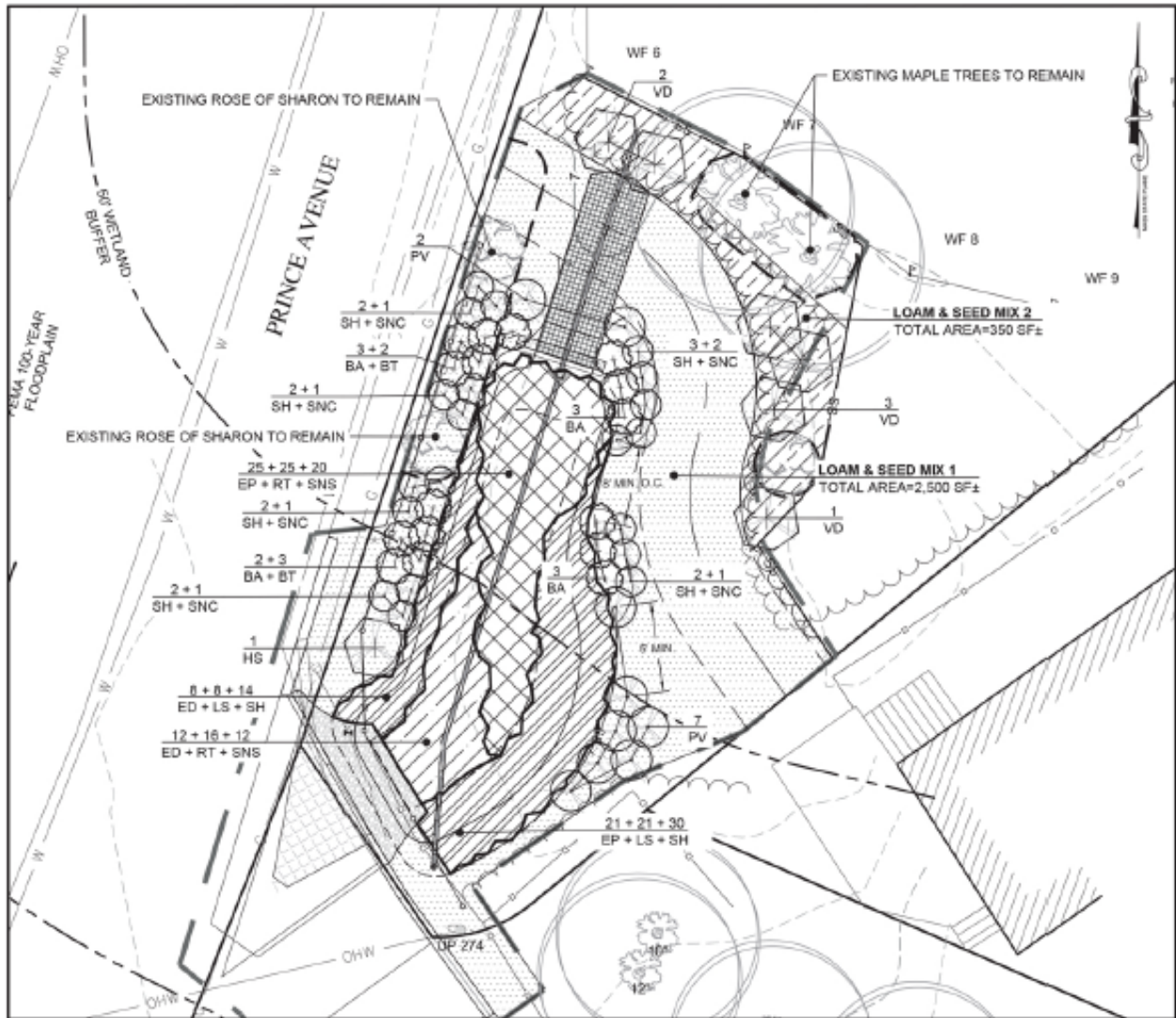

**PRINCE COVE SAND FILTER & BUFFER RESTORATION**

SCALE: 1" = 10'

**PRINCE COVE: SAND FILTER & BUFFER RESTORATION PLANTINGS**

Key	Botanical Name	Common Name	Size	Spacing
<b>Shrubs</b>				
HS 1	<i>Hibiscus syriacus</i> 'Ardens'	Rose of Sharon	3/4" B&B	As Shown
VD 6	<i>Viburnum dentatum</i>	Arrowwood Viburnum	#3	As Shown
<b>Ground Cover/Grasses/Perennials</b>				
BA 11	<i>Baptisia australis</i>	Blue False Indigo	#1	36" O.C.
BT 5	<i>Baptisia tinctoria</i>	Yellow Wild Indigo	#1	36" O.C.
EP 46	<i>Echinacea purpurea</i>	Purple Coneflower	#1	24" O.C.
ED 20	<i>Eupatorium dubium</i> 'Little Joe'	Little Joe Pye Weed	#1	24" O.C.
LS 29	<i>Liatris spicata</i>	Blazing Star	#1	24" O.C.
PV 9	<i>Panicum virgatum</i>	Switch Grass	#1	30" O.C.
RT 41	<i>Rudbeckia hirta</i>	Brown-eyed Susan	#1	24" O.C.
SNC 7	<i>Salvia nemorosa</i> 'Caradonna'	Meadow Sage	#1	24" O.C.
SNS 32	<i>Sorghastrum nutans</i>	Indian Grass	#1	24" O.C.
SH 57	<i>Sporobolus heterolepis</i>	Prairie Dropseed	#1	24" O.C.

**SYMBOL LEGEND:**



EXISTING CANOPY TREE

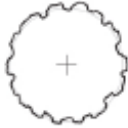

PROPOSED LARGE SHRUB



PROPOSED SMALL SHRUB



PROPOSED PLUG PERENNIAL



**SEED MIX 1 - MOW AS NEEDED**  
COLONIAL SEED - HARMONY MIX

WVYV HAIR GRASS  
SHEEP FESCUE  
HARD FESCUE  
BLUE FESCUE  
BLUE X HARD FESCUE



**SEED MIX 2 - NO MOW**  
NEW ENGLAND WETLAND - CONSERVATION MIX

VIRGINIA WILD RYE  
LITTLE BLUESTEM  
CREEPING RED FESCUE  
BIG BLUESTEM  
PARTRIDGE PEA  
DEER TONGUE  
SWITCHGRASS  
INDIAN GRASS  
OX EYE SUNFLOWER  
NEW ENGLAND ASTER  
BLUE VERVAIN  
UPLAND BENTGRASS  
COMMON MILKWEED  
FLAT TOPPED ASTER  
PURPLE JOE PYE WEED  
EARLY GOLDENROD  
GOLDEN ALEXANDER  
SPOTTED JOE PYE WEED



**SAND FILTER - MIXED PLANTINGS**  
SEE SUGGESTED PRINCE COVE PLANT LISTS

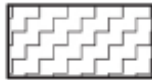

**BIORETENTION AREA**  
SEE SUGGESTED CORDWOOD PLANT LISTS

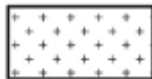

**SIDE SLOPE AREA**  
SEE SUGGESTED CORDWOOD PLANT LISTS



**RESTORATION AREA**  
SEE SUGGESTED CORDWOOD PLANT LISTS

# SAMPLE STORMWATER FACILITY MAINTENANCE AGREEMENT

THIS AGREEMENT, made and entered into this \_\_\_ day of \_\_\_\_\_, 20\_\_\_, by and between (Insert Full Name of Owner) \_\_\_\_\_ hereinafter called the "Landowner", and the [Local Jurisdiction], hereinafter called the "[Town/City]". WITNESSETH, that WHEREAS, the Landowner is the owner of certain real property described as (Tax Map/Parcel Identification Number) \_\_\_\_\_ as recorded by deed in the land records of [Local Jurisdiction] Deed Book \_\_\_\_\_ Page \_\_\_\_\_, hereinafter called the "Property".

WHEREAS, the Landowner is proceeding to build on and develop the property; and WHEREAS, the Site Plan/Subdivision Plan known as \_\_\_\_\_, (Name of Plan/Development) hereinafter called the "Plan", which is expressly made a part hereof, as approved or to be approved by the [Town/City], provides for detention of stormwater within the confines of the property; and

WHEREAS, the [Town/City] and the Landowner, its successors and assigns, including any homeowners association, agree that the health, safety, and welfare of the residents of [Local Jurisdiction] require that on-site stormwater management facilities be constructed and maintained on the Property; and

WHEREAS, the [Town/City] requires that on-site stormwater management facilities as shown on the Plan be constructed and adequately maintained by the Landowner, its successors and assigns, including any homeowners association.

NOW, THEREFORE, in consideration of the foregoing premises, the mutual covenants contained herein, and the following terms and conditions, the parties hereto agree as follows:

1. The on-site stormwater management facilities shall be constructed by the Landowner, its successors and assigns, in accordance with the plans and specifications identified in the Plan.
2. The Landowner, its successors and assigns, including any homeowners association, shall adequately maintain the stormwater management facilities in accordance with the required Operation and Maintenance Plan. This includes all pipes, channels or other conveyances built to convey stormwater to the facility, as well as all structures, improvements, and vegetation provided to control the quantity and quality of the stormwater. Adequate maintenance is herein defined as good working condition so that these facilities are performing their design functions. The Stormwater Best Management Practices Operation, Maintenance and Management Checklists are to be used to establish what good working condition is acceptable to the [Town/City].
3. The Landowner, its successors and assigns, shall inspect the stormwater management facility and submit an inspection report annually. The purpose of the inspection is to assure safe and proper functioning of the facilities. The inspection shall cover the entire facilities, berms, outlet structure, basin areas, access roads, etc. Deficiencies shall be noted in the inspection report.
4. The Landowner, its successors and assigns, hereby grant permission to the [Town/City], its authorized agents and employees, to enter upon the Property and to inspect the stormwater management facilities whenever the [Town/City] deems necessary. The purpose of inspection is to follow-up on reported deficiencies and/or to respond to citizen complaints. The [Town/City] shall provide the Landowner, its successors and assigns, copies of the inspection findings and a directive to commence with the repairs if necessary.

5. In the event the Landowner, its successors and assigns, fails to maintain the stormwater management facilities in good working condition acceptable to the [Town/City], the [Town/City] may enter upon the Property and take whatever steps necessary to correct deficiencies identified in the inspection report and to charge the costs of such repairs to the Landowner, its successors and assigns. This provision shall not be construed to allow the [Town/City] to erect any structure of permanent nature on the land of the Landowner outside of the easement for the stormwater management facilities. It is expressly understood and agreed that the [Town/City] is under no obligation to routinely maintain or repair said facilities, and in no event shall this Agreement be construed to impose any such obligation on the [Town/City].

6. The Landowner, its successors and assigns, will perform the work necessary to keep these facilities in good working order as appropriate. In the event a maintenance schedule for the stormwater management facilities (including sediment removal) is outlined on the approved plans, the schedule will be followed.

7. In the event the [Town/City] pursuant to this Agreement, performs work of any nature, or expends any funds in performance of said work for labor, use of equipment, supplies, materials, and the like, the Landowner, its successors and assigns, shall reimburse the [Town/City] upon demand, within thirty (30) days of receipt thereof for all actual costs incurred by the [Town/City] hereunder.

8. This Agreement imposes no liability of any kind whatsoever on the [Town/City] and the Landowner agrees to hold the [Town/City] harmless from any liability in the event the stormwater management facilities fail to operate properly.

9. This Agreement shall be recorded among the land records of [Local Jurisdiction] and shall constitute a covenant running with the land, and shall be binding on the Landowner, its administrators, executors, assigns, heirs and any other successors in interests, including any homeowners association.

WITNESS the following signatures and seals:

\_\_\_\_\_  
Company/Corporation/Partnership Name (Seal)

By: \_\_\_\_\_

\_\_\_\_\_  
(Type Name and Title)

The foregoing Agreement was acknowledged before me this \_\_\_\_ day of \_\_\_\_\_, 20\_\_\_\_, by \_\_\_\_\_.

\_\_\_\_\_  
NOTARY PUBLIC  
My Commission Expires: \_\_\_\_\_

By: \_\_\_\_\_

\_\_\_\_\_  
(Type Name and Title)

The foregoing Agreement was acknowledged before me this \_\_\_\_ day of \_\_\_\_\_, 20\_\_\_\_, by \_\_\_\_\_.

---

NOTARY PUBLIC

My Commission Expires: \_\_\_\_\_

Approved as to Form:

\_\_\_\_\_  
[Town/City] Attorney Date