

Unpaved Road Standards for Caribbean and Pacific Islands

2021



Prepared for:
NOAA Coral Reef Conservation Program
and Restoration Center

Prepared by:
Horsley Witten Group, Inc.
and Protectores de Cuencas

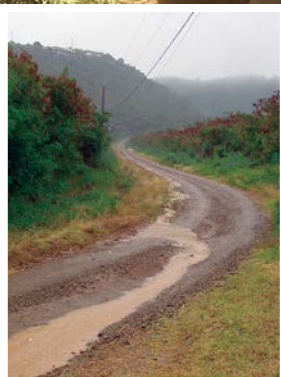

Suggested citation:

Kitchell, A., B. Kuchar, and R. Viqueira Ríos. 2021. Unpaved Road Standards for Caribbean and Pacific Islands. Prepared for the NOAA Restoration Center and Coral Reef Conservation Program. 71 pp.

This manual was funded through NOAA Coral Reef Conservation Program Order No. DG-133C-12-BA-0056/C-0014 under Contract No. GS10F0304T.

Table of Contents

About This Guidebook	1
Part 1: Unpaved Road Basics	2
The Problem with Unpaved Roads	3
Unpaved Road Principles.....	4
Road Features & Erosion Factors.....	4
Planning Considerations.....	14
Practice Selection & Design.....	14
Construction Measures	16
Maintenance Planning	17
Part 2: Design & Maintenance Standards	22
Applicability.....	23
Recommended Standards	23
Part 3: Municipal Unpaved Roads Program	28
Municipal Programs	29
Inventory and Assessment	29
Road Maintenance	30
Regulations and Standards.....	33
Permitting and Enforcement	33
Program Funding	36
Education and Training.....	37
Part 4: Drainage Control Practices	38
Grade Breaks	40
Dips & Low Water Crossings.....	41
Waterbars.....	45
Cross-drains & Culverts	47
Ditches	53
Turnouts	57
Sediment Traps.....	58
Geosynthetics.....	60
Soil/Aggregate Stabilizers	62
Slope Stabilization	64
References	71

About This Guidebook

To the best of our knowledge, this is the first guidance manual aimed at improving the longevity of unpaved road surfaces in Pacific and Caribbean island jurisdictions. On small, steep islands, the unpaved road network can be one of the biggest sources of sediment transport to nearshore marine ecosystems. Given the beat-down coral reefs are taking globally, the least we can do is improve water quality conditions so these critters can focus their survival efforts on recovering from disease and adapting to warming temperatures, ocean acidification, and overfishing. Public works officials, residents, and visitors agree that there are real economic advantages to keeping dirt where it belongs. Loss of road surface materials every time it rains is, literally, money down the drain.

This guidebook is intended to help users identify the cause of unpaved road erosion; develop a strategy for addressing the problem; and implement that strategy on a specific road, or on a larger, ecologically-meaningful scale (i.e., watershed or municipality). This guide does not provide extensive detail on road BMPs, which is covered in other publications (see references). Rather, the focus is to recommend design standards and appropriate practices to minimize erosion, improve drainage and accessibility, and reduce the long-term maintenance burden of unpaved roads. More importantly, this guide offers suggested elements for building or improving municipal road programs to ensure that unpaved roads do not become a chronic sediment source or public nuisance.

Every road is unique, as are local island jurisdictions. The information presented here is based on over a decade of collective experience in Puerto Rico, US and British Virgin Islands, Mustique, Hawaii, CNMI, Guam, American Samoa, and the Republic of Palau. Not all of the



recommendations presented here may be easily implemented in your community. Regardless, if your island does not have a mechanism to ensure proper design and long-term maintenance of unpaved roads, then, what are you waiting for?

The guidebook is organized into four parts:

Part 1: Road Basics—describes the relationship between unpaved road design, drainage, erosion, and maintenance.

Part 2: Design and Maintenance Standards—recommends 12 unpaved road standards for the Caribbean and Pacific regions. Vermont’s Municipal Roads General Permit provided an inspirational platform for developing these island standards.

Part 3: Municipal Unpaved Roads Program—identifies key elements of an effective municipal road program for each jurisdiction to consider adopting.

Part 4: Drainage Control Practices—provides 10 fact sheets on the design, installation, and maintenance of common drainage control and stabilization practices used in the islands. Many of the graphics used here are borrowed from the Center for Dirt & Gravel Roads Studies and the Vermont Better Backroads Program.

Part 1: Unpaved Road Basics

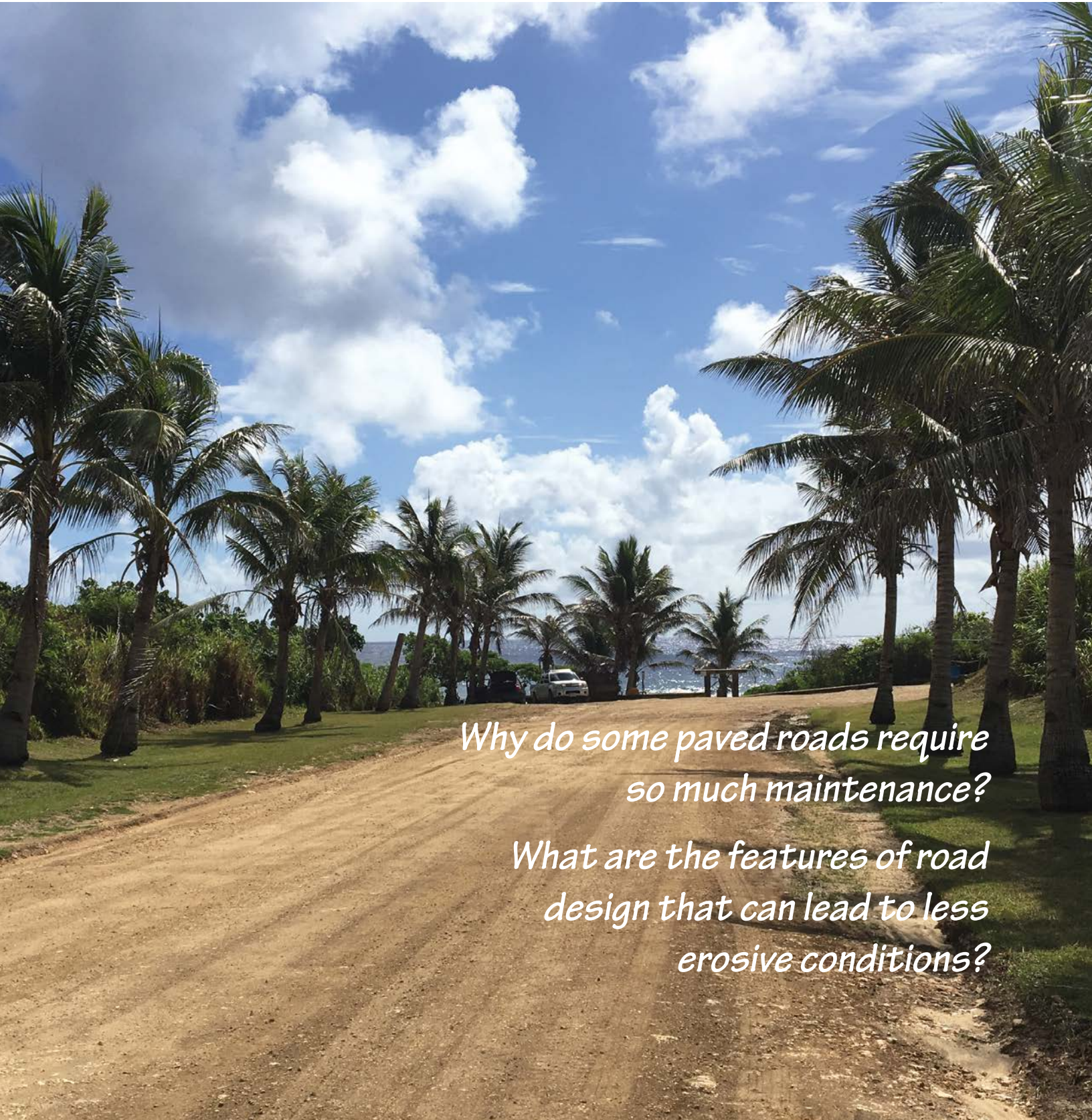

*Why do some paved roads require
so much maintenance?*

*What are the features of road
design that can lead to less
erosive conditions?*

The Problem with Unpaved Roads

On high-gradient islands in the tropics, erosion of unpaved roads can be a significant and chronic source of sediment that can degrade streams, wetlands, and nearshore coastal waters. In fact, studies in Puerto Rico have shown that unpaved roads can generate sediment at a rate of up to four orders of magnitude greater than undisturbed lands (Ramos-Scharrón and MacDonald, 2005).

Not only are sediment plumes detrimental to aquatic ecosystems, transport of sediment onto paved roads can clog drainage infrastructure and become a public safety concern. Rutted and muddy road surfaces can render unpaved roads impassable, and when poorly repaired, can lead to increased maintenance frequency.

On many islands, unpaved roads account for more than half of the road network and a majority of the watershed-derived sediment loads to marine waters. Most of these are secondary access roads or driveways that are built and maintained by property owners with little municipal oversight.

Where private roads require permits, or when publicly-owned roads are constructed, there are often no regulations governing road layout, design, or drainage criteria.

Simply fixing individual road sections on a case-by-case basis is not sufficient to protect water resources.

It is incumbent on local managers to adopt proper design and long-term maintenance standards for new and existing unpaved roads within their jurisdiction.

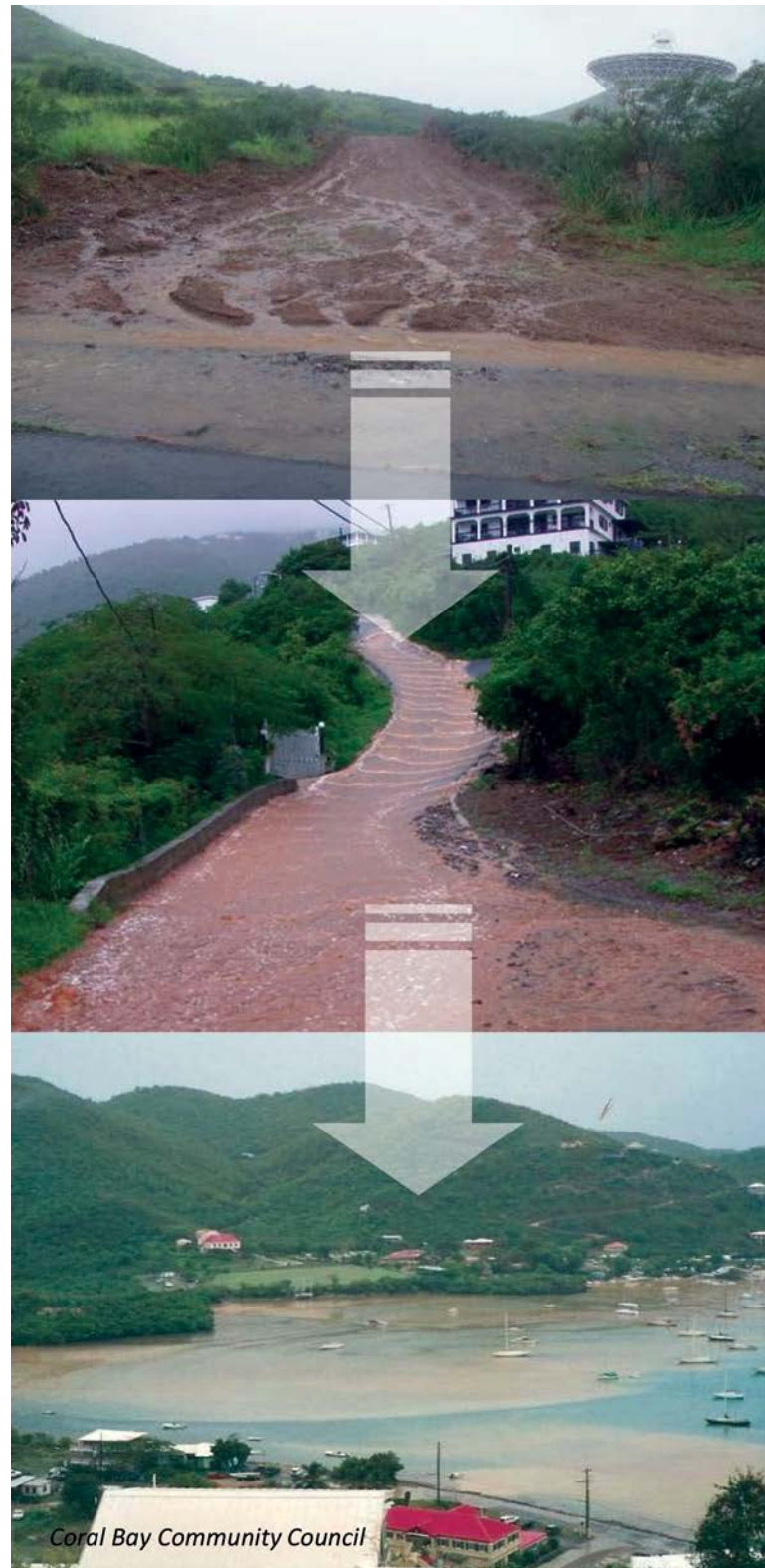

Erosion of unpaved roads can discharge sediment to connected roads and waterways, increasing road slipperiness, clogging drain pipes, and creating nearshore plumes.

Unpaved Road Principles

The three most important factors affecting the life of any road are “drainage, drainage, and drainage.” **Water is the enemy**—this is certainly true of unpaved roads. The size of the contributing drainage area, slope and length of road, and surface erodibility are key factors influencing how water impacts road conditions. Too much surface water can weaken a roadbed resulting in rutting, potholes, shoulder erosion, ditch washouts, and clogged culverts. Water flowing too slowly can deposit sediments and clog channels and culverts. Standing water can weaken the sub-base, lead to surface failure, and promote road widening as drivers attempt to avoid puddles.

With an adequate understanding of the forces acting on unpaved roads, local managers can arm themselves with the necessary tools to enhance these roads while protecting downstream water quality. Basic to any good road, especially unpaved roads, is proper design, construction, and maintenance. Yet, few unpaved roads were planned correctly in the first place, constructed as designed, or maintained properly.

The six key principles of good unpaved roads are:

1. Get water off the road quickly to prevent flows from concentrating or ponding on the surface.
2. It is better to disperse water rather than to collect it.
3. Maintain proper road cross slope and surface compaction.
4. Stabilize all conveyance ditches, outfalls, and slopes.
5. Disconnect from paved surfaces.
6. Commit to routine, long-term maintenance in order to minimize frequency of grading and major repairs.

Road Features & Erosion Factors

Figure 1 illustrates the basic features of an unpaved road. Road slope, position, composition, and cross slope are key factors influencing erosion.

The **steepness** of a road factors into the magnitude of erosive forces created by runoff because, as road slope increases, runoff concentrates more quickly and can attain higher velocities (**Figure 2**). Ideally, unpaved roads will have a 10% or flatter grade, but it is not uncommon to see island roads with 30% or greater slope.

The position of a road on a hill and the size of the contributing **drainage area** can influence the amount of runoff volume coming to each road segment.

Road segments located at the bottom portion of a hillside with largest drainage area will generally receive more runoff than a segment of road at the top of the hill.



The last place you want concentrated flows is in the travel lane, since this will lead to erosion.

Figure 1. Features of a Road

Adapted from VT Better Backroads Erosion Inventory Assessment Manual, 2015

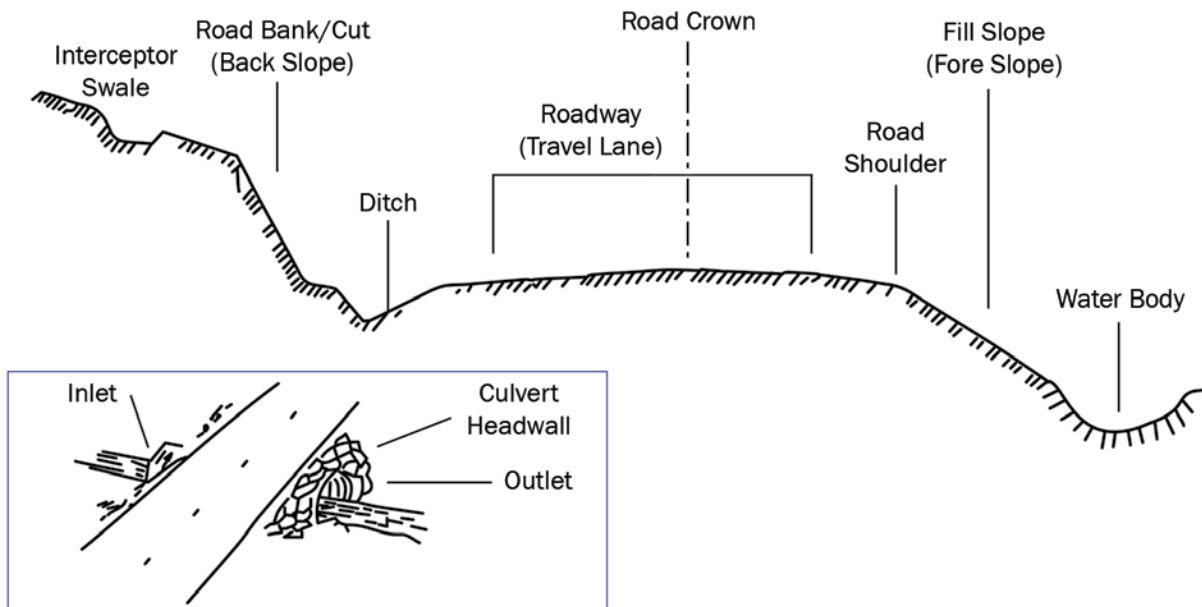

The road **cross-slope** or pitch will dictate which drainage structures are used, such as ditches, cross drains, etc. **Figure 3** shows outsloped, insloped, and crowned road profiles. Many roads will have segments of varying pitch, but generally, a 3-6% pitch is desired. Outsloped roads are preferred, since sheet flow is distributed off of the road surface. Original road shape will be lost overtime due to traffic, erosion, and maintenance activities. See **Box 1** for methods to estimate pitch and slope. Changes in road shape without adjustments to drainage controls can result in road failure.

The surface **material** and **gradation** (particle size) of unpaved roads is also an erosion factor. Ideally, a road surface will contain a mixture of both fine and coarse aggregate compacted over a base course (**Figure 4**). These surfaces can last 3-5 years without reshaping. Many island roads, however, are constructed simply by grading the native surface material exposed during clearing rather than bringing in aggregate from off-site.

Because these “dirt” roads do not have an adequate gradation of material, they: 1) are unable to be properly compacted and are highly prone to erosion; 2) may erode down to bedrock, making drainage adjustments nearly impossible; and 3) will require frequent resurfacing.

Loss of road shape, lack of drainage controls, and inadequate maintenance are big contributors to erosion issues. Erosion patterns can serve as visual clues for diagnosing drainage problems and identifying solutions (**Figure 5**).

Structural drainage controls for unpaved roads can be strategically installed to disperse, intercept, and direct flows to minimize the length of time water is on the road surface. Common **control practices** are shown in **Figure 6** and described in Part 4 of this guide.

Figure 2. Road Steepness and Erosion Risk

(adapted from the Vermont Better Backroads Manual, 2009)

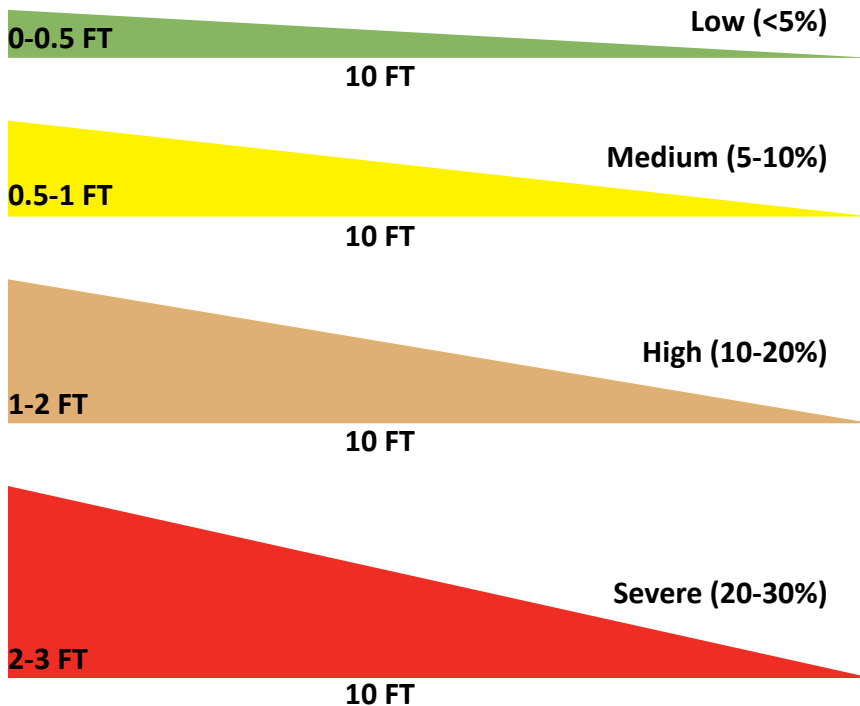

Low gradient roads (flat) don't allow runoff to build up enough velocity to cause erosion problems, under normal conditions.

Fairly steep roads will have the potential for erosion and sediment transport, if left unmanaged. Good drainage design is critical.

Very steep roads likely will have severe erosion problems and will require frequent maintenance; should be aggregate surface.

Most unpaved roads are too hard to maintain at this severe slope; should be paved.

Figure 3. Road Shape/Pitch

(graphics from Environmentally Sensitive Maintenance Practices for Dirt and Gravel Roads, 2012)

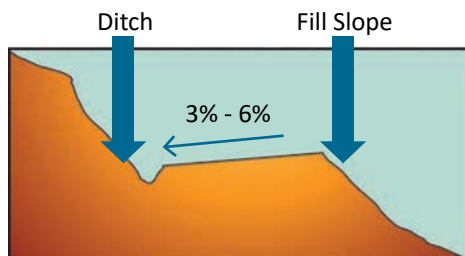

Insloped

- High point on the downhill side of road
- Drains to inside ditch, may have frequent cross culverts
- Concentrates runoff against the backslope
- Used for steep side slopes to ensure safety or where outsloping could cause erosion or instability
- Directs flow away from fill slope

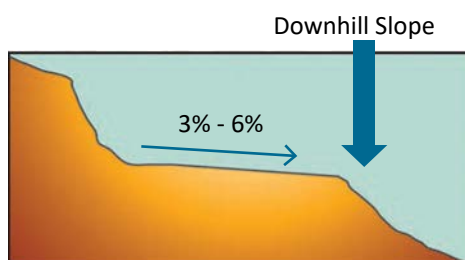

Outsloped

- High point on the uphill side of road
- Eliminates ditches and need for cross-culverts, best for dispersed flows
- Drains to downhill side
- Typically used on road slopes less than 8%
- Avoid where unsafe drop off exists below roadway

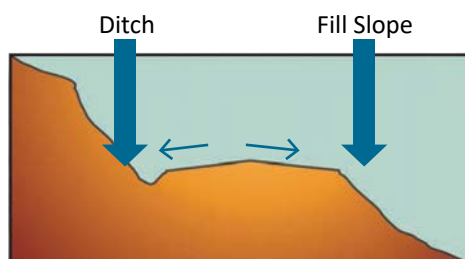

Crowned

- Shape road with a high point in the centerline and continues fall towards both shoulders-generally at least 1/2 to 3/4 inch of fall per foot across road (4-6%).
- Fastest water removal - drains in either direction
- May require water management on both sides of road
- Most common on double lane roads
- Effective for road slopes >8%
- Avoid on single lane roads prone to rutting

Box 1. Estimating Road Slope in the Field

There are a number of methods to estimate the pitch of a road surface or the overall slope of the road. A quick field method involves using a level and a measuring tape to measure vertical and horizontal distances and calculate slope using formulas based on geometry of a right triangle (photo on the left). Be sure to use the same units for vertical distance (VD) and horizontal distance (HD). Use a calculator and the formulas/conversion tables below to generate degree, percent slope, or ratio, as needed. Digital or “smart” levels are relatively inexpensive and can generate slopes automatically (photo on the right). There are also some smart phone apps that can be used. Depending on the length of road segment, you may want to take multiple readings.



The Relationship between Degrees, Percent Slope, and Ratio

(from Washington Coastal Training Program and Greenbelt Consulting, 2004)

DEGREES (x°)	PERCENT (%)	RATIO (H:V)
2.5	5.0	
5.7	10.0	10:1
10.0	17.6	
14.0	25.0	4:1
18.0	33.5	3:1
19.3	35.0	
20.0	36.4	
24.2	45.0	
26.1	49.0	
26.6	50.0	2:1
30.0	57.7	
33.0	66.7	1.5:1
35.0	70.0	
38.6	80.0	
42.0	90.0	
45.0	100.0	1:1
55.0	142.8	
60.0	173.2	

Slope Determination Formulas

Slope Ratio: HD:VD

Slope Percent: $\left(\frac{VD}{HD}\right) \times 100$

Slope Angle: $\text{Arctan}\left(\frac{VD}{HD}\right)$
(degrees)

Example →

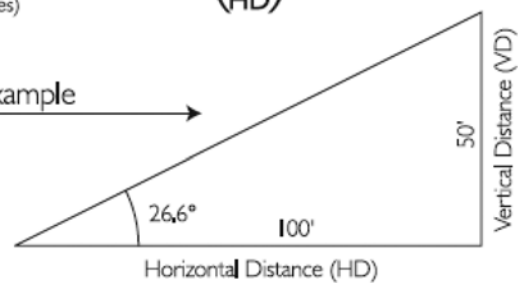

Examples

Slope Ratio: $100:50 = 2:1$

Slope Percent: $\left(\frac{50}{100}\right) \times 100 = 50\%$

Slope Angle: $\text{Arctan}\left(\frac{50}{100}\right) = 26.6^\circ$
(degrees)

Figure 4. Unpaved Road Surfacing

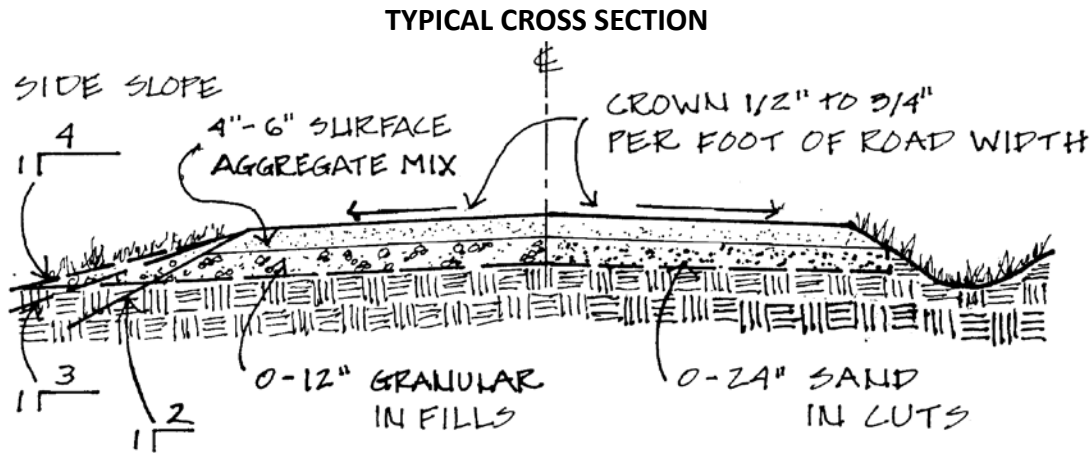

(Source: MA Unpaved Road BMP Manual, 2001)

ROAD SURFACE MATERIAL

THE SURFACE OF UNPAVED ROADS IS COMPOSED OF A MIXTURE
OF COARSE AGGREGATES AND FINE MATERIAL (FINES).



(Source: Recommended Practices Manual, A Guideline for Maintenance and Service of Unpaved Roads, 2000)

To illustrate the importance of a well-graded surface aggregate, the figure to the right illustrates the aggregate gradations of Pennsylvania's approved driving surface aggregate (DSA). DSA is a mixture of crushed stone developed specifically as a surface wearing course for unpaved roads. It has a unique particle size distribution designed to maximize compaction density and produce a durable road surface that performs better than conventional aggregates. The specification is well graded from large pieces that give support, all the way down to the "fines," rock particles less than 1/300th of an inch that serve as a binder.

A similar mix may not be replicable in the islands, however, a surface course containing a compactable mix of gravels and 10-15% fines is ideal.

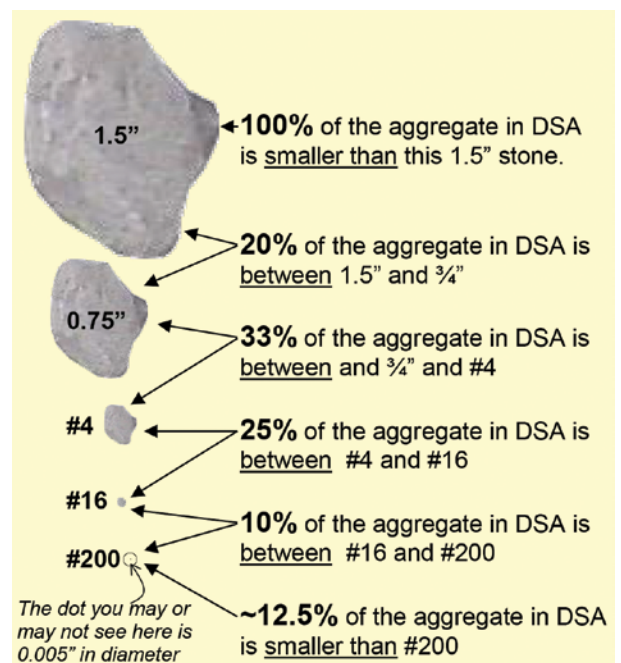

Source: Driving Surface Aggregate Handbook, 2017

Native Materials

In many cases, unpaved roads are constructed with only one layer using native materials uncovered onsite. Rarely are aggregates brought in to create an adequate base course or well-graded, compacted surface course.



Native soil, when loose and unconsolidated is highly prone to erosion. High clay content can make it slippery when wet.

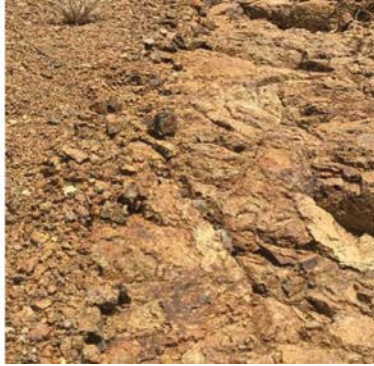

Bed rock below thin layer of sediment. Makes creation of ditches and installation of cross-drains almost impossible.



Limestone can form hard surface crust, that is easily undercut and subject to extreme rutting on steep slopes.

Open and Well-Graded Aggregates

Aggregate stones and gravels are ideal materials for stable unpaved road surfacing. Larger gradations are better for base courses, with smaller, densely graded materials used for surface courses.



Shown here are 1"-3" stones used as a base course. This stone is also good in ditches and as choker stone in riprap applications.



Smaller angular, 3/4" gravel serves as a good void filling component for compacted surface courses and for backfilling check dams.



Example of well-graded gravel surface that incorporates fines for better compaction; holds up better to traffic than loose gravel.



Pozzalana is a volcanic ash material that takes on cementitious properties when combined with water. The Romans built roads out of it, and, where available, it serves as a highly durable road surfacing material.



In some islands where volcanic rock is not available, crushed limestone may be the only surfacing option. Use a mix of graded material to improve compaction and possibly cement-treated base or lime as a binder.



Figure 5. Common Erosion Patterns on Unpaved Road



Rill: small, shallow, braided channels that do not cut much below the upper surface (a few inches only).
Raveling: loss of course aggregate. Correct by grading or blading to improve surface composition.
Dust: loss of fines- correct with better compaction and stabilizer.



Rutting/gullying: active down-cutting that creates deep, longitudinal depressions in the wheel paths caused by high moisture content, inadequate course thickness/strength, lack of drainage controls, or heavy traffic. Needs stronger base course or geosynthetics.



Potholes: “holes” in surface caused by excessive moisture, poor drainage, and poorly-graded aggregates. Correct with spot grading or patching with crushed aggregate. Stronger base layer and geotextiles can help.



Washboards: series of ridges or depressions across surface caused by lack of surface cohesion and excessive vehicle speeds. Correct by remixing surface, scarify while damp, re-grade, and compact.



Slumping or sloughing: where water under cuts the soil or saturates a steep bank leading to a collapse.



Scour: erosion in ditches, at outfalls, or culverts where velocity of runoff has cut into bank or bed surface.





Depressions: localized low areas >1 inches below road surface caused by settling, improper drainage, exacerbated by traffic. Correct by filling with well-graded aggregate, grading, and compacting.



Soft spots: muddy sections of road caused by lack of drainage. May need to replace road section with new base and surface material, geosynthetics, and/or add drainage BMPs, such as dip or culvert.

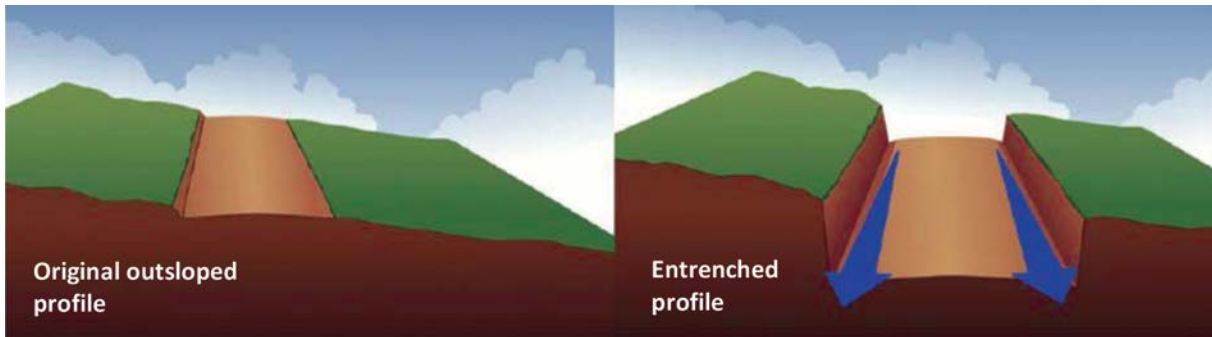

Entrenchment: where the road surface elevation is lowered over time due to repeat grading. Elevated side shoulder prevents water from draining off the road surface. Correct by raising elevation of road surface. (Graphic from Environmentally Sensitive Road Maintenance: Practices for Dirt and Gravel Roads, 2012)

False ditch: eroded gully on the outer edge of travel lane caused when ditch becomes disconnected from surface flow due to build up of material in the shoulder (e.g., windrow, vegetation, grader berm). Correct by removing material buildup that is blocking positive drainage, filling, and compacting false ditch; ensure proper pitch on road.

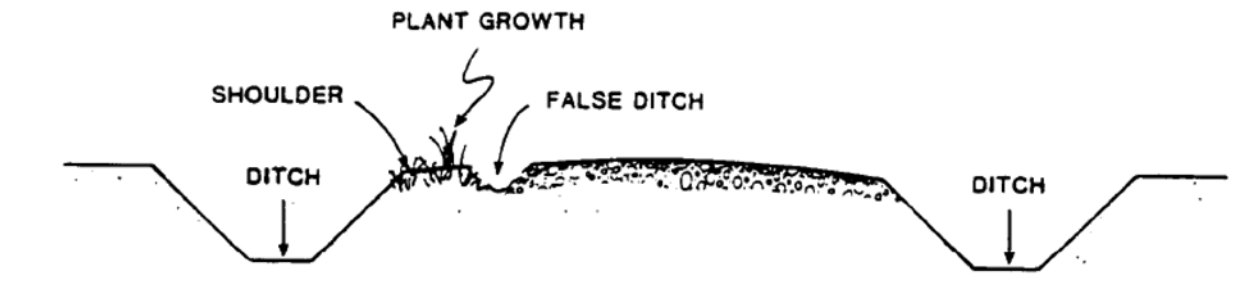

Figure 6. Common Drainage Controls for Unpaved Roads



Cross-drain: piped or open top culvert that conveys concentrated flows from one side of road to other, usually from an inside ditch to the outslope.



Dip/Low water crossing: broad pad at low point intended to convey and disperse surface flows to an outlet. Sometimes combined with wide berm.



Ditch: parabolic, V-cut, or trapezoidal channel adjacent to road used to convey concentrated flows; usually has check dams and is vegetated or stone lined.



Grade Break: using subtle elevation changes to break up surface drainage areas.



Geosynthetics: grid, mesh, or textile that adds structure to stabilize surface or subbase, distribute vehicular weight, or enhance subsurface drainage.



Slope Stabilization: Vegetation, stone, matting, or combination of techniques to prevent erosion of cut or fill slopes.





Stabilized Outfall: stone, vegetation, or other method of preventing scour at outlet structures.



Strategic Paving: Paving sections of road that are highly susceptible to erosion, such as steep inclines and turns.



Soil/Aggregate Stabilizers: Additive used to increase adhesion and longevity of road base materials. Some products may be toxic to aquatic life and are not recommended for use in sensitive watersheds.



Trap: Temporary storage areas where flows can be directed and allowed to evaporate, infiltrate, or retained for water quality or flood control purposes.



Turnout: designated location where a ditch can discharge and safely disperse flows into vegetated area.



Waterbar: linear berm installed diagonally across travel way designed to intercept flow from the road surface and discharge to stable outlet.



Planning Considerations

When planning for a new, unpaved road (either temporary or permanent), it is good practice to:

- ☑ Delineate the contributing drainage area and look to eliminate off site sources, including other roads or driveway tie-ins.
- ☑ Identify downstream flow paths, low points, and existing environmental resources or infrastructure that may receive runoff.
- ☑ Determine shape/pitch, anticipated usage/traffic load, safety issues, and road surface material type (aggregate or dirt).
- ☑ Consider paving in high use areas and on very steep slopes to minimize sediment transport.
- ☑ Minimize the overall footprint– keep road widths to a minimum needed to convey expected road usage.
- ☑ Shape roads to shed water and prevent accumulation and concentration of flows on the road surface. Plan for interception, collection, and dispersal of surface drainage.
- ☑ Identify staging areas to minimize unnecessary disturbance during construction and maintenance.
- ☑ Provide a plan for temporary sediment and erosion control during construction.
- ☑ Provide a simple O&M plan for future maintenance (e.g., identify key grades, outlet locations, and spots where sediment removal is required).
- ☑ Select drainage practices based on material availability, constructability, maintenance burden, and site constraints. For example, if bedrock is at the surface, then digging ditches or pipes below grade may be challenging.
- ☑ Specify road bedding and surface aggregate and compaction standards in contracts. Pave or use surface aggregate when necessary (>10% slope use aggregate, >20% slope pave).
- ☑ Use interceptor/diversion ditches or berms to reduce off-site run-on.
- ☑ Protect cut slopes from erosions with stabilization BMPs such as gabion terracing, living walls, or vegetative stabilization.
- ☑ Structures used to move water off of the road surface such as dips, water bars, cross drains, and turnouts should be spaced according to road slope (Table 1), or as dictated by the landscape. Steeper roads will require more frequent placement. Box 2 describes a simple field technique for determining proper spacing.

Practice Selection & Design

In order to manage surface drainage, there are a number of structural controls that can be used, depending on the situation. Design information for common practices is provided in more detail at the end of this guidebook. When designing drainage controls, consider the following:

Table 1. Spacing Guide

	Spacing (FT)*			
	Turn-outs	Water-bars	Dips	Cross Drains
2%	250	250	300	135
5%	135	135	180	100
10%	80	80	140	80
15%	60	60	Do	60
20%	45	45	not	45
25%	40	40	use	30

**Spacing to be adjusted based on landscape features and/or drainage observations.*

- ✔ Subtle changes in road grades can help to prevent scouring and sediment transport and reduce the number of turnouts or other practices needed. Design intercepts at grade breaks.
- ✔ Conveyance measures like ditches and cross-drains should be designed to safely convey at a minimum the 10-yr storm.
- ✔ Culverts should be sized based on the size of drainage area and runoff volumes. Cross-drains and driveway culverts should be a minimum diameter of 18 inches; stream culverts should extend at least the width of the existing channel.
- ✔ Ditches >5% slope should have check dams, and/or be lined with rock or geotextile.
- ✔ Direct road drainage to stabilized outlets, vegetated areas, traps, or other treatment practice. Do not discharge to erodible soils or fill slopes without outlet protection.



Diverting flows from turnouts into treatment practices such as traps and rain gardens is a good way to filter sediment and reduce runoff volume from roads or driveway tie-ins.

Box 2. Rapid Field Assessment of BMP Spacing

When you are in the field, there is a relatively simple method to assess if the proper spacing of waterbars, check dams, and other features on a steep sloping road has been achieved. Stand at a downhill feature and look uphill towards the next immediate feature. It should be approximately at eye level.

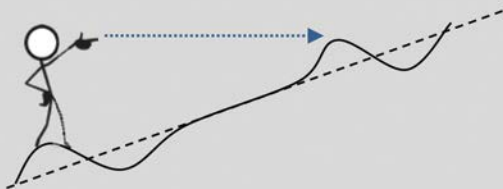

This field method is clearly not a substitute for proper surveying and design, but when combined with drainage observations, it is close enough!



Additional flow coming from the hillside should be intercepted and diverted away from the road surface with a bank bench or interceptor ditch.



Construction Measures

Construction rarely goes exactly as planned, especially if existing conditions were not fully documented. Properly constructed roads are in everyone's best interest, and a number of measures should be followed:

- ✓ Hold a preconstruction meeting with owners, contractor, and agency.
- ✓ Protect large trees or other sensitive vegetation with visible markers, changes in road layout, or plant relocation. Canopy is your friend and roots keep soil stable.
- ✓ Minimize clearing and grading footprint. Clear by hand in sensitive areas or use a phased approach. Cut vegetation 3 ft or higher, leaving stalks and roots to hold soil in place until grading is imminent.
- ✓ Phase road construction as needed to ensure immediate installation of drainage controls and staging areas needed for each segment. Monitor the weather and “don't bite off more than you can chew” in a day.
- ✓ Remove and stockpile topsoil for reuse.
- ✓ Balance cut and fill volumes; avoid sidestepping of cut material except where fill is needed. Immediately track and stabilize loose sidecast to prevent mobilization during storms (**Figure 7**).
- ✓ Use proper erosion and sediment control measures to prevent erosion. Stabilize cut and fill slopes immediately.
- ✓ Do not cut corners with size and material of surface aggregate. .
- ✓ Compaction, compaction, compaction.
- ✓ Provide an as-built survey or drawing showing actual road elevations and structure locations that differ from originally-approved plan.
- ✓ Never walk away from an unpaved road job that lacks proper drainage controls.

Figure 7. Road Construction Options
(from FAO Watershed Management Field Manual)

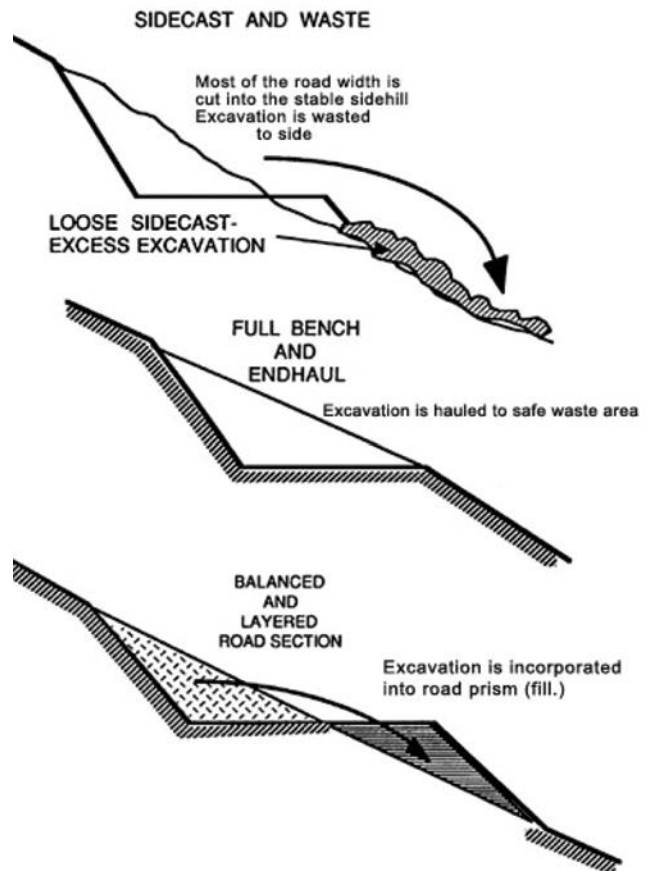

Ensuring proper compaction of the road surface is critical to extending the life of the road surface.

Maintenance Planning

Unpaved roads will require continuous inspection and maintenance for the duration of their use; therefore, the cost of long-term maintenance should be considered when evaluating the cost effectiveness of paving (**Figures 8 and 9**).

Road segments that will suffer the most erosion and require the most maintenance are those that are steep, have large drainage areas, lack proper drainage structures, consist of un-compacted dirt, and are highly traveled. While an aggressive drainage plan can be implemented to improve the longevity of the road surface, these practices will all require regular maintenance. **A good maintenance regime should strive to address the causes of erosion, not just clean up the symptoms.**

Consider the following maintenance provisions for every unpaved road:

- ✓ A maintenance plan and accompanying road map should be available that documents road shape and locations of drainage infrastructure to inspect.
- ✓ Each road should have a designated maintenance person or entity.
- ✓ Inspect roads and connected waterways after major storms.
- ✓ When inspecting roads, look for visual clues to identify maintenance needs, diagnose causes, and identify solutions (Table 2). Start at the top of the road and walk downhill during inspections. Learn how to read a ditch (Box 3).
- ✓ Use proper equipment for blading, shaping, mixing, and compacting during surface maintenance, as well as for shoulder cutting and ditch cleaning operations (See FHA, 2015).
- ✓ Maintain proper road shape and drainage during grading, which may require raising road elevation by bringing in material.

- ✓ Remove and properly dispose of any deposited materials (vegetation, grader berms, and accumulated sediment) that might block drainage, especially before significant storm events.



Rotating tipped carbide grader blades are expensive, but worth the investment due to durability, cutting and rock shattering effectiveness, and grooving that improves material compaction and binding.



Once a road becomes entrenched, it becomes a conduit for water. If drainage alternatives such as ditching and turnouts are impractical, the road profile will need to be raised.

Table 2. Common Erosion Symptoms and Solutions

Indicator	Possible Causes	Potential Solutions
Surface rills and rutting, ponding on road	Loss of road shape. Has the pitch changed? Can water get off road?	Re-grade to original shape or establish a preferred cross-slope for better drainage. May need to bring in material to raise road profile.
	Inadequate or inconsistent drainage design. Were enough drainage structures provided, if so, why are they not functioning?	Add more drainage structures to get water off road surface. Walk road starting at the top to identify locations where surface erosion starts. Look for ways to intercept or disperse flows above this location. May need to raise areas of ponding and divert flows.
	Increase in traffic or runoff volume. Is there a heavier traffic load? Has the contributing drainage area expanded?	Look for ways to disconnect flow before it gets to road. Heavier traffic load may require better compaction, more waterbars to slow traffic, or resurfacing with better aggregate course or paving.
	Lack of maintenance. Are drainage features blocked or clogged causing backup on surface? Has the road been regraded in the last 5 years?	Dirt or inadequately compacted road surfaces will release more sediment that will quickly fill in culverts, cross-drains, etc. Use shovels or equipment to remove blockages and accumulated sediment. Removed material can be mixed back into surfacing and compacted. Do not discard down the hill or in stream.
False ditch	Water cannot get into ditch because of vegetation, berm, or other change in shoulder elevation.	Remove buildup material and re-establish positive drainage from road surface. Clean out and reshape ditch. Stabilize ditch with vegetation or stone.
	Excessive erosion of road surface or ditch scour. Where is sediment coming from?	Sedimentation is a symptom of a bigger problem. Identify and address source of sediment (see surface rills and rutting and ditch erosion solutions) to retain capacity.
Sediment buildup in waterbars, pipes, ditches, etc	Lack of maintenance. When was the last time these were shoveled out? Is there a blockage?	Use shovels or equipment to remove blockages and accumulated sediment. Removed material can be mixed back into road surface and compacted. Do not discard down the hill or in stream.
	Standing or slow moving water. Is there a blockage creating backups?	Remove any blockages that may be backing water up or causing flows to slow down enough to drop sediment out.
	Incorrect waterbar, etc. alignment. Is angle sufficient?	Reinstall water bars and cross-drains that do not have a 30 degree angle to travel lane to promote self-cleaning.
Scour around culverts, cross-drains, or below outfalls	Blockage. Is the pipe clogged, collapsed, or blocked by debris?	Use shovels or equipment to remove blockages and accumulated sediment.
	Culvert undersized. Is the pipe too small to handle volume?	Divert flows upstream or replace with larger pipe. Add headers or wingwalls at inlet.
	Excessive water volume. Has the contributing area expanded?	Look for ways to disconnect flow before it gets to road. Add headers or wingwalls at inlet.
	Lack of stable outlet. Do you see scour due to lack of stone?	Add stone or other outlet protection devices. Stabilize slope with vegetation or other.
Ditch erosion or overflow	Excessive water volume. Are ditches sized for 10-yr storm?	Divert any contributing off site runoff. Stabilize slopes and maintain roadside vegetation.
	Lack of turnouts. Does the ditch need relief?	Walk ditch, starting at top. Look for opportunities above problem areas to add more turnouts or cross drains.
	Excessive velocity. Is there anything slowing flows or protecting slopes?	Add check dams. Stabilize slopes and maintain roadside vegetation. Add more turnouts or cross drains.
	Overgrown, filled in, blockages. Overflows happening due to backup or loss of capacity?	Need to restore capacity behind check dams. Unclog culverts or turnouts and remove debris. You may need to raise the road profile to reestablish ditches.



Box 3. Reading the Ditch

(adapted from *Environmentally Sensitive Road Maintenance: Practices for Dirt and Gravel Roads*, 2012)

When should a road have a ditch?

Ditches are not ideal since by their very design, they are intended to concentrate and convey potentially erosive flows. They should be used when 1) safety concerns dictate that an insloping profile is needed, 2) water seeping from a cut bank needs to be prevented from reaching the road, or 3) the road is super-elevated to accommodate heavier use and speed. Otherwise, outsloping or crowned roads are preferred.



Why do ditches erode?

Many ditches are downcut and degraded because they carry too much water and are too steep, which increases the erosive power of runoff. Ditch maintenance generally just addresses the symptom (erosion) rather than the problem (velocity and volume). Road maintenance practices that eliminate ditches or maximize the number of outlets are desirable to reduce long-term maintenance costs and to improve downstream water quality.

What can ditches tell us?

Observing what is happening (and where) in a roadside ditch can help inform decisions about road maintenance and modifications to road drainage designs. While standards exist for outlet spacing (see **Table 1**) based on road slope, for example, there will always be site-specific conditions that may better determine which practices to use and where to place them.

Factors affecting ditch stability:

- **Water Volume:** Run-on from offsite sources; Length of ditch run or size of contributing drainage area ;Subsurface springs and seeps; Road surface drainage design and effectiveness; increase in impervious cover
- **Road Geometry.** Slope, grade changes, curves
- **Soil type and texture.**
- **Number of ditch outlets** (not always easy to lead water away when you want to).

Steps for Reading a Ditch:

- ☑ **Start walking the ditch at the top of the hill.** This allows you to identify problems as soon as they become visible.
- ☑ **Follow ditch downhill, locating number of outlets.** Note location and frequency of outlets and where you see erosion occurring.
- ☑ **Look for signs of debris or scour from big events (hurricanes).**
- ☑ **Look for opportunities to create a new drainage outlet ABOVE erosion points.**
- ☑ **Estimate how long ditch can remain stable.** The distance from top of hill to first point of erosion gives a good estimate, unless there are significant changes in slope or additional drainage contributions. Use this strategy to estimate spacing for turnouts as you walk downhill.
- ☑ **Make note of additional water sources on the way down.** Look for ways to disconnect this run-on to minimize additional volumes.
- ☑ **Try to outlet ditches before curves or extremely steep road sections.**
- ☑ **Look for ways to outlet and provide sediment pretreatment prior to discharge to streams/wetlands.** Consider use of traps or sediment forebay.
- ☑ **Evaluate existing outlet condition.** If they are eroded or plugged/clogged, it might be good idea to install a new one just uphill to help disperse drainage.



Figure 8. Road Surfacing Selection

Steep slopes

When should a road be paved? Paving is expensive, but may have a lower lifecycle cost than other measures used to stabilize steep roads. Paved sections will still need drainage controls to manage runoff and prevent downhill erosion.

Mid-slope transitions

The classic two-track design is a throwback to the way we used to do things. Pave the wheel tracks and throw some loose aggregate down to prevent erosion. Stone will be washed out unless drainage is controlled in upper paved section.

Flat segments

This section of road has compacted native dirt surfacing. Likely a remnant of the original road, this section may be okay given its low gradient. A driveway tie-in adds surface runoff here. There is potential for water to pond in this location if adequate water discharge points (i.e., turnouts) are not provided.

Transitions to paved roads

An aggregate surface has been added in the section of road that ties into the main paved road. This helps reduce the amount of sediment transported onto the public roadway. This surface should last longer than the dirt surfacing.

The pressure and shear forces exerted by vehicles can create washboards and ruts in a road surface, particularly one made from non-compacted, native soils. Even aggregate surface courses can suffer surface deformations, especially as water and fines migrate upward into surface layers causing unraveling, potholes, and other issues. In most instances, our inclination is to do the least amount of maintenance as possible. In the long run, however, upgrading to a more optimal surfacing may prove to be the most cost-effective.

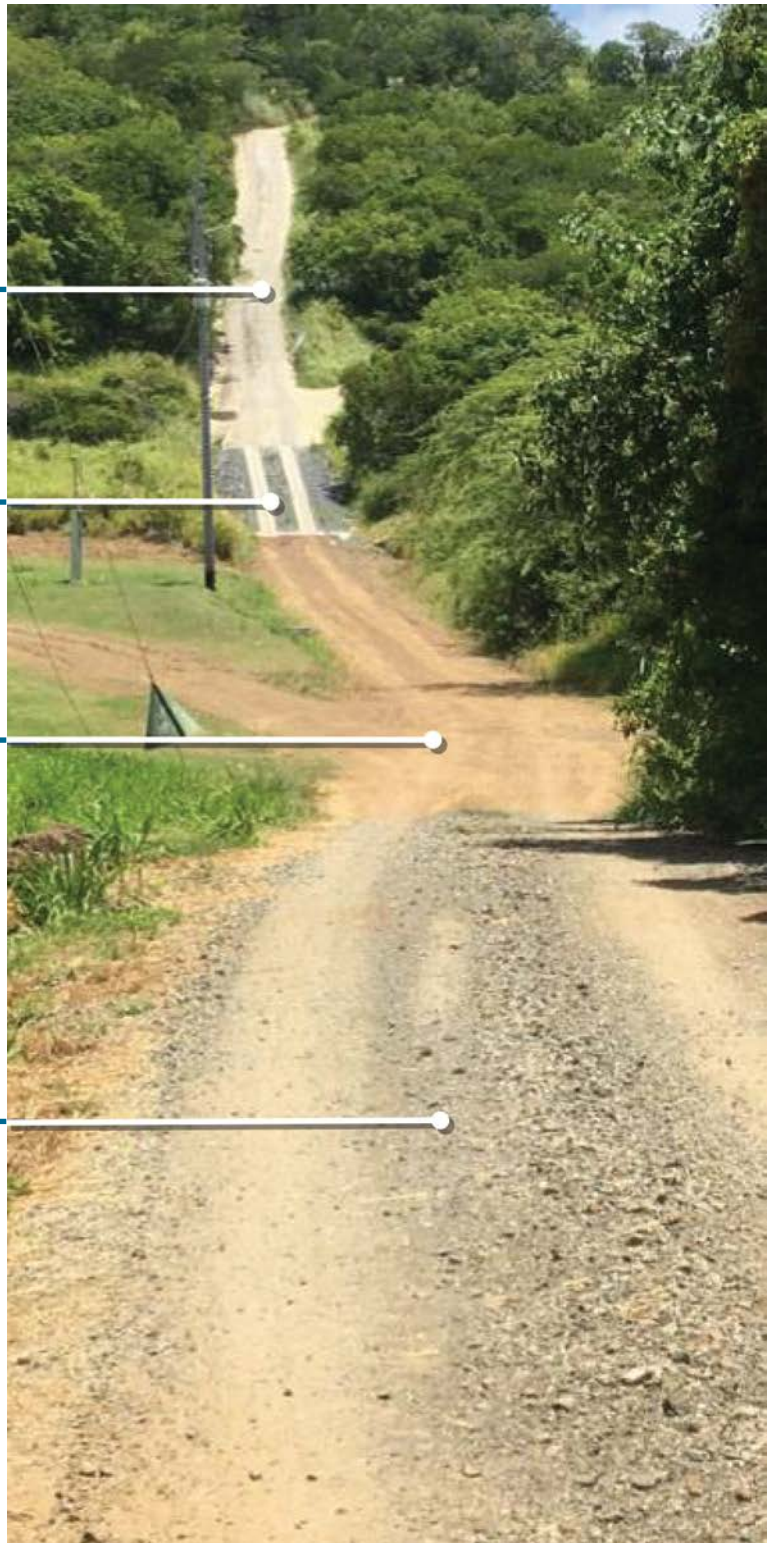

This unpaved road illustrates a combination of different surfacing techniques that (presumably) evolved over years of maintenance improvements, and provides a good case study for evaluating the longevity of various surfacing on a hillside gradient.

Figure 9. Maintenance Approaches



Least effective maintenance approach

Minimal amount of aggregate used to fill in ruts. Tempting, but this approach is not likely to last very long without reshaping of road surface, addressing drainage issues, and/or addition of full surface course.



Adequate approach

Ruts filled plus additional 4"-6" gravel layer is placed on top as a surface course. This layer should be well-graded aggregate that includes a mix of sizes including fines to promote better compaction.



Best approach

A full 4"-12" of well-graded surface course is placed on top of a reshaped and compacted 4"-12" base course. The base course is made of 2"-4" fractured rock.



Part 2: Design and Maintenance Standards



What unpaved road standards should designers, regulators, and builders follow?

Applicability

If sedimentation from unpaved roads is a water quality concern and lack of road maintenance a common complaint, consider options for improving municipal oversight of unpaved roads. Better management begins with the adoption of design and maintenance standards for unpaved roads and driveways.

These standards should be met for:

- ☑ All new unpaved road construction.
- ☑ Existing road improvements, where
 - Muddy discharges to impaired waters have been frequently observed.
 - Maintenance/repairs are being planned that involve widening, stream culvert replacement, or regrading over 100 linear feet.
- ☑ Both public and private roads, including driveways.

Recommended Standards

Table 3 provides a rationale, and offers suggested implementation tips for each of the 12 standard recommended below:

1. No unmanaged discharges to waterbodies or public roads from newly-constructed or improved unpaved roads or driveways.
2. Disconnect up-gradient impervious cover from road surface.
3. Maximum driving lane width of 10 ft (20 ft two lane travel way) for unpaved road.
4. The maximum slope for unpaved roads is 20%. If steeper unpaved sections are necessary, then aggregate surfacing, more drainage controls, and aggressive maintenance will be required.

5. Road segments within 100 ft of the shoreline must have stabilized surfaces and direct drainage to a stormwater treatment practice.
6. Provide an adequate number of turnouts for road slope, or use check dams and demonstrate that the design can safely handle the 10-yr design storm.
7. Culvert pipes should be sized properly and have a minimum 18" diameter. Stream culverts should be at least as wide as the existing channel.
8. Maintain a 3-6% pitch on in/out-sloped roads, and a 4-6% pitch on crowned roads. Road surface must be elevated above drainage features.
9. The road surface course must be compacted using a roller of 15 tons or higher (or equivalent).
10. Stabilize cut/fill slopes and associated ditches immediately.
11. All outlets should be stabilized and concentrated flows dissipated to prevent erosion.
12. New private roads require an approved long-term maintenance agreement.



The regulation of development activities varies dramatically throughout the Caribbean and Pacific; therefore, each jurisdiction is encouraged to identify locally-appropriate opportunities for integrating an unpaved road standards into their existing land development process.

In doing so, remember that only **targeting new construction does not help fix past mistakes**. Existing problem roads need to be brought up to standards. Public roads should also meet the standards, even if normally exempt from other local permitting requirements.

Table 3. Standards for Unpaved Road Design and Maintenance

Standard	Rationale	Municipal Implementation Tips
<p>1. No unmanaged discharges to waterbodies or public roads from newly-constructed or improved unpaved roads or driveways.</p> 	<p>We can no longer create new or repair existing unpaved roads without doing a better job of preventing sediment-laden discharges. This standard provides an opportunity to improve existing conditions where known discharges are causing problems, as well as preventing the addition of even more sediment loading as watersheds develop.</p>	<ul style="list-style-type: none"> • Adopt regulation and permitting procedures that require new unpaved road construction to meet these 12 standards. • Existing unpaved roads that: 1) discharge muddy runoff to impaired waters or onto public roads, or 2) are undergoing significant repairs/improvements must be retrofitted to meet these 12 standards. • Repair activities triggering compliance include widening, stream culvert replacement, cutting into the surface course, bringing in offsite material, or regrading of >100 linear ft.
<p>2. Disconnect up-gradient impervious cover from road surface.</p> 	<p>You only want to manage the runoff volume created on the road itself, not what is also generated by the surrounding hillside or driveway tie-ins. Reducing “run-on” volumes means less strain on road surface and less road maintenance.</p>	<ul style="list-style-type: none"> • Map contributing drainage areas to each road segment as part of design and permitting. • Encourage use of interceptor ditches or slope contouring to prevent flows from reaching road surface. • Require tie-ins (e.g. driveways and access roads) to disconnect drainage from the unpaved road or to upgrade drainage controls if needed to accommodate additional flows.
<p>3. Maximum driving lane width of 10 ft (20 ft two lane travel way) for unpaved road.</p> 	<p>An 18-22 ft travel way is standard and should be fine for most minor roads. Lower speed, less used roads can be on the narrower end of range. Pull outs can be added for narrower lanes to accommodate passing, pullouts, and turnarounds.</p>	<ul style="list-style-type: none"> • Width to be approved during permitting for new construction and confirmed when approving maintenance activities. • Width must be maintained over time or road design updated to reflect increase in surface area and potential loss of shoulder and original drainage controls.

Standard	Image	Rationale	Municipal Implementation Tips
<p>4. The maximum slope for unpaved roads is 20%. If steeper unpaved sections are necessary, then aggregate surfacing, more drainage controls, and aggressive maintenance will be required.</p>		<p>It can be a real challenge to manage drainage on steep roads. Try to minimize the length of steep segments by considering alternative road layouts and selective paving. Paving is expensive, but what will it cost to install and maintain all the drainage controls? Do the math before making a surfacing decision.</p>	<ul style="list-style-type: none"> • Check grades when reviewing the design plan. • Identify road segments with slopes >20% and confirm that spacing of waterbars and other drainage controls meet minimum distances in Table 1. At 20% slope, a waterbar is required every 45 ft; if grade is >35%, install a waterbar every 25 ft. Actual site conditions may dictate the frequency of practice placement. • Ensure check dams are used in ditches to slow erosive velocities and that flows are intercepted at all grade breaks.
<p>5. Road segments within 100 ft of the shoreline must have stabilized surfaces and direct drainage to a stormwater treatment practice.</p>		<p>Unpaved roads within this zone are at a low point, are conduits for larger drainage area, and have a high probability of erosion and muddy discharge. Road surfaces should be made of aggregate or paved (permeable or impervious) and the drainage should be intercepted into a rain garden, filter strip, or other BMP.</p>	<ul style="list-style-type: none"> • Denote shoreline buffer location on design plans during permitting. Identify road segments within that setback. A road segment is defined by grade breaks or other drainage changes. The entire segment should be stabilized (not just the portion within 100 ft). • Identify existing road segments within your jurisdiction that are completely or partially within the shoreline buffer. Prioritize those for retrofitting when opportunities arise.
<p>6. Provide an adequate number of turnouts for road slope, or use check dams and demonstrate that the design can safely handle the 10-yr design storm.</p>		<p>Getting water off the road surface and out of ditches is the best way to manage drainage. Often, we don't provide enough turnouts to keep the total volume of water at a manageable amount. The steeper the slope, the more turnouts needed.</p>	<ul style="list-style-type: none"> • If design is insloped, make sure you can accommodate turnouts. See Table 1 for recommended spacing. For 25% slope, one turnout should be provided every 40 ft. • If you can't meet recommendation, you must use check dams in ditches and must design for 10-yr, 24-hr storm (using most updated precipitation frequencies). Consider using an alternative road shape.

Standard	Image	Rationale	Municipal Implementation Tips
<p>7. Culvert pipes should be sized properly and have a minimum 18" diameter. Stream culverts should be at least as wide as the existing channel.</p>		<p>Pipes should be sized to handle expected flows, but many culverts are sized based on the pipes stored out back, not a hydrologic model. This leads to culverts being undersized for the amount of flow received. If anything, culverts should be slightly oversized to allow for increases in flow due to future growth or changes in rainfall patterns.</p>	<ul style="list-style-type: none"> • Delineate drainage area to each culvert (e.g., cross-drain, driveway, or stream culvert). • Evaluate size and condition of uphill and downhill conveyance structures. Consider potential for additional drainage in the future and be conservative in your sizing. • Ask engineer to provide culvert sizing calculations as part of permit.
<p>8. Maintain a 3-6% pitch on in/out-sloped roads, and a 4-6% pitch on crowned roads. Road surface must be elevated above drainage features.</p>		<p>Unpaved roads typically require more pitch than paved roads due to surface porosity and roughness. Steeper roads may require a more pronounced pitch to ensure that water flows off to the side instead of down travel lane.</p>	<ul style="list-style-type: none"> • Ensure during permitting that proper pitch is proposed for the road shape and grade. • Document pitch design in maintenance plan. • Confirm during construction. As a general rule, there should be at least 1/2 inch to 3/4 inch of fall per foot across the road (4 to 6 %). Measure in the field with a hand level. • Maintain road grade over time so runoff continues to flow as designed
<p>9. The road surface course must be compacted using a roller of 15 tons or higher (or equivalent).</p>		<p>Under-compacted roads are frequent problem leading to loss of surface material. This is particularly important for dirt roads where native soils are the only material being used for surfacing.</p>	<ul style="list-style-type: none"> • Confirm by checking equipment rating, or • Perform a compaction test during construction inspections.

Standard	Image	Rationale	Municipal Implementation Tips
<p>10. Stabilize cut/fill slopes and associated ditches immediately.</p>		<p>Road cut banks and loose fill slopes can be a continuous source of erodible material. Ditches that are un-lined, un-vegetated, or that lack check dams can begin eroding during the first rain event. These features should be stabilized prior to construction closeout. Driveway culverts should have proper headwall protection to prevent ditch erosion.</p>	<ul style="list-style-type: none"> • Visit the site to determine erodibility of any exposed banks, slopes, and ditches. • Recommend gabions, stone walls, vegetation, terracing, or combination of techniques for cut slopes, if needed. • Recommend stone or vegetation, check dams, and culvert headwalls to help prevent ditch erosion, if needed. If left exposed, require applicant to prove ditches are designed for the 10-yr storm. • Do not approve project closeout without satisfactory stabilization.
<p>11. All outlets should be stabilized and concentrated flows dissipated to prevent erosion.</p>		<p>Discharge of concentrated flows of ditches, cross drains, or turnouts can lead to erosion, particularly if discharging down a steep fill slope. These locations need to be reinforced or flows need to be slowed and spread using stone, plunge pools, or other. Dispersed flows should be directed to vegetated areas.</p>	<ul style="list-style-type: none"> • Identify proposed turnouts and discharge points during permit review and make sure they have proper protection (e.g. stone apron, plunge pool, vetiver, level spreader, or other energy dissipater). • Locate and inspect discharge points in the field to ensure that they are stabilized. • For discharges near streams and other waterbodies, follow the discharge to make sure the entire flow path is stabilized. • Adjust stone or other practice if determined that it is not working properly.
<p>12. New private roads require an approved long-term maintenance agreement.</p>		<p>Even where local permits cover road construction, the oversight generally stops there. Unpaved roads (like all infrastructure) require a lifetime of servicing. Private road owners should be planning for that long-term maintenance commitment. Who is going to do it, when will it need repair, how much will it cost, and how do we pay for it?</p>	<ul style="list-style-type: none"> • Require submittal of a maintenance plan and signed maintenance agreement as part of permit application that identifies responsible parties, annual budget, and proposed maintenance contractor. • Ensure Homeowners Associations plan for adequate maintenance funding. • Consider legal mechanisms, grant subsidies, or partnerships to share maintenance costs for existing problem roads between public and private sector.

Part 3: Municipal Unpaved Roads Program

Municipalities have enough on their plates already. How can agencies more efficiently regulate and maintain their unpaved road network?



Municipal Programs

Most jurisdictions provide some level of oversight for new road construction as part of the land development permitting process. Some jurisdictions also require permits for road regrading and repair. Where this oversight often falls short is in requiring unpaved roads to meet specific design and maintenance criteria. Municipalities also often fail to take advantage of opportunities to improve drainage conditions on existing roads.

To have an effective municipal roads program, local managers should be able to answer “yes” to the following questions:

- ☑ Do you have a map of public and private unpaved roads on the island (or within your jurisdiction)?
- ☑ Do you know the general condition of those roads and their sediment loading potential to marine waters?
- ☑ Do you have a maintenance program that prioritizes road improvements within the annual budget? Do you have the right equipment to support implementation?
- ☑ Does permitting and enforcement of new roads result in substantial compliance with unpaved road standards?
- ☑ Is progress being made on bringing existing roads into compliance with unpaved road standards?

If the answer to any of these questions is “no,” consider incorporating all or some of the components within six key program areas as described below and summarized in Figure 10.

Figure 10. Key Program Areas



Inventory and Assessment

The first step is to better understand how many miles of unpaved road there currently are, and what percentage of that network is public vs. private. Start with existing road maps available from your GIS department. Most likely, a combination of aerial photo interpretation and field verification (driving around) will be needed. A review of tax parcel information may help determine road ownership.

As part of the inventory, the definition of what constitutes an unpaved road must be determined. A good rule of thumb may be to exclude driveways that are short or where a house is visible from the road. Shared or long driveways that look and act like a road should be inventoried. Depending on resources, you can always add excluded segments in later.

Establish a preliminary unpaved roads database that includes a road ID#, name (if there is one), and ownership information, at a minimum. As more information is gathered on existing roads, the database can be expanded to include hydrologic-connectivity, road width, surfacing material, condition, drainage controls, maintenance tracking, and any associated permits.

A windshield survey (i.e. from your car or golf cart) should be conducted to determine the condition of each road segment and risk of erosion impact. Depending on how many miles of unpaved roads there are, this assessment may be phased by prioritizing roads with known issues or roads that are adjacent to the shoreline, stream, or other wetlands (hydrological-connected). The windshield survey should answer the following questions:

1. How would you rate the condition of the unpaved road surface (Table 4)?
2. Does the erosion contribute to a water quality issue? Is sediment transported to receiving waters during a typical storm event?

If a rating of 4 or less is assigned, and if sediment is discharging to a waterway, then a more detailed assessment may be needed to characterize road erosion and to identify the cause and drainage solutions. Box 4 offers an example of a detailed assessment form.

Road Maintenance

Don't be surprised if the inventory reveals that most of the roads require maintenance or reworking. Even well-designed and maintained unpaved road surfaces generally need to be reshaped within 5 years.

Table 4. Surface Condition Rating

Rating	General Condition
5	Newly constructed or improved road. Excellent pitch and drainage. No maintenance required.
4	Good pitch and drainage. Routine maintenance needed.
3	Roadway shows traffic effects. Needs re-grading, minor ditch maintenance, slope stabilization, and spot regrading.
2	Road needs regrading, additional aggregate layer, and/ or major drainage improvements.
1	Travel is difficult, especially during rain events. Complete rebuilding required.

Recognizing that resources are limited, road improvements should be prioritized using a transparent set of ranking criteria, such as:

- ☑ Erosion severity—the worst/most frequent problems, steepest, or most susceptible are highest priority;
- ☑ Public vs. private roads—generally public roads are a higher priority for municipal programs;
- ☑ Hydrological-connection to receiving waters—prioritize roads in close proximity to a waterbody where there is a higher risk for sediment transport;
- ☑ Priority watersheds—higher ranking roads within focus watersheds;
- ☑ Traffic demand—higher priority for roads that are most critical for the transportation network; and
- ☑ Feasibility—highest where partnerships, links with other projects, funding support, or educational opportunities are available.

Once ranked, managers can craft a feasible schedule and budget appropriate to address existing road problems. Annual maintenance budgets should account for equipment purchases and upkeep, as well as material and labor costs. Ideally, a roads manager will have access to a grader, backhoe, vibratory roller, hand-held compactor, and a vector truck. If a bulldozer is your primary equipment, invest in blade attachments for unpaved road surface work.

As each repair or improvement is completed, maintenance should be logged in the municipal roads database (i.e., road ID#, permit #, date, action, cost, and contractor). A maintenance plan should be created or updated, as needed, for each road. For improvements on private roads, it is recommended that a long-term maintenance

agreement is recorded, especially if public funds were used.

Separate schedules may need to be developed for public and private roads depending on how the municipal program is organized. It is likely that new programs will limit improvement activities to public roads; however, as a program matures, expansion of program activities to include private road restoration may be desired to better address water quality problems.

Figure 11 shows an example of an unpaved road inventory and initial prioritization for Culebra, Puerto Rico. Here, public and private roads were selected based on location within six priority watersheds. This evaluation is being used to establish a restoration schedule that will guide federal funding support.

Figure 11. Unpaved Road Prioritization on Culebra, PR

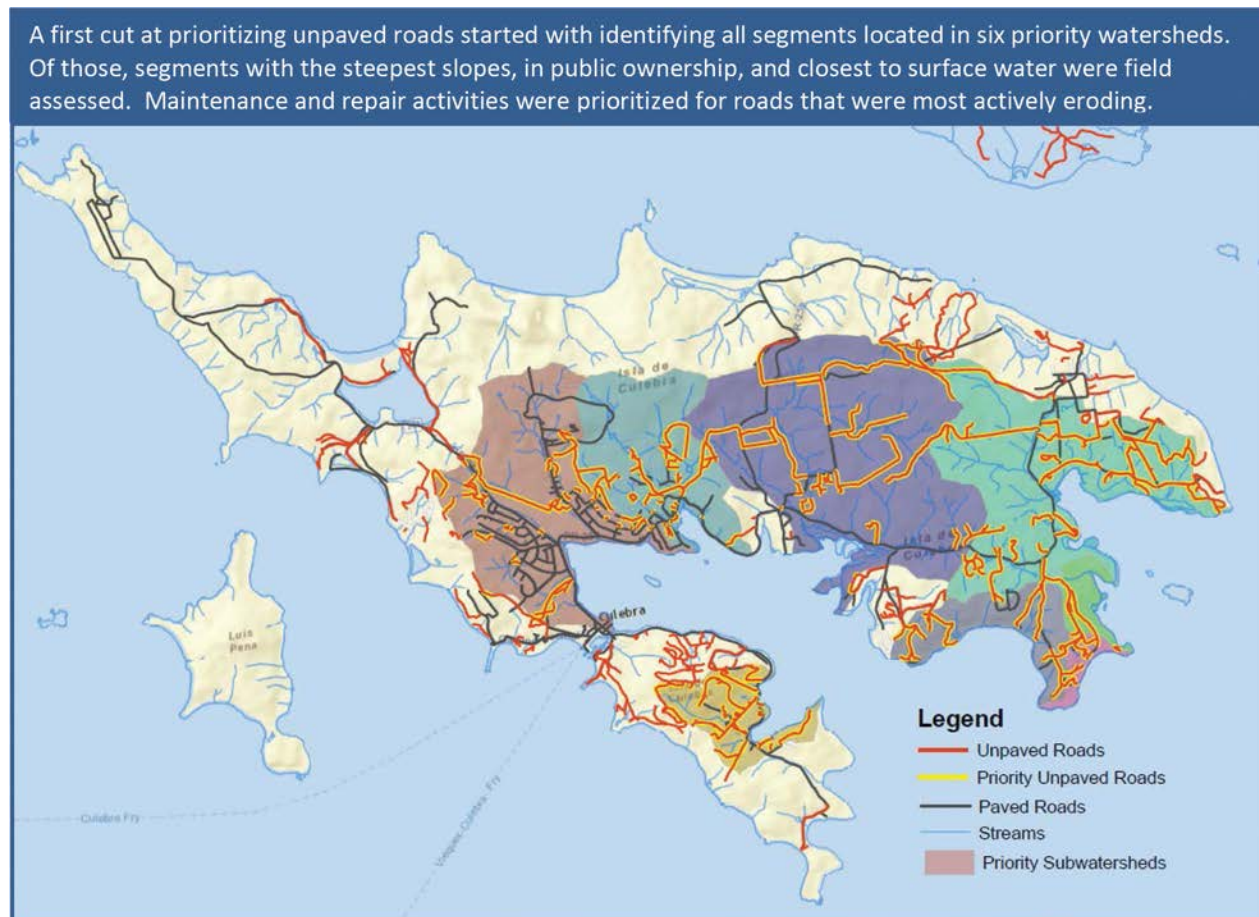

Box 4. Example Unpaved Road Detailed Assessment Form

Segment ID#:		Assessed by:	Date: ___/___/___																												
Name or Address:		Segment Sketch/Notes:																													
Watershed:																															
Ownership: <input type="checkbox"/> Public <input type="checkbox"/> Private <input type="checkbox"/> Unknown																															
Usage: <input type="checkbox"/> Heavily Traveled (primary) <input type="checkbox"/> Moderate <input type="checkbox"/> Low																															
Dimensions: Segment Length: _____ ft Surface Width: _____ ft Total ROW Width: _____ ft																															
Surface Type: <input type="checkbox"/> Native/Dirt <input type="checkbox"/> Aggregate <input type="checkbox"/> Bedrock																															
Compaction: <input type="checkbox"/> Compacted <input type="checkbox"/> Loose <input type="checkbox"/> Unsuitable																															
Road Slope: <input type="checkbox"/> ≤5% <input type="checkbox"/> ≤10% <input type="checkbox"/> ≤20% <input type="checkbox"/> >20%																															
Shape/Pitch: <input type="checkbox"/> Insloped <input type="checkbox"/> Outsloped <input type="checkbox"/> Crowned <input type="checkbox"/> ??																															
Road/Hillside Position: <input type="checkbox"/> upper 1/3 <input type="checkbox"/> mid 1/3 <input type="checkbox"/> lower 1/3 <input type="checkbox"/> ?																															
<table border="1"> <tr> <td colspan="2"><input type="checkbox"/> Erosion Observed</td> <td><input type="checkbox"/>None</td> <td>Total Score _____</td> </tr> <tr> <td>Location</td> <td>Minor</td> <td>Moderate</td> <td>Severe</td> </tr> <tr> <td><input type="checkbox"/> Road surface</td> <td><10% of segment has some rills, wash boarding, or soft spots observed 1 2 3</td> <td>10%-30% of segment, gullies, big potholes, 4WD needed 4 5 6 7</td> <td>>30% of segment has false ditches, mostly impassible 8 9 10</td> </tr> <tr> <td><input type="checkbox"/> Ditch</td> <td><10% of ditch length show signs of erosion, bottom/sides mostly stable 1 2 3</td> <td>10%-30% of length has erosion or full of sediment 4 5 6 7</td> <td>>30% of length eroded, full, or otherwise not functioning 8 9 10</td> </tr> <tr> <td><input type="checkbox"/> Culvert</td> <td>Headwalls present, some erosion around pipe ends 1 2 3</td> <td>Local scour or clogging evident at multiple pipes 4 5 6 7</td> <td>Most culverts in segment, culvert causing other erosion 8 9 10</td> </tr> <tr> <td><input type="checkbox"/> Cut slope <input type="checkbox"/> Fill slope <input type="checkbox"/> Both</td> <td><10% of slope surface is unstable. No major rills or failures. 1 2 3</td> <td>10-30% of surface eroding; some gullyng 4 5 6 7</td> <td>>30% surface bare; slope failure observed 8 9 10</td> </tr> <tr> <td><input type="checkbox"/> Outlets/turnouts</td> <td>Mostly stable with veg or rock; flows spread or dissipated 1 2 3</td> <td>Local erosion present at one or more locations 4 5 6 7</td> <td>Erosion extensive; slope failure observed 8 9 10</td> </tr> </table>				<input type="checkbox"/> Erosion Observed		<input type="checkbox"/> None	Total Score _____	Location	Minor	Moderate	Severe	<input type="checkbox"/> Road surface	<10% of segment has some rills, wash boarding, or soft spots observed 1 2 3	10%-30% of segment, gullies, big potholes, 4WD needed 4 5 6 7	>30% of segment has false ditches, mostly impassible 8 9 10	<input type="checkbox"/> Ditch	<10% of ditch length show signs of erosion, bottom/sides mostly stable 1 2 3	10%-30% of length has erosion or full of sediment 4 5 6 7	>30% of length eroded, full, or otherwise not functioning 8 9 10	<input type="checkbox"/> Culvert	Headwalls present, some erosion around pipe ends 1 2 3	Local scour or clogging evident at multiple pipes 4 5 6 7	Most culverts in segment, culvert causing other erosion 8 9 10	<input type="checkbox"/> Cut slope <input type="checkbox"/> Fill slope <input type="checkbox"/> Both	<10% of slope surface is unstable. No major rills or failures. 1 2 3	10-30% of surface eroding; some gullyng 4 5 6 7	>30% surface bare; slope failure observed 8 9 10	<input type="checkbox"/> Outlets/turnouts	Mostly stable with veg or rock; flows spread or dissipated 1 2 3	Local erosion present at one or more locations 4 5 6 7	Erosion extensive; slope failure observed 8 9 10
<input type="checkbox"/> Erosion Observed		<input type="checkbox"/> None	Total Score _____																												
Location	Minor	Moderate	Severe																												
<input type="checkbox"/> Road surface	<10% of segment has some rills, wash boarding, or soft spots observed 1 2 3	10%-30% of segment, gullies, big potholes, 4WD needed 4 5 6 7	>30% of segment has false ditches, mostly impassible 8 9 10																												
<input type="checkbox"/> Ditch	<10% of ditch length show signs of erosion, bottom/sides mostly stable 1 2 3	10%-30% of length has erosion or full of sediment 4 5 6 7	>30% of length eroded, full, or otherwise not functioning 8 9 10																												
<input type="checkbox"/> Culvert	Headwalls present, some erosion around pipe ends 1 2 3	Local scour or clogging evident at multiple pipes 4 5 6 7	Most culverts in segment, culvert causing other erosion 8 9 10																												
<input type="checkbox"/> Cut slope <input type="checkbox"/> Fill slope <input type="checkbox"/> Both	<10% of slope surface is unstable. No major rills or failures. 1 2 3	10-30% of surface eroding; some gullyng 4 5 6 7	>30% surface bare; slope failure observed 8 9 10																												
<input type="checkbox"/> Outlets/turnouts	Mostly stable with veg or rock; flows spread or dissipated 1 2 3	Local erosion present at one or more locations 4 5 6 7	Erosion extensive; slope failure observed 8 9 10																												
Sediment Transport: <input type="checkbox"/> observed <input type="checkbox"/> likely <input type="checkbox"/> low risk <input type="checkbox"/> ??		Potential Solutions/Comments:																													
Drains to: <input type="checkbox"/> waterbody, <input type="checkbox"/> public road, or <input type="checkbox"/> both																															
Distance to: <input type="checkbox"/> water <input type="checkbox"/> wetland <input type="checkbox"/> stream _____ ft																															
General Cause <input type="checkbox"/> heavy use when wet <input type="checkbox"/> poor road design <input type="checkbox"/> inadequate drainage controls <input type="checkbox"/> no maintenance <input type="checkbox"/> expanded drainage area <input type="checkbox"/> large storm event <input type="checkbox"/> unknown <input type="checkbox"/> other:																															



Regulations and Standards

As discussed in the previous section, consider adopting an unpaved roads ordinance, code, and/or regulation that includes minimum road standards. This language can be a stand-alone or inserted into an existing drainage, erosion control, or zoning ordinance.

As with any regulation, an applicability provision, administrative procedures, and enforcement mechanisms will need to be included. The regulation should clearly articulate a rationale for addressing new construction, as well as bringing existing roads up to standards during repairs and improvements. The regulation should include drainage requirements for driveways and access roads proposing to tie into the existing road network (e.g., disconnection or upgrades to downhill infrastructure). It may also be worth including a provision in the regulation that provides jurisdictional authority to adopt or conduct road maintenance on private roads with chronic drainage problems on a case-by-case basis.

Unpaved road permit requirements for driveways and tie-ins help municipalities limit the impacts of drainage from private roads and driveways onto public roads and into waterways.



Ideally, a roads program will be administered by the local public works department or mayor's office, depending on who is responsible for maintaining public roads. However, if the building or planning department is the primary permitting agency, having a coordinated approach between these entities may be appropriate.

Permitting and Enforcement

The most common form of local oversight is through a permitting process. As such, municipalities should create a new unpaved road permit (or integrate within an existing permit) required for:

1. All new unpaved road construction;
2. Maintenance and repair activities for existing unpaved roads where widening, stream culvert replacement, or regrading over 100 linear feet is planned; and
3. Proposed driveways or other unpaved access road tie-ins into an existing paved or unpaved road.

The permit applications should include the following information:

- ✓ A checklist documenting compliance with each of the 12 unpaved road standards. A narrative explanation of hardship should be provided where a standard cannot be reasonably met.
- ✓ Documentation of watershed location, receiving waterbody name, and any known water quality impairments (see the state or territory Integrated Waters Report or 303(d) list). Consider prohibiting new unpaved roads where receiving waters are impaired for turbidity.
- ✓ Grading plan, road profile, and typical cross sections that clearly depict slope, pitch, drainage controls (temporary and permanent), and outlets, as well as distance to adjacent waterbody, stream, or wetland (if any).



- ☑ Drainage area map and drainage calculations (as needed) to confirm proper sizing of cross-drains, culverts, ditches, and traps. If a proposed road or driveway tie-in will be contributing draining to an existing road, an infrastructure analysis is needed to prove that there is sufficient capacity to accommodate flows.
- ☑ Temporary erosion and sediment control plan with stabilization schedule and staging areas.
- ☑ Annual maintenance plan and schedule for first 5 years of O&M and corresponding map with information needed to ensure road surface shape and drainage controls are maintained.
- ☑ Signed maintenance agreement (for private roads and shared, multi-owner roads) that identifies owner(s) and proposed maintenance contractor.

Permitting staff should visit the site to confirm existing conditions and proposed discharge locations, specifically connections to public roads, condition of downhill drainage infrastructure, or where discharges to receiving waters are proposed.

Enforcement staff should attend a pre-construction meeting with contractor to ensure proper clearing and grading of road. Site inspections should be conducted during construction to ensure proper grading and compaction of road surface; installation of drainage controls; and stabilization of slopes, ditches, and outlets. Site inspections conducted after rain events should include an assessment of discharge points and potential impacts to the receiving waters.

Final project closeout should not be signed off on until the site has been efficiently stabilized; a certification from the designer or contractor has been issued, and an as-built survey (or red-line markup of design plans) has been submitted. If there were substantial changes made during construction, the owner will need to revise and resubmit the maintenance plan.

The permit number, drainage control information, and maintenance schedule should be added to the unpaved roads database.



Pre-construction meetings with contractor could help prevent the sidestepping of loose (and erodible) cut material down the outside slope if proper disposal or cut/fill balance is discussed in advance.



Box 5. How to Better Manage Driveway Runoff

BEFORE

Driveway Runoff To Public Road

COMMON PRACTICE:



AFTER

Driveway Runoff Disconnected/Managed

BROAD-BASED DIP

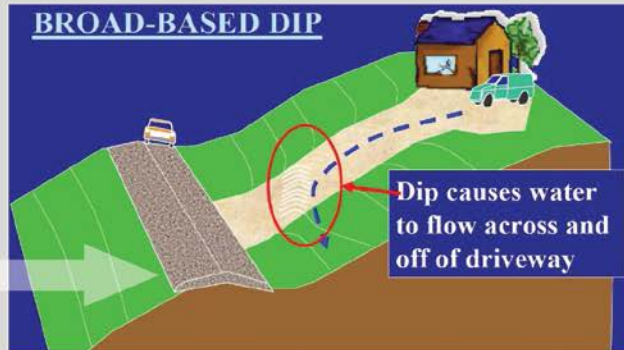

Program Funding

Programmatic and capital costs of an unpaved roads program can be funded through a variety of mechanisms. In fact, some of the program elements discussed previously may already fall within existing municipal program budgets.

Additional programmatic costs may include general administration and staff effort required to conduct the mapping inventory and assessment, database management, permit review, site inspections, and maintenance planning. A larger capital budget may be needed to implement a more aggressive road improvement program. Construction budgets will need to account for labor and materials, as well as equipment purchases and upkeep. There are a number of funding mechanisms to consider:



Over \$2M in federal grants were awarded for unpaved road drainage improvements to reduce sediment loading into Lao Lao Bay, CNMI.

- ✓ **Permit fees**—to generate funds needed to support permit review, site inspections, and enforcement.
- ✓ **Stormwater utility fees**—if you are lucky enough to have these, can be used for drainage infrastructure maintenance (ditch cleaning) and water quality improvements.
- ✓ **Homeowner association dues**—membership dues used to fund annual maintenance of shared road network.
- ✓ **Fines and penalties**—to support repairs, additional inspections and enforcement needs, and general program administration.
- ✓ **Performance bonds**—collected from developer prior to construction to cover road stabilization and drainage repairs if the owner is unable or unwilling to do so.
- ✓ **Taxes**—a portion of local taxes may go into a general fund to support capital expenditures probably already goes towards public infrastructure and road improvement projects.
- ✓ **Betterment loan**—municipality makes improvements on private road and charges private owner small annual fee through property tax bill to cover costs over 5-10 yrs (fee transfers with sale of property).
- ✓ **Grants**—use federal or state/territorial water quality or transportation grants to directly fund municipal road repair and maintenance projects. Grants may also be used to support cost-share or subsidy programs as incentives for private landowners. Look at opportunities for coastal resiliency and hazard mitigation funding.

Education and Training

No program is complete without some form of targeted education for local leaders, municipal staff, developers, construction contractors and equipment operators, and the general public. Unpaved road education should provide information on the impacts of unpaved roads on the environment and local infrastructure, how road improvements and proper design can alleviate frequent maintenance issues, and guidance on diagnosing and fixing existing road problems.

Educational elements to consider as part of a roads program include:

- ✔ Public messaging through newspaper and local social media outlets, on why unpaved road management is a win/win for the community. Messaging should be timed with recent flooding, high visibility erosion problems, or with environmental awareness campaigns. It is important to build public awareness prior to local officials being asked to support regulations, allocate capital budgets, or make changes in municipal policies regarding roads.
- ✔ Annual training for permitting, enforcement, and maintenance staff (can be open to contractors and homeowners) on road drainage design, diagnosing and fixing erosion issues, and general maintenance requirements. This training can be linked with field demonstrations.
- ✔ Contractor certification and equipment operator training on proper road grading, ditch construction, and maintenance. This training can be linked with scheduled road maintenance activities.



It is common for development projects to have long-term construction delays. Performance bonds provide funds to stabilize “temporary” roads that otherwise could erode unchecked for years.



Combining trainings with actual road maintenance or repair work is efficient and effective.

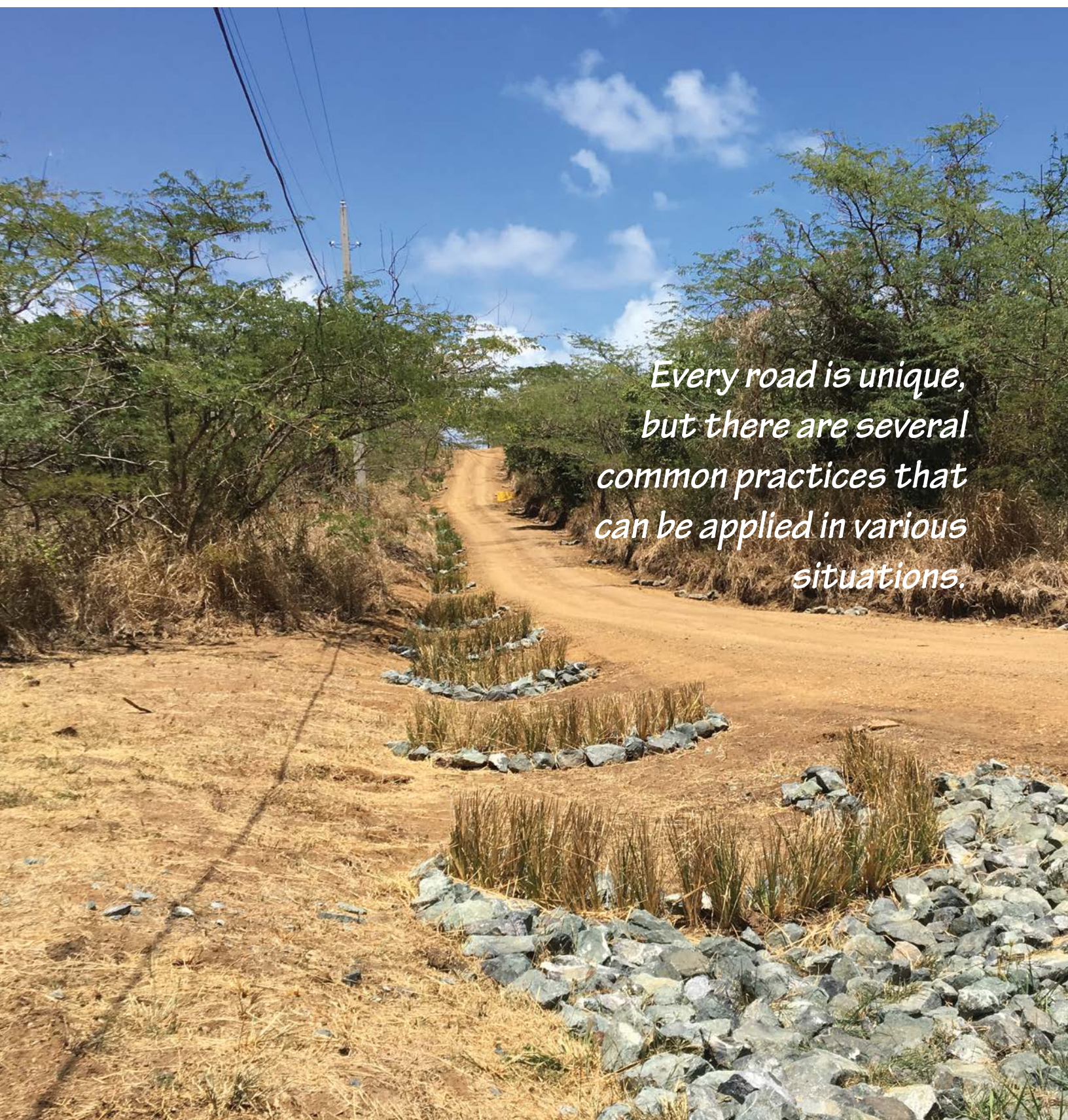

Part 4: Drainage Control Practices

A dirt road winding through a dry, hilly landscape with sparse green trees and dry grass. The road is bordered by several rows of grey rocks, each containing clumps of tall, dry grasses, which serve as drainage control practices. The sky is blue with scattered white clouds. A utility pole with power lines is visible on the left side of the road.

*Every road is unique,
but there are several
common practices that
can be applied in various
situations.*

Practice Fact Sheets

Fact sheets are provided on the following common drainage control techniques:

1. Grade Breaks
2. Dips and Low Water Crossings
3. Waterbars
4. Cross-drains & Culverts
5. Ditches
6. Turnouts
7. Sediment Traps
8. Geosynthetics
9. Soil/Aggregate Stabilization
10. Slope Stabilization

These fact sheets are meant to be concise and to serve only as reference guides for users. Each fact sheet includes a general description and photos of the control practice, including information on function and in what situation it is most applicably used. Bulleted lists of key design criteria and tips for installation & maintenance are also provided, as well as additional photos and schematic details to better illustrate the practice.

This list of practices and the information provided, of course, is not comprehensive. It covers the most common practices we have seen used for unpaved roads in the islands, but does not include many practices used heavily in other parts of the US, such as various subsurface flow diversions and perennial stream crossings (e.g., underdrains, French drains/mattresses bridges, or bottomless culverts). See reference material to access more information on these (and other) practices.

Dips & Low Water Crossings

Description
A wide, shallow reinforced depression designed to intercept water flowing down the road surface and ditch and transfer to a stable outlet. Broad-based and rolling dips are similar design variants that combine dips with berms in the travel lanes constructed below the reinforced dip. Dips used to convey intermittent stream (or ghat) flows that bisect the road are called low water crossings (LWC). Variations on LWC design may include narrower swales, but it is the width and gentle side slopes of the dips that allow for vehicles to pass without jarring without compromising the amount of flow that can be effectively managed.

Design

- Requires a wide depression, sometimes combined with a berm on the downhill road surface.
- Sizing will vary depending on road slope and traffic volume. Dips on flat roads may be relatively small (fill transitions as short as 12 ft and as low as 6 in). Dips on steeper roads will require more "approach fill" (fill transitions >100 ft long and up to 18 in deep).
- Fully extend to both edges of road. Skew at 20-40-degree angle to road in order to promote self-flushing.
- Reinforce bottom of dip with 3-4" stone, geogrid, or concrete.
- Outlet must be unobstructed and contain an energy dissipater or flow dispersion mechanism (coarse stone, plunge pool, level spreader, etc).
- Elevation drop towards outlet end of 2-3%.
- Spacing of multiple dips based on slope:

Road grade (percent)	Distance (feet)
2 - 4	300 - 200
5 - 7	180 - 160
8 - 10	150 - 140



Application

- Low traffic roadways
- Retrofit
- New road
- <10-12% road grade
- Low points such as surface stream crossings
- Replace cross drains

Construction

- Ensure proper size, since often made too small.
- Make sure intended flow channel, cross-slope, and side slopes to roads are as designed.
- If earthen, make sure berm and bottom are compacted properly with vibratory roller or tamper.
- Where paved, pour in two sections to maintain vehicular access.
- Check energy dissipater performance.

Maintenance

- Should function for years with little maintenance.
- Grade operators need to maintain dips during maintenance (slopes, transition berms, etc).
- Ensure interface between concrete lips and road surface are maintained.
- Remove any vegetation at outlet that may block discharge.
- Remove accumulated sediment within the dip and in the energy dissipater/outlet.

STANDARD CONSTRUCTION DETAIL #3-7
Broad-Based Dip for High Gradient (>5%) Roadways

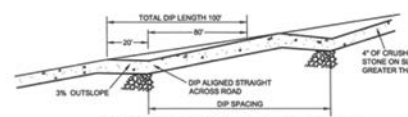

(Source: PA Department of Environmental Protection)

Fact sheets include description and photos; tips on design, construction, and maintenance; and typical details, where available.

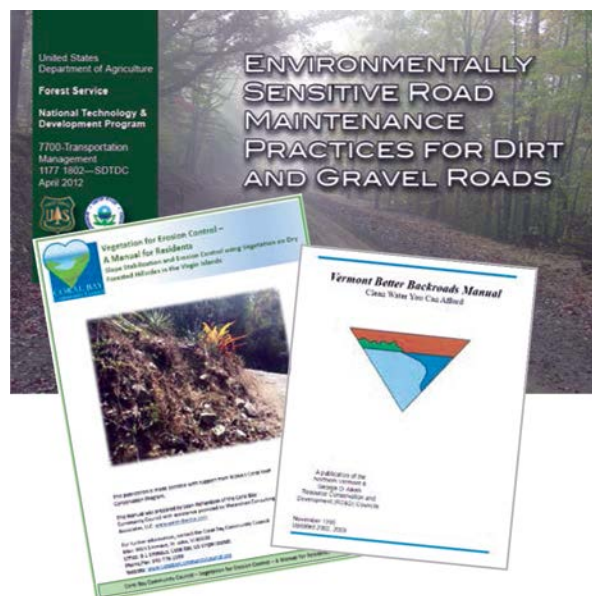

Reference materials used in development of fact sheets provide more detailed information on these (and other) practices.

Grade Breaks

Description

Intentional grade interruption on a downhill slope that creates undulations that redirect flows off of the road surface to one or both sides into ditches or dispersal areas. Their purpose is to prevent build up of water volume and velocity in the travel lanes, even where road crown or pitch has been lost. Breaks shed water to the shoulders and are not intended carry concentrated flow. If properly executed, breaks can help reduce the number of other drainage control practices needed. They are an inexpensive measure to reduce and prevent erosion of unpaved roads.



Design

- Grade breaks should be incorporated during the early stages of road design so they can be created during initial road construction.
- Should be big enough to shed water, but gentle enough to allow traffic passage
- Space as needed based on slope. Roads should be less than 10% slope. Steeper slopes require breaks to be constructed closer together.
- Use longer transitions on steeper slopes to tie grade break into existing road elevation.
- Use in conjunction with cross-drains to divert flows into pipe inlets and to provide needed pipe cover.

Application

- Low volume/speed roads
- At grade transitions
- Gentle to moderately sloping road sections
- Infrequently maintained roads
- Before stream crossings
- With cross-drains

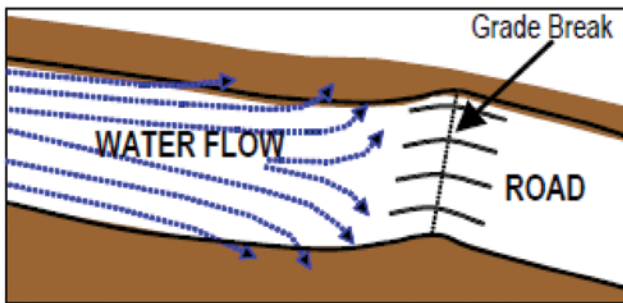

Construction

- Easy to install with commonly-used machinery—a bulldozer is preferred but can be constructed with a grader.
- Could require 40 to 60 tons of material to create transitions into and out of grade break (more on steeper slopes)
- Taper edges of grade break back into road grade. Test structure by driving across it. If you bottom out, the break grade is not subtle enough.

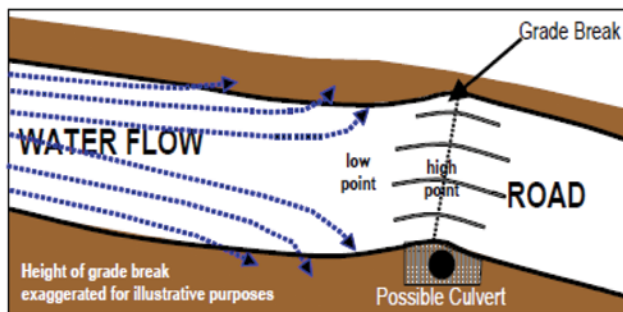

(Graphics: Center for Dirt and Gravel Road Studies)

Maintenance

- Relatively maintenance free.
- Consider installing signage to alert maintenance crews where grade break is located.
- Instruct operators not to use grade break as source of material to smooth other road deformities.



Dips & Low Water Crossings

Description

A wide, shallow reinforced depression designed to intercept water flowing down the road surface and ditch and transfer to a stable outlet. Broad-based and rolling dips are similar design variants that combine dips with berms in the travel lanes constructed below the reinforced dip. Dips used to convey intermittent stream (or ghut) flows that bisect the road are called low water crossings (LWC). Variations on LWC design may include narrower swales, but it is the width and gentle side slopes of the dips that allow for vehicles to pass without jarring without compromising the amount of flow that can be effectively managed.



Design

- Requires a wide depression, sometimes combined with a berm on the downhill road surface.
- Sizing will vary depending on road slope and traffic volume. Dips on flat roads may be relatively small (fill transitions as short as 12 ft and as low as 6 in). Dips on steeper roads will require more “approach fill” (fill transitions >100 ft long and up to 18 in deep).
- Fully extend to both edges of road. Skew at 20-40-degree angle to road in order to promote self-flushing.
- Reinforce bottom of dip with 3-4” stone, geogrid, or concrete.
- Outlet must be unobstructed and contain an energy dissipater or flow dispersion mechanism (coarse stone, plunge pool, level spreader, etc).
- Elevation drop towards outlet end of 2- 3%.
- Spacing of multiple dips based on slope:

Road grade (percent)	Distance (feet)
2 - 4	300 - 200
5 - 7	180 - 160
8 - 10	150 - 140

Application

- Retrofit
- New road
- <10-12% road grade
- Low traffic roadways
- Low points such as surface stream crossings
- Replace cross drains

Construction

- Ensure proper size, since often made too small.
- Make sure intended flow channel, cross- slope, and side slopes to roads are as designed.
- If earthen, make sure berm and bottom are compacted properly with vibratory roller or tamper.
- Where paved, pour in two sections to maintain vehicular access.
- Check energy dissipater performance.

Maintenance

- Should function for years with little maintenance.
- Grade operators need to maintain dips during maintenance (slopes, transition berms, etc).
- Ensure interface between concrete lips and road surface are maintained.
- Remove any vegetation at outlet that may block discharge.
- Remove accumulated sediment within the dip and in the energy dissipater/outlet.

STANDARD CONSTRUCTION DETAIL #3-7
Broad-Based Dip for High Gradient (>5%) Roadways

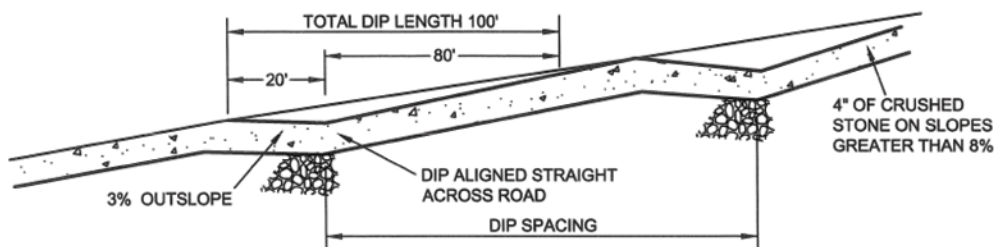

(Source: PA Department of Environmental Protection)



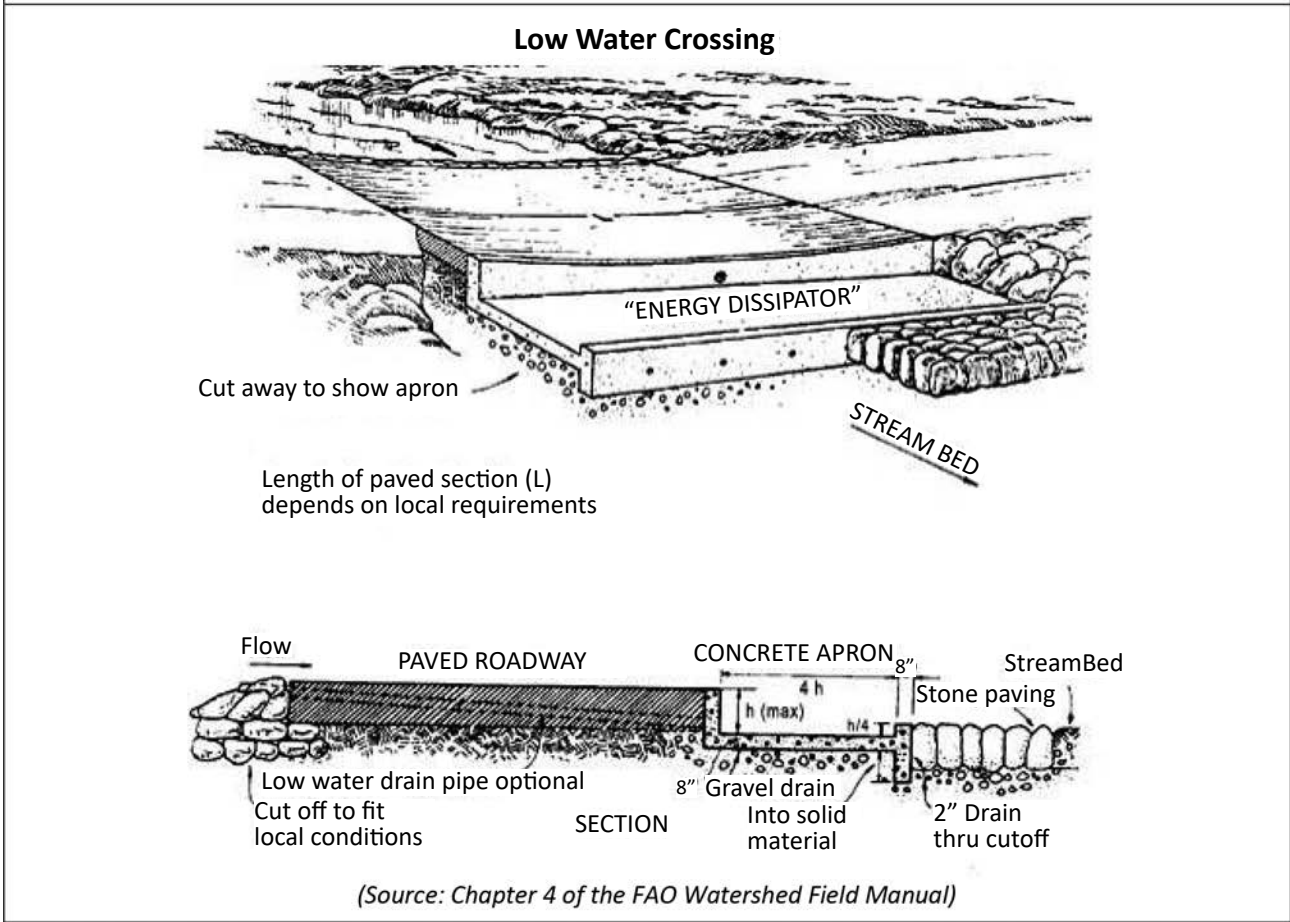
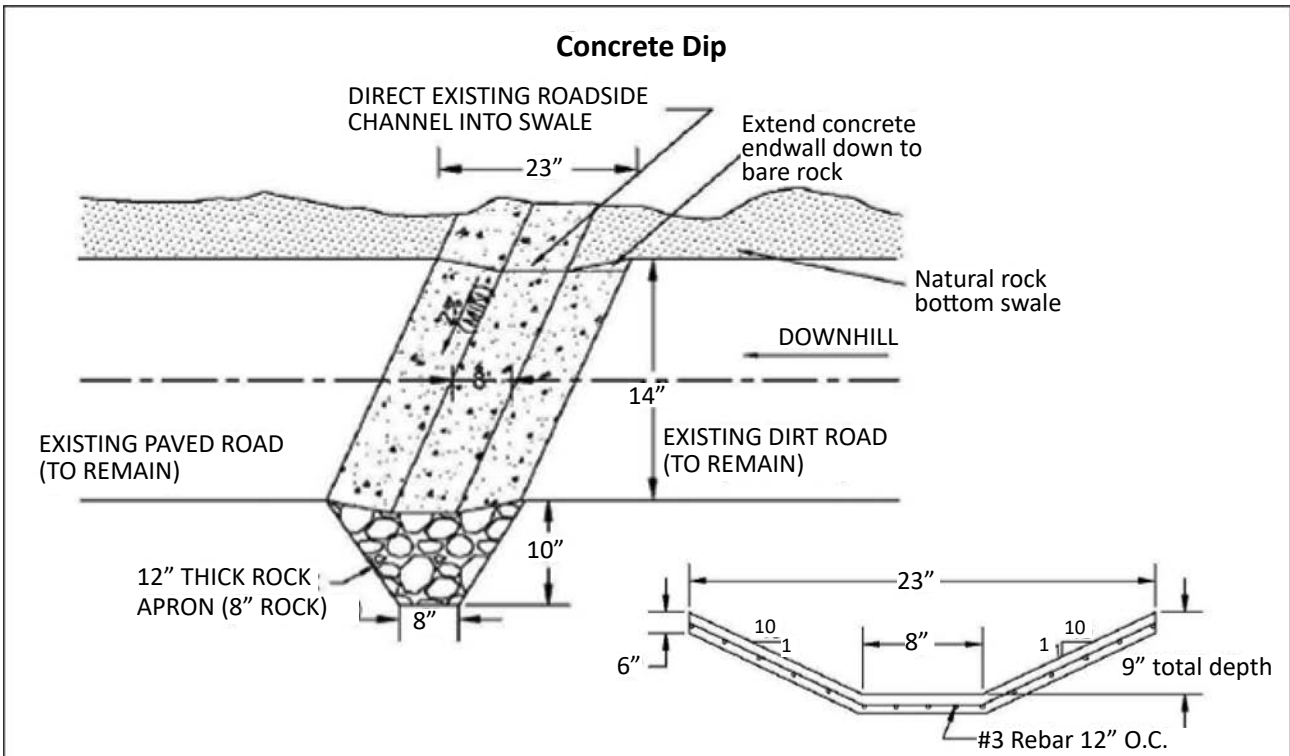

Broad-based Dip

(Source: Technical Bulletin, Center for Dirt & Gravel Roads Studies, 2008)

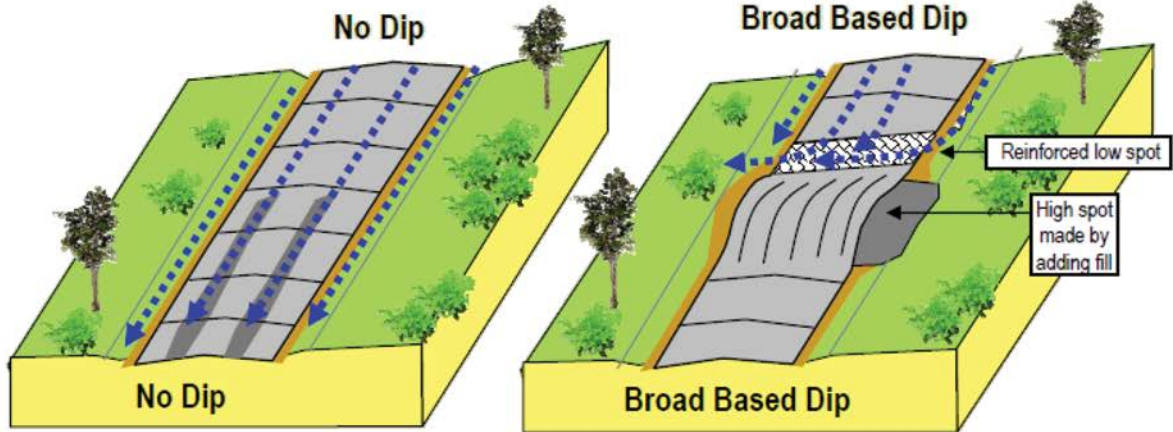

Water is allowed to run down the roadway and ditch. This builds volume and velocity which can erode the road area and deliver sediment to streams.

The *Broad Based Dip* forces water flowing on the roadway and in the ditches to a stable outlet area to reduce erosion. Reinforcement of the outlet area may be needed, depending on site conditions.

BROAD-BASED DIP (longer, flatter) & ROLLING DIP (shorter, steeper)

(Source: Texas A&M Forest Service, 2013)

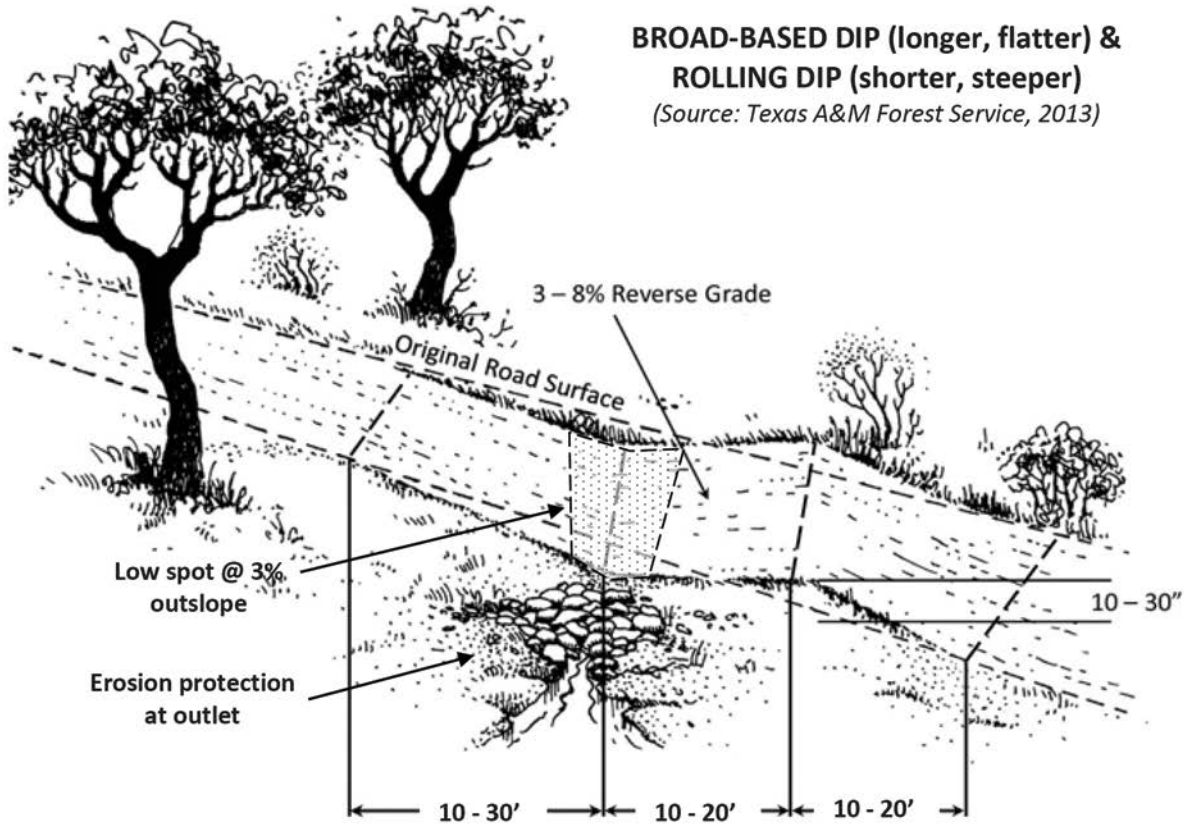



Construction of concrete dip in two pours to allow vehicular access during construction.



Stones embedded in concrete low-water crossing to improve vehicle traction during wet weather.



Use of concrete block dip at low point as a cost and more "pervious" alternative to concrete



Rock reinforced broad-based dips are easily traversed by cars. Notice no ditch interception here, so concrete not necessary.



Dip intersects ditch (left side of photo) and discharges downslope (on the right). If not pitched enough or if outlet blocked by vegetation, dip can fill with sediment.



Outlet should be stabilized and include a level spreader (as shown here) or energy dissipator to slow and spread discharged flows.



Waterbars

Description

Narrow berms installed diagonally across the road to reduce the amount of time and distance runoff travels on the road surface. Waterbars intercept shallow flows from the road surface and direct them towards an outlet structure on one side of the road (typically outsloping). They are not intended to intercept concentrated flows from ditches (see cross-drains). Waterbars typically consist of a ridge and channel made of earth, concrete, timber (e.g., telephone poles), or other materials. They can be shallow or deep depending on flow volume and traffic requirements. There are a number of design variants to choose from based on constructability, maintenance, and drivability objectives.



Design

- Requires a raised berm and associated channel typically 3-4 ft wide (depending on material and flow).
- The berm should be on the downhill side of the water bar, with a crest 6"-12" above grade.
- Maintain 1-2 ft vertical distance between berm crest and channel invert.
- Skew waterbar at 30-45 degree angle across road in order to promote self-flushing and improve drivability.
- Provide turn-out. Outlet must be unobstructed and protect against erosion (use coarse rock).

Road Grade (%)	Waterbar Spacing (Ft)
2	250
5	135
10	80
15	60
20	45

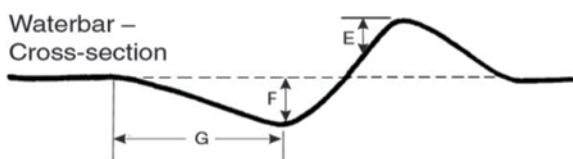
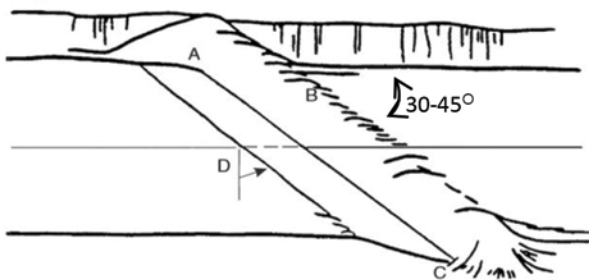

(Source: FAO Conservation Guide #13)

Application

- Retrofit
- New road
- <20% road grade
- Low speed roads
- In conjunction with paved & unpaved transitions

Construction

- Start at top of hill. Construct low enough to allow traffic to pass, but high enough to intercept flow
- Ensure both ends are tied into edges of road.
- Be sure to confirm proper installation angle.
- If earthen, make sure berm is well compacted
- Where paved, pour in two sections to provide temporary vehicular access.

Maintenance

- Can require a lot of maintenance to keep berm shaped (if earthen) and to remove accumulated sediment.
- Grade operators need to maintain earthen berms during maintenance.
- Ensure interface between concrete lip and road surface is maintained.
- Remove any vegetative berms at outlet location that may prevent discharge.



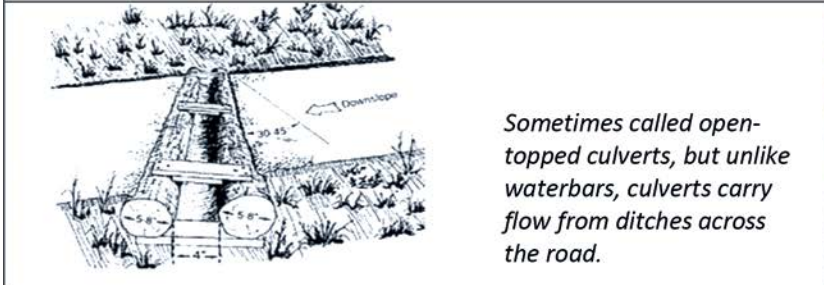
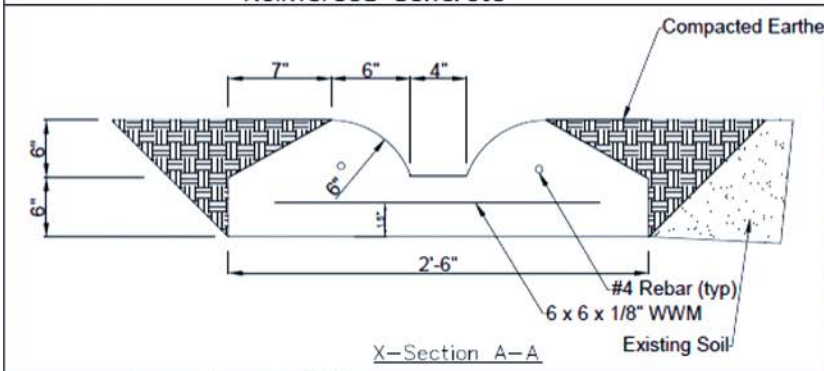
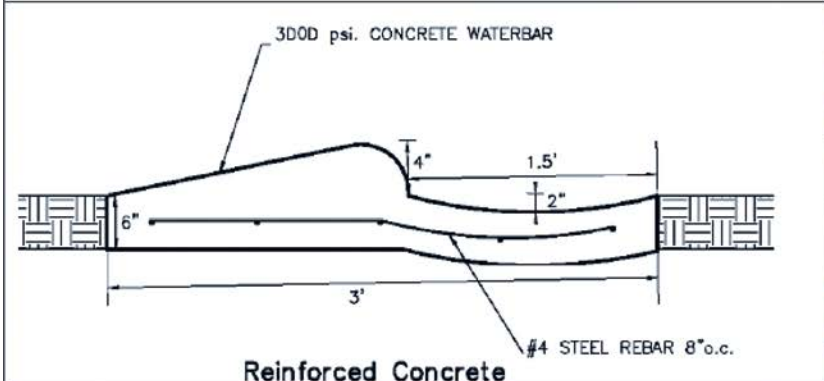
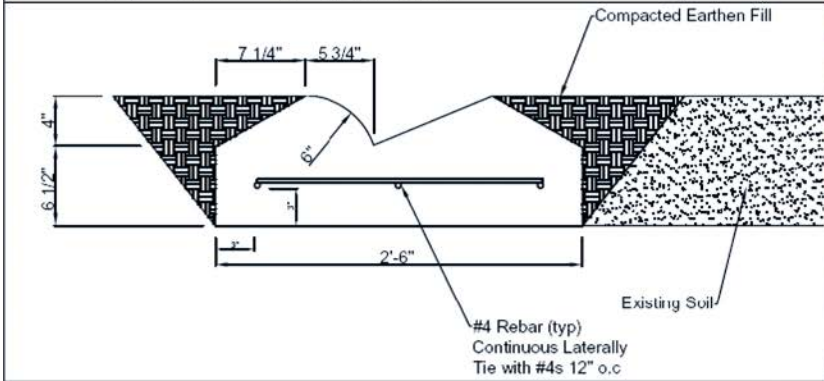
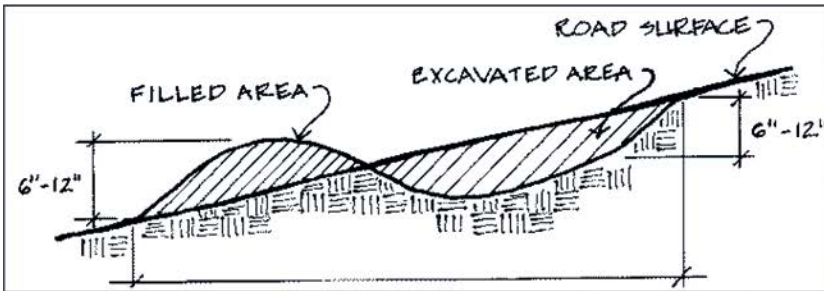

Sometimes called open-topped culverts, but unlike waterbars, culverts carry flow from ditches across the road.



Cross-drains & Culverts

Description

Cross-drains (aka cross-pipes, ditch relief drains, and culverts) are pipes, or open-topped structures used to transfer flows from ditches to the other side of a road. Cross-drains are needed at regular intervals to prevent ditches from overflowing. Cross-drains serving as ditch relief have an angled installation to be more in line with ditch flows. Pipes connecting ditches beneath a driveway or tie-in road are typically called road culverts. Pipes used to convey stream flows under a road are generally referred to as stream culverts and are not included here.



Design

- Culvert pipe sizing is based on drainage area, anticipated rainfall, soils, and slope. See regional sizing calculations. Recommend a minimum 18" pipe diameter (larger needed if drainage area is >2 acres).
- Elevation to be set at outlet based on natural ground elevation. This may require fill to be placed above pipe to meet cover requirements, rather than digging deeper for pipe installation.
- Angle pipe best alignment with ditch direction (at least 30-45 degrees across road).
- Pitch on pipe needs to have minimum 1-2% slope.
- Cover requirements based on pipe and road material. Rule of thumb is at least 1 ft of cover or 1/2 pipe diameter. Plastic pipes should have 1.5 ft of cover.
- Cross-drains should discharge away from streams whenever possible to keep sediment-laden road runoff away from the watercourse.
- Stable outlet to include rock aprons, plunge pool, etc. to slow flow, control erosion at outlet and filter sediment. Consider combination of rock and vegetation.
- Consider necessity for headwalls and/or end walls based on culvert location.
- Space as frequently as possible to reduce time of water on road and velocities/volumes in ditches.

<u>Road Grade (%)</u>	<u>Cross-drain/Culvert Spacing (Ft)</u>
2	135
5	100
10	80
15	60
20	45

Application

- Roads with ditches
- Not for streams
- New road
- Retrofit
- Driveways and intersections

Construction

- Excavate trench to lay pipe. Make sure bed is rock-free. The bottom width of the culvert trench should be twice the width of the culvert with sidewalls no steeper than 1:1.
- Make sure inlet pipe invert is at same elevation as ditch bottom and that outlet side invert is at ground elevation.
- Base and sidewall fill material should be compacted. Tamp backfill at regular intervals. 8-in maximum lifts.
- Armor both entry and exit of pipe with rock, consider installation of headwall structures to prevent erosion.
- May need to install a ditch block (berm or check dam downstream of cross-drain inlet) to force ditch flow into cross-drain. Make sure overflow can continue down ditch rather than flooding road.
- For open top culverts, ensure opening is at least 6" wide to allow a shovel access for sediment removal.

Maintenance

- Can require a lot of maintenance to keep from clogging. Take an inventory of culvert locations to used for maintenance checks.
- Remove debris, sediment, and vegetation from entry and outlet areas to maintain positive drainage.
- If end of pipes are damaged or erosion is occurring near pipes, consider installation of a headwall.
- If cross-drain is improperly angled or sized too small, this could lead to ditch bank erosion around pipe inlet and outlet. Realignment may be needed.
- Check for piping, sinkholes, and joint separation. Replace undersized pipes.



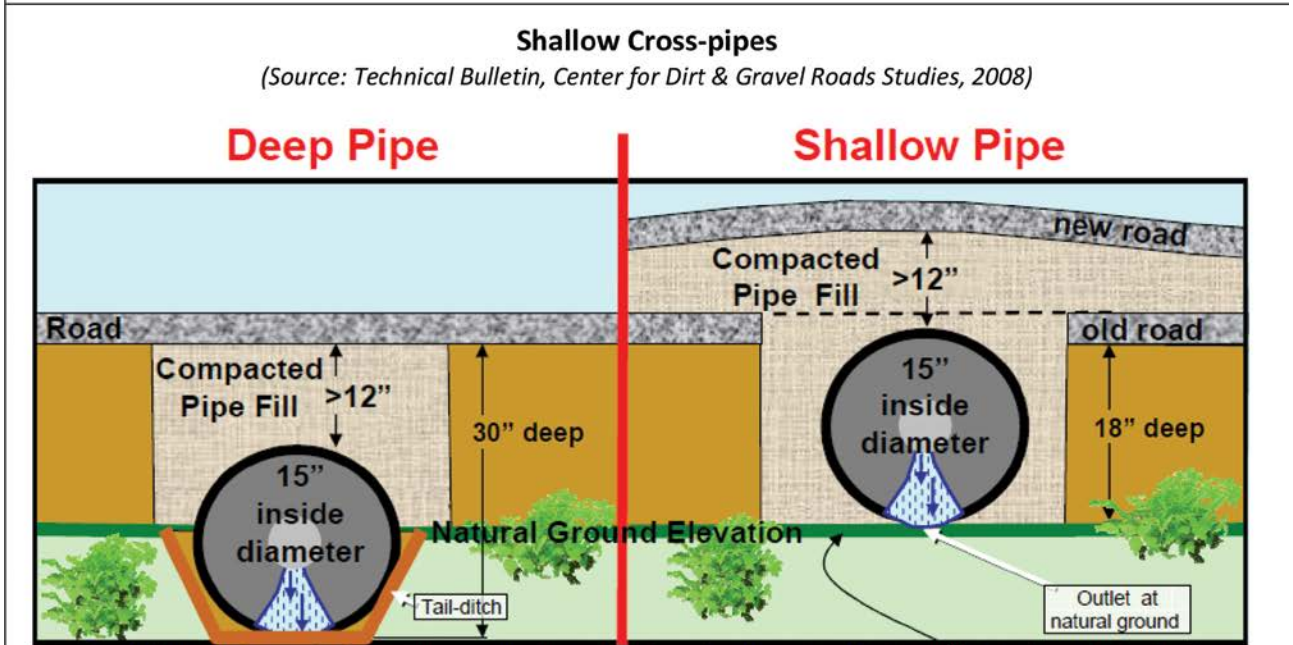
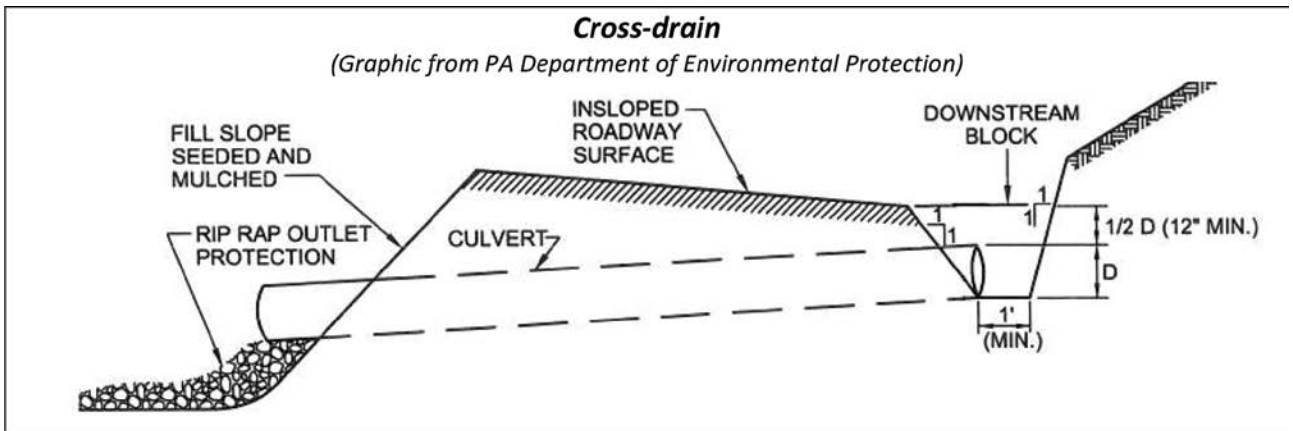

Side View, looking through crosspipe from outlet, comparing deep and shallow pipe placements. Note the green “natural ground elevation” line. Deep pipes dig down to obtain pipe cover. Shallow pipe placements are based off the natural ground elevation, and use fill to achieve pipe cover.



Cross-pipe installation trench should be deep enough to match ditch invert and natural ground level.



Consider adding compacted fill on top to provide sufficient cover. This could become a grade break.

Outlet Protection

(Source: VT Unpaved Road BMP Manual)

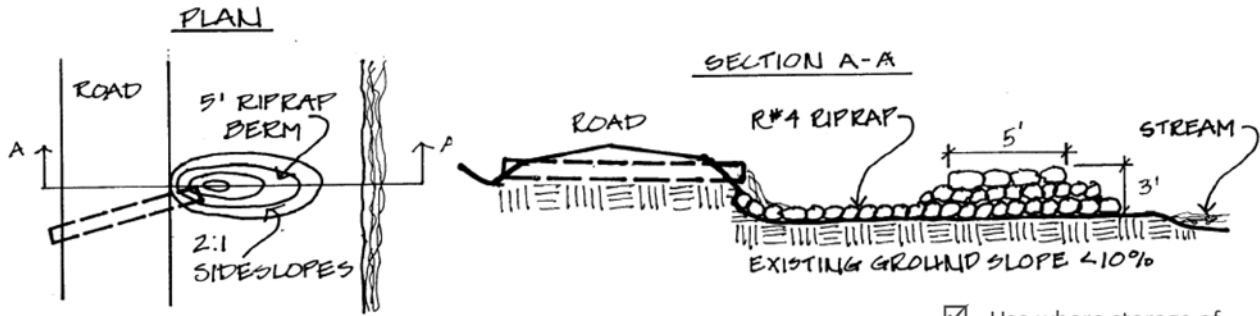

Plunge Pool

- Use where storage of runoff is needed

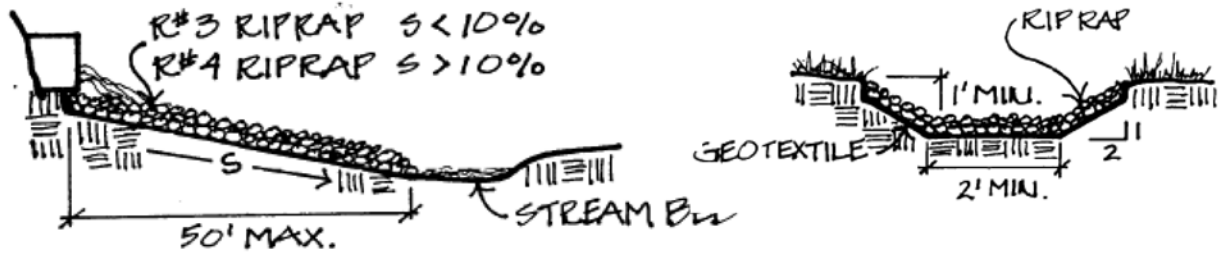

Rip Rap Channel

- Use on fill slopes, steep slopes where outlet flows close to surface waters.

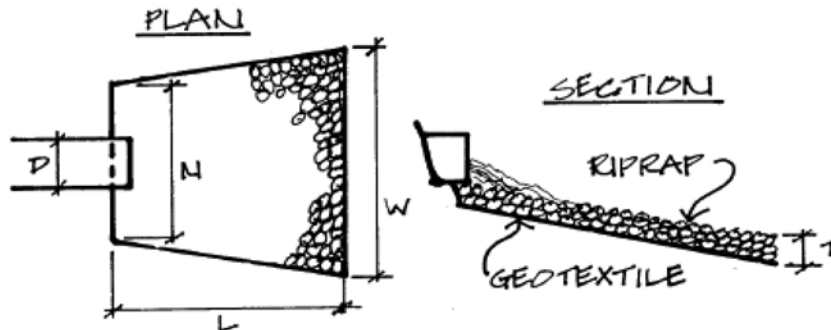

Rock Apron

- Use where there is an adequate filter strip between outlet and waterbody.



Level Spreader

- Changes concentrated flow to sheet flow.





Lack of outlet protection at this newly installed cross-drain leads to erosion of slope at pipe exit.



This cross-drain outlet has a stone plunge pool with vetiver grass incorporated into the berm.



Design variant of a rock channel outlet using combination of rock and vetiver rows to dissipate flows.



Probably overkill for short road segment outlets, but more formal energy dissipation for higher volume flows is an option.



Use headwalls and endwalls (with or without wings) to protect pipe edges from damage and banks from erosion.





Use of headwalls for cross-drains on Culebra, Puerto Rico to increase visibility and stability around pipe inlets. The headwall helps to funnel flow into pipe. An overflow orifice is provided in case inlet becomes clogged.



Rock aprons at outlet pipes are good if you have a level area where flow can be dissipated into a vegetated buffer.



Outlets without stabilization can lead to erosion and headcutting.



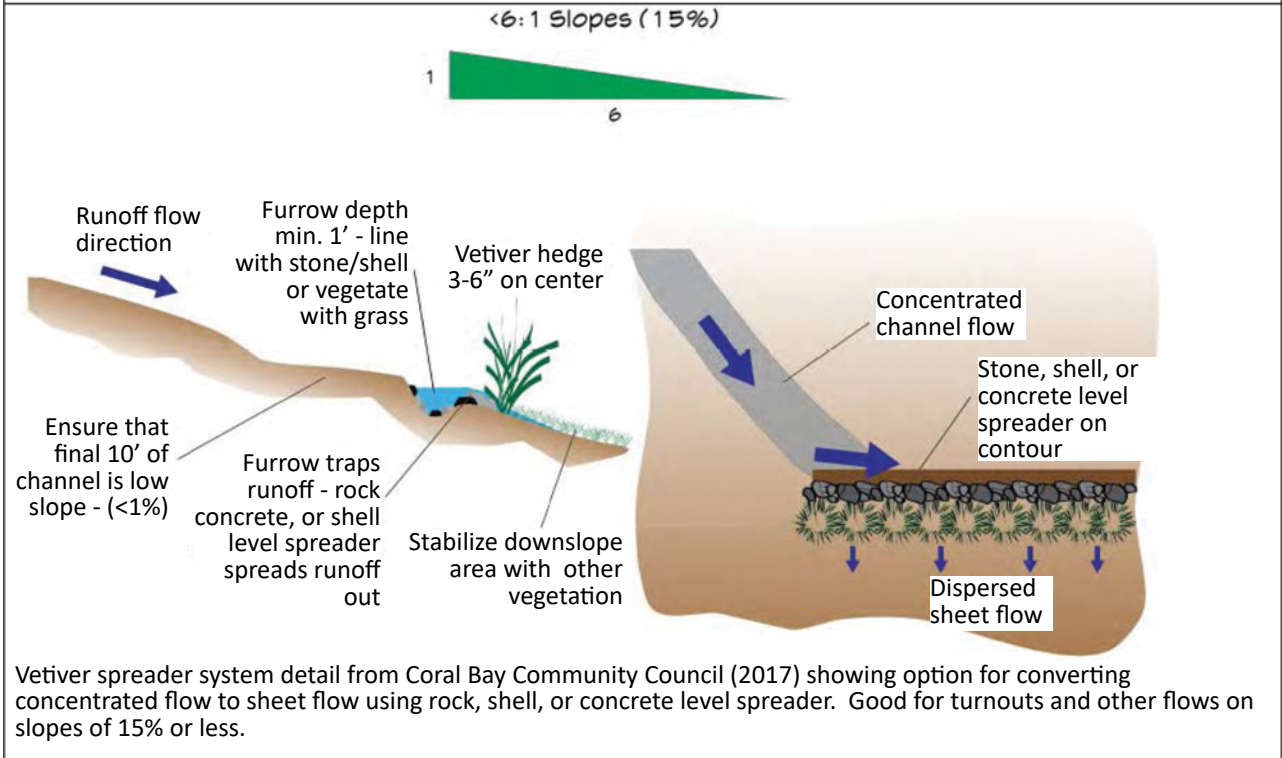
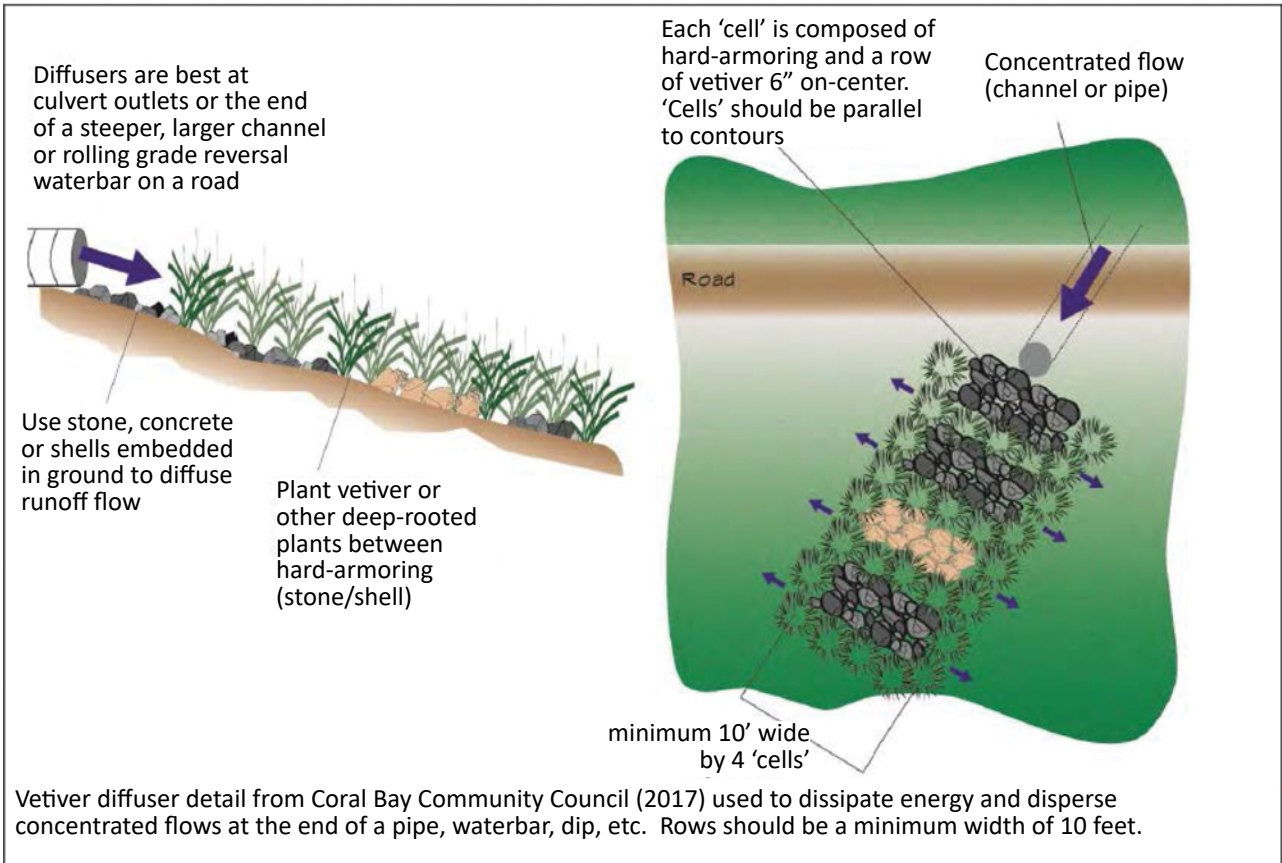

Ditches

Description

Roadway ditches collect and convey road runoff, cutbank seeps, and off-site “run-on” to adequate outlets without causing erosion. Using ditches is not ideal and should be avoided if practical (i.e., use outsloped or crowned profiles). Ditch location, profile, shape, lining, and number of outlets effect how efficiently water will be removed from the roadway. Ideally ditches should resist erosion, be self cleaning, and discharge onto nearly level vegetated areas. Energy dissipating devices to reduce velocity and turbulence in ditches are often necessary. If constructed properly, ditches will remove runoff quickly and reduce seepage into the road subgrade.



Design

- Locate ditches on the up slope side of the road to prevent water from flowing onto the road from uphill.
- Design and grade ditch and bank side slopes at a maximum 2H: 1V ratio.
- Excavate a ditch deep enough to drain the road base, generally 1.5 to 2 feet deep. Consider impracticalities of using ditches where bedrock is close to surface and excavation of ditches challenging.
- Low maintenance ditches have wide (at least 2 ft), shallow, parabolic-shaped (not v-shaped).
- The size of ditch is dependent on the volume of water it must manage. More frequent ditch outlets reduce the need for large ditches. Should convey the 10-yr storm safely (non-erosively).
- Maximize the number of ditch outlets to disperse road runoff.
- Disconnect ditches prior to stream crossings through re-profiling (i.e., redirect with berms to vegetated filters). Avoid direct discharge of concentrated flow into waterways.
- Vegetate ditches that have < 5% slope with grass in order to filter sediments. Use check dams or line ditches that have >5% slope with rock. Combinations of rock and vetiver grass have been successfully demonstrated in Puerto Rico.

Ditch Lining		
Channel Slope	Lining Material	Lining Thickness
0-5%	Erosion control blanket and seeding	
5-10%	2-6 inch diameter rock	7.5"
> 10%	3-12 inch diameter rock	12"

(from MA Unpaved Road BMP Manual, 2001)

Application

- New road
- Insloped or crowned roads with ditches

Construction

- Excavate roadway ditches at a bottom elevation 1 to 2 feet below the road base. Use a backhoe bucket, which is the perfect shape for a wide, shallow ditch.
- Do not construct U-shaped ditches. U-shaped ditches have less drainage capacity than other shape, look messy, and have steep sides that cave in and make maintenance difficult.
- Line ditches as soon as possible to prevent erosion and to maintain the ditch profile.

Maintenance

- Perform regular maintenance to keep ditch clear and stable, and to maintain capacity of channel.
- Prevent water from standing in a ditch—standing water weakens roads.
- Cleaning ditches while grading often leads to deep, V-shaped ditches. Use different method or alternative equipment.
- In sensitive areas, clean or reshape ditches in sections, skipping every other section to allow unmaintained sections to serve as filters to trap sediment caused from maintenance activities.



Ditch Shapes

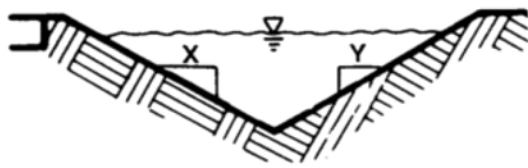

V-shaped, symmetrical



V-shaped, unsymmetrical



Trapezoidal



Bucket-shaped, parabolic (preferred)



Bedrock can make ditch excavation challenging.



Lined ditch combined with vetiver check dams, full of sediment.

Check Dams

(from Guam ESC Field Guide, 2017)

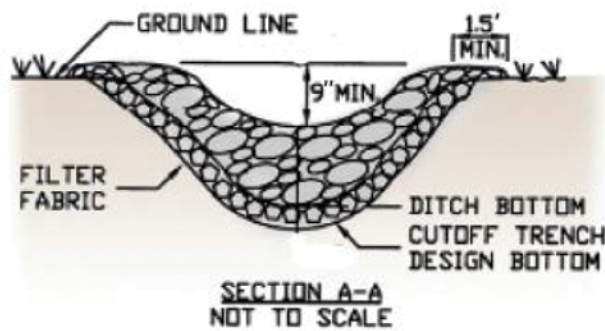
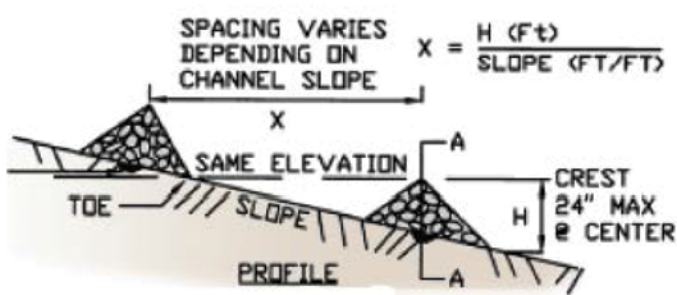

Check dams can be made of rock, sand bags, or other durable materials. They are installed across a ditch to reduce flow velocity, help with grade changes, and trap sediment.

- Max 2 acres draining to a check dam.
- Anchor with a cutoff trench lined with filter fabric.
- Use well-graded rock matrix of 2-9 inch rock.
- Height less than 2 ft with a center at least 9 inches below sides. Tie into banks. Side slopes 2:1 or flatter.
- Spacing based on slope with crest of lower check at same elevation with toe of uphill dam.

Road Grade (%)	Check Dam Spacing (Ft)
<2	80
2-4	40
5-7	25
8-10	15

- Maintenance includes removing accumulated sediment behind dam, replacing dislodged rock, fixing run-around erosion on ditch slopes.

Check dams are best used in channels (ditches). They can be vegetated only, or supplemented with hard-armorings (stones, shells, or concrete) for higher flows.

Plant double rows of vetiver (or similar) staggered and parallel to flow.

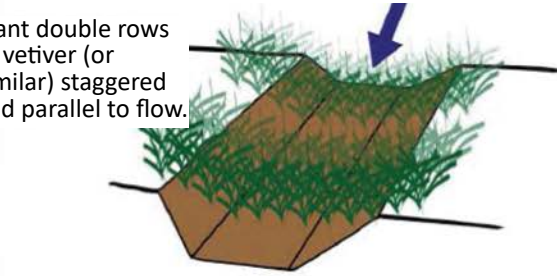

Use only plants for lower-flow channels.



Use hard-armorings for higher-flow areas.

Channel (ditch)

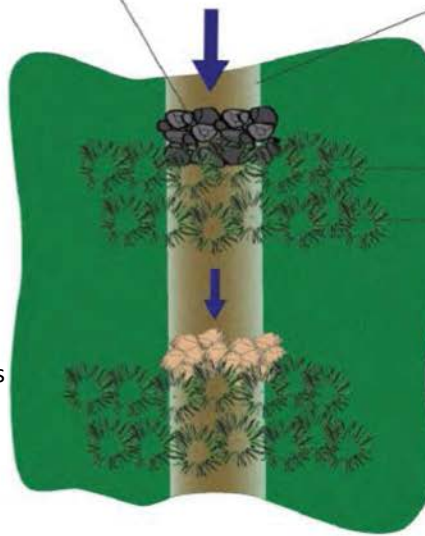

Rows 6" apart. Plants 5" on-center.

Extend hard-armorings across entire channel and up side-slopes in higher-flow conditions.



Vetiver check dam detail with armoring options for higher flow channels (from Coral Bay Community Council, 2017). The vetiver grass helps dissipate energy, trap sediment, and soak up standing water.



Example of recently planted vetiver-rock check dams leading to a sediment trap on Culebra, Puerto Rico.



Diversion Ditches

Also referred to as bank benches, interceptor swales, or diversion swales, a diversion ditch is installed above a road section to divert off-site runoff from adding flow to a road surface or roadside ditch. These diversions can be very effective and can compliment slope stabilization efforts.

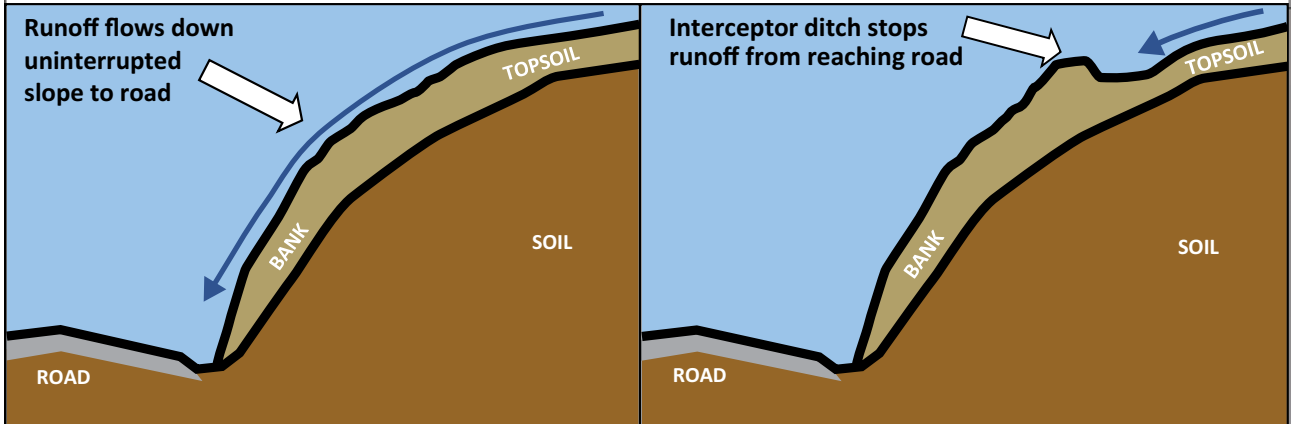

Additional flow coming from the hillside adds runoff onto the road.



Use of an interceptor ditch would be ideal to divert runoff away from the road surface.

Design guidance for bank benches from Center for Dirt Road Studies (2008) includes:

- A backhoe can be used from the road to build bench
- Slope needs to be sufficient to move water, but not to create erosive velocities
- 3:1 transition into bank with a width of 4-10 ft
- Stabilize with seed, mulch, or erosion control blanket as soon as possible. Use native vegetation.
- Outlets should be located in stable, flat, well vegetated area.

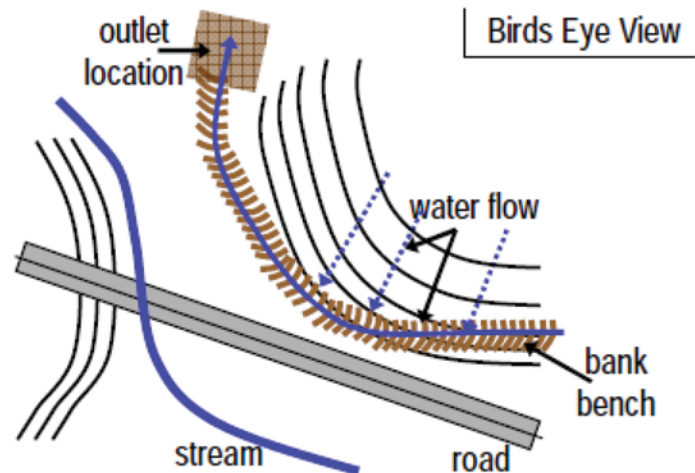

Turnouts

Description

Turnouts are extensions of ditches that direct water to filtering areas. Use only in areas where the water will flow positively in a filtering area well away from the road and adjacent surface waters. There must be adequate outlet protection at the end of the turnout area, either a structural (rock) or vegetative filtering area. See the section on culverts for outlet protection details.



Application

- Roads with ditches
- Associated with treatment practice or filter area

Design

- Do not make water turn at a right angle. It will not. Angle turnouts and incorporate berms on downhill side to minimize bypass.
- Space as frequently as possible to reduce time of water on road and velocities/volumes in ditches

Road Grade (%)	Turnout Spacing (Ft)
2	250
5	135
10	80
15	60
20	45

Construction

- Depends on material.
- Ensure stable surface of turnout and outlet (see outlet protection).

Maintenance

- Can require a lot of maintenance to keep vegetation, sediment, or debris from blocking outlet. This could lead to backup, road flooding and ditch erosion.
- If maintenance seems too frequent, consider options for adding more turnouts uphill.

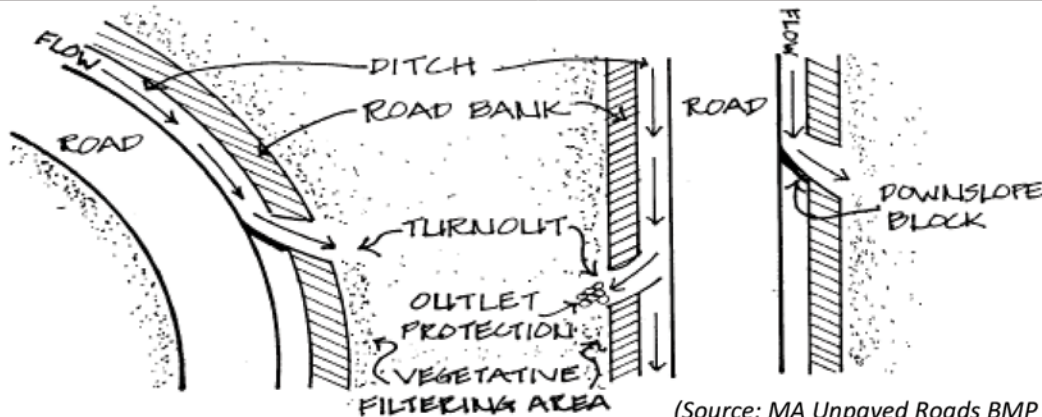

(Source: MA Unpaved Roads BMP Manual)



(Source: Alabama Forest Service)



Turnout to ponding basin is completely blocked with sediment



Sediment Traps

Description

A sediment trap is a temporary ponding area to hold runoff from small, disturbed areas or road segments. Traps detain water long enough for the majority of sediment to settle out of the water column. It is constructed by excavating a depression or by placing an earthen or rock embankment across a low area or drainage swale. An outlet or spillway allows for a slow, controlled release of runoff. While many traps are created as temporary erosion and sediment control devices during construction, they can be converted to permanent stormwater features for longer-term use as long as they are maintained.



Design

- Consult an engineer on proper sizing and outlet structure design.
- Should be sized to hold at least 1"-1.5" of rainfall over the total contributing drainage area, which is ~3,600 - 5,600 cf/acre. Remember that the contributing drainage area may include more than the road surface (side slopes, driveways, etc).
- The maximum drainage area is 5 acres.
- To lengthen settling time, a length to width ratio of >2:1 is recommended.
- Outlets elevations for riser, pipe, or spillway should be 1 ½ ft below top of dam. Earthen or rock dams should have a maximum height of 5 ft; minimum width of 4 ft, with 2:1 or flatter side slopes.
- Use vegetation where practical to stabilize side slopes. Grass can be used on dams and spillways, but not woody plants.
- Offline installation outside the ditch line is preferred (i.e., install below turnouts or cross-drains).

Application

- | | |
|--|---|
| <input checked="" type="checkbox"/> Retrofit | <input checked="" type="checkbox"/> Temporary erosion control |
| <input checked="" type="checkbox"/> New road | <input checked="" type="checkbox"/> Permanent treatment practice associated with turnouts and outlets |

Construction

- Use backhoe or small excavator for excavation. Be sure to minimize damage to surrounding trees.
- Compaction of earthen dam is very important.
- Be sure to extend rock dams fully across width of trap. Use anchor trench with separating geotextile.
- Spillway crest should be lower than top of dam.
- Stabilize outlets, side slopes, and inlets.

Maintenance

- Will require removal of accumulated sediment when capacity is reduced by 1/3rd original volume
- Inspect for erosion of side slopes, around dam, and downstream of spillway/outlet.
- Riser pipes may clog depending on perforation sizes and if filter fabric or rock filter used.

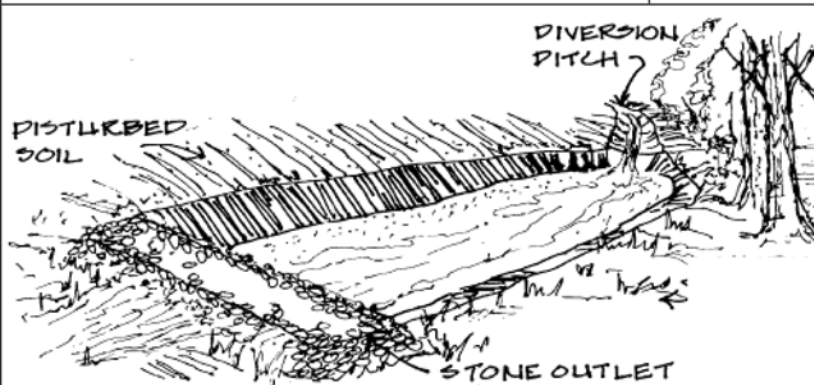

(Graphic from MA Unpaved Road BMP Guide)



Create a filter using smaller sized rock on the inside of rock dams.

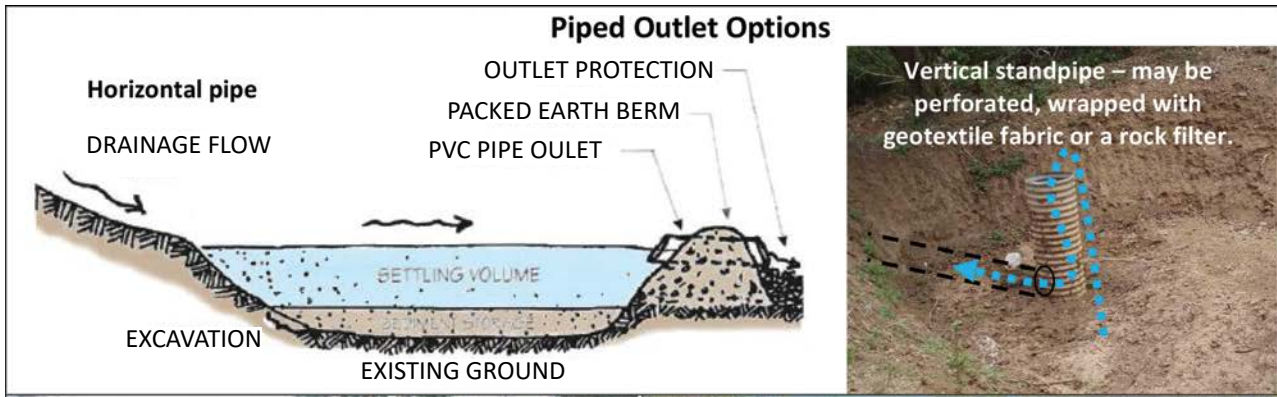

Proper compaction of dam/outlet berm with roller or hand held compactor is a critical step in construction.



Trap design variant with rock-line side slopes and overflow spillway with vetiver grass on bottom.



Traps built in-line with ditches can blow out with heavy rains due to lack of bypass alternatives.



Traps can become permanent drainage control features that provide water quality treatment prior to discharge.

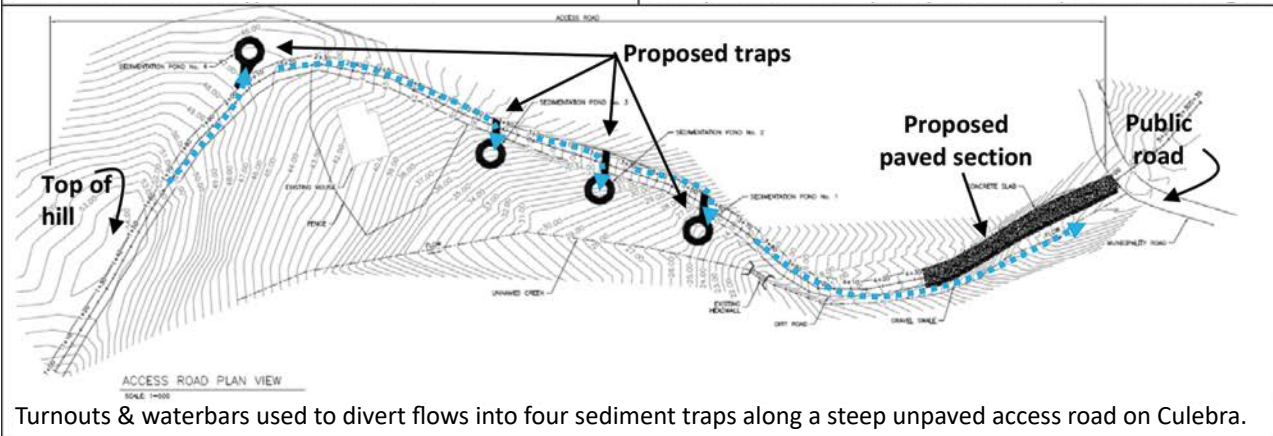

Turnouts & waterbars used to divert flows into four sediment traps along a steep unpaved access road on Culebra.

Geosynthetics

Description

Permeable synthetic fabrics, 2D grids, and 3D containment cells can be used to add strength to road surfaces, distribute vehicle loads, and reduce erosion. The strategic use of these materials can help eliminate soft spots, potholes, ruts, and other surface deformities. Separating subsoil layers with densely woven geotextile fabrics can prevent the upward migration of fines into surface layers. Highly flexible geogrids spread the weight of vehicles laterally, which reduces subgrade contact pressures. Geocells can provide structural support, hold surface materials together, and allow water passage.



Design

- There are many types and uses of geosynthetics. Manufacturers can help in selecting the correct material and design support for your specific need.
- Don't let the hassle of shipping deter you from using geosynthetics. They will need to be ordered from off-island, but most of these materials come in rolls and are relatively light compared to other construction materials. Use of geosynthetics is growing in popularity, thus they are becoming more easily available.

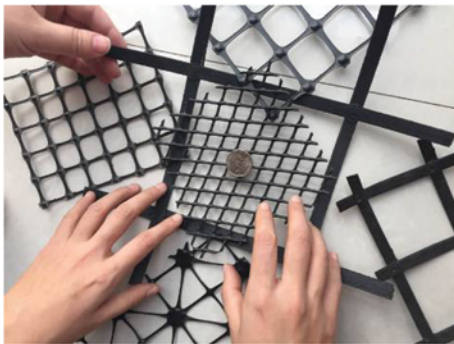

Various geogrids

Application

- Where layer separation is needed
- Retrofit
- Locations of chronic soft spots, rutting, and pothole formation
- New road
- Subsurface and surface water flows

Construction

- Follow the manufacturer's advice for handling and installation. The effectiveness of the material could be severely reduced if it is torn or punctured during placement; not properly overlapped, anchored, or attached; or otherwise installed incorrectly.
- Avoid prolonged direct sunlight during storage, stack horizontally or vertically--no more than 5 rolls high, and avoid contact with sharp or other detrimental materials.
- During installation, make sure subgrade is fit for installation (clear of debris, compacted, flat, etc).
- Add fill or cover materials evenly across surface. Don't use motor grader since front wheels are in front of blade.

Maintenance

- If installed correctly, there is relatively little maintenance
- Check for exposure of material along road edges and on surface. Add more cover material as needed.
- Watch for erosion in areas where materials may be separating due to poor installation.



Geogrid installed between subgrade and surface layer to strengthen soil and better distribute loads.



When exposed, add a thin layer of surface aggregate.



Geocells used to confine gravel at a wet area crossing on Forest Service roadway.

Geotextiles

(Graphics from www.canaannh.org/departments/highway/index.html)

Effects of shear forces on aggregate migration

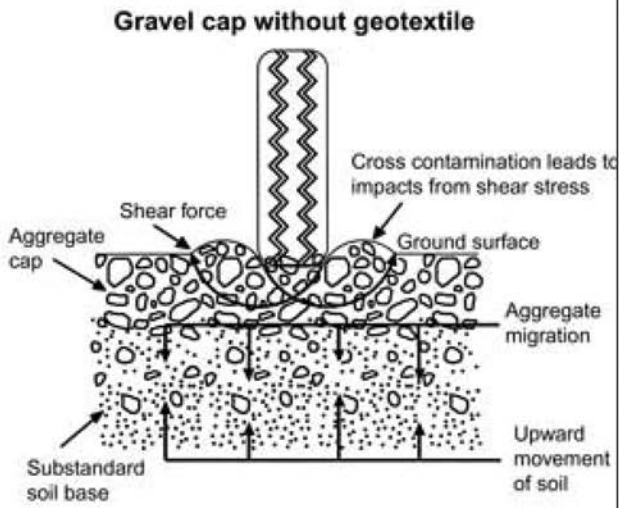

Gravel cap with geotextile

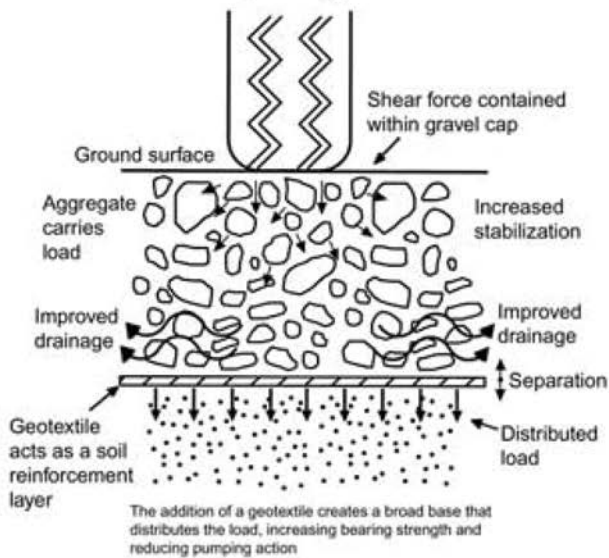

Effects on pumping forces

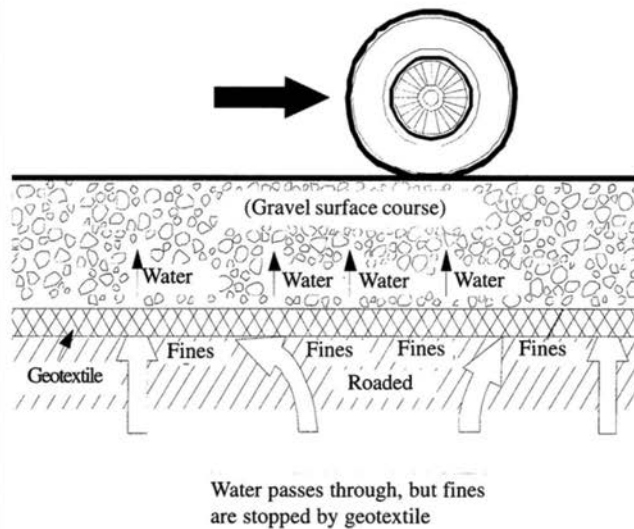
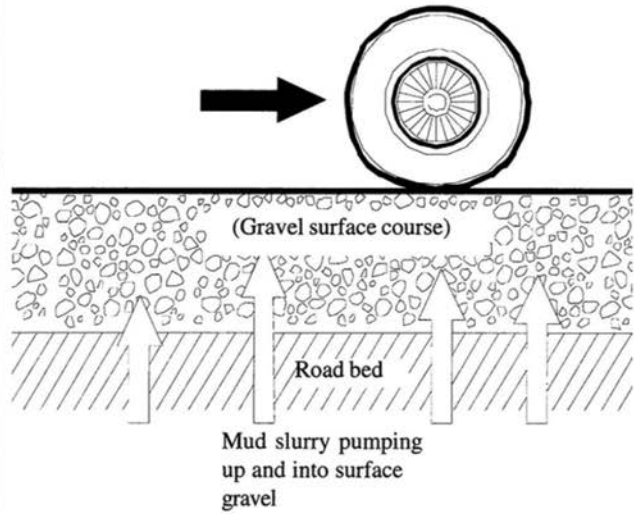

Step 1. Compaction of native subgrade.



Step 2. Installation of overlapping geotextile fabric.



Step 3. Covering geotextile with base course.

Soil/Aggregate Stabilizers

Description

There are a wide range of organic and synthetic compounds (e.g., lignin derivatives, chlorides, resins, acrylic polymers, enzymes, and petroleum-based products) used to minimize dust (loss of fines) and improve the binding and hardening of soil/aggregate road layers. Given the lack of information on how these compounds may affect aquatic ecosystems—even those labeled as non-toxic or environmentally-safe—their use is cautioned in coral watersheds. Petroleum-based products should never be used; however, cement and other pozzolanic compounds (e.g., lime or fly ash) are viable alternatives. Cement-treated base (CTB) is a general term that applies to a mixture of native soils and/or aggregates with small amounts of Portland cement and water that hardens after compaction to form a strong, durable, water-resistant base course. A thinner cement-stabilized section can reduce subgrade failures more than a thicker layer of untreated aggregate base, which can extend road surface life. CTB is a relatively cost-effective alternative to paving.



Application

- | | |
|---|--|
| <input checked="" type="checkbox"/> Strategic, short sections of road | <input checked="" type="checkbox"/> Segments requiring frequent resurfacing where drainage control options are limited |
| <input checked="" type="checkbox"/> Steep sections | <input checked="" type="checkbox"/> Low spots or water crossings |

Design

- The soil and aggregate materials for use in CTB may consist of any combination of gravel, stone, sand, silt, and clay; miscellaneous material such as caliche, scoria, slag, sandshell, cinders, and ash; and recycled, crushed stone or gravel. Well-graded blends with a nominal maximum size <3 inches are recommended.
- Simple lab tests can establish the proper cement content, compaction, and water requirements of the soil material to be used.
- Nearly all soils can be stabilized, except where there is high organic content or clay content. Sandy, gravelly soils with 10-35% silt and clay are ideal. Percent cement content by weight can range anywhere from 2-8%, but will be higher if silt and clay content is high. Higher cement ratios can lead to cracking. Lime can be used instead as a drying agent or as a soil modifier to reduce plasticity of clayey soils.
- Soil moisture should be <10%. If the mix is too dry, there is not enough moisture available to lubricate the particles into a denser formation. If the mix is too wet, the excess moisture pushes the particles apart.
- Depth of treatment can range from 6-12 inches, should be on high end for higher volume roads.
- Best if used below a compacted wearing course, but if used as surfacing, additional concrete ratio would produce a stronger, more durable wear surface.
- See references for more information before using CTB.

Construction

- If not constructed properly, it will not perform well. This must be tested in the field to best determine what works best for your soils and available equipment.
- Prepare subgrade. Soil/aggregate should be distributed over an accurately graded, well-compacted subgrade in an even layer.
- Cement is most commonly applied dry, but can also be applied in a slurry form. Procedures for mixing will depend on equipment (e.g. mixer vs rototiller).
- A thorough mixture of soil/aggregate, cement, and water must be obtained. The soil/aggregate and cement must be sufficiently blended when water contacts the mixture to prevent the formation of cement balls. The number of mixing passes depends on the type of mixer, the soil/aggregate and its moisture content, and on mixer speed. Depending on soil moisture content, you may need to pre-wet soil to facilitate mixing.

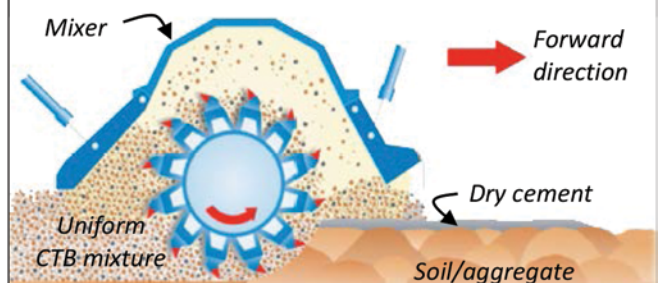

Aggregate gradation band for minimum cement requirements (Halsted et al., 2008)

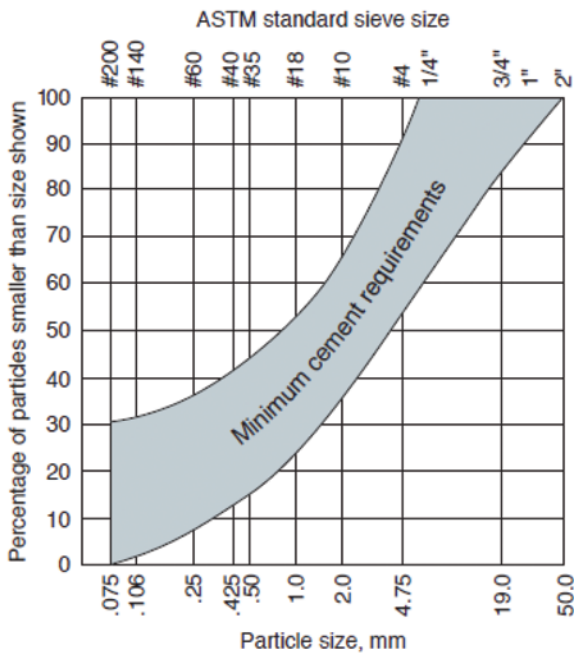

Cement hydration produces calcium-silicate-hydrate (CSH) and calcium-aluminum-hydrate (CAH), which act as the “glue”. Hydrated cement also forms calcium hydroxide, or $\text{Ca}(\text{OH})_2$, which undergoes secondary reaction that creates more CSH/CAH overtime.

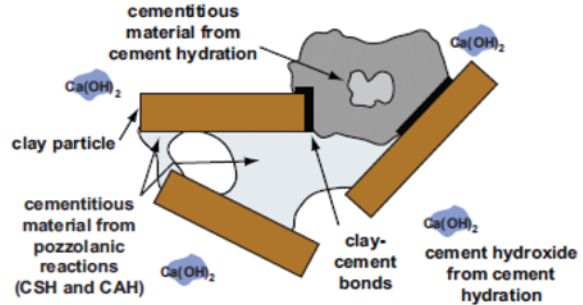

Construction (cont.)

- Uniformity of the mix can be checked by digging trenches or borings to inspect color and texture; a streaked appearance indicates insufficient mixing.
- Compact and regrade to shape before final compaction.
- Must be completed in small batches within 30 min to 2 hours from wetting to avoid hardening & evaporation.
- Curing up to 7 days (keep traffic off) depending on surface finishing plans.
- Do not use to fix potholes or other localized surface deformities.

References

- Federal Highway Administration standard specifications FP-03, Section 302.
- Halsted, et al. 2008. Guide to Cement Treated Base and Guide to Cement Modified Soils.
- Portland Cement Association. Soil-Cement Laboratory Handbook, EB052



1 Spread dry cement

2 Mix and grade

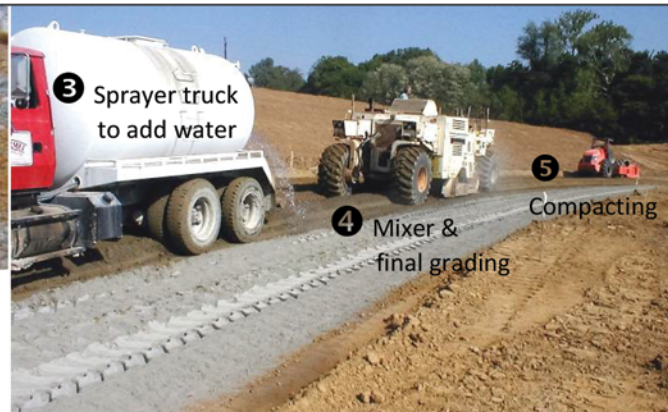

3 Sprayer truck to add water

4 Mixer & final grading

5 Compacting

The process of creating CTB will be determined based on the equipment available and materials you are working with. Basic steps include spreading, uniform mixing, proper grading, hydrating, and compacting.



Bags of cement distributed and spread by hand and rake/hand spreader.



Multiple passes with tractor pulling tiller or disks can be used to mix soil/ aggregate with cement.



Use of a water truck to wet mixture before final grading and compaction.



Slope Stabilization

Description

Slope stabilization is the prevention of erosion of road cut and fill slopes through shaping, vegetation, or structural fortification to prevent erosion or failure of any slope. Road bank erosion can disrupt road drainage, impact water quality, create safety hazards, and increase road maintenance costs. Slope failure can be caused by overbank drainage, heavy rainfall, and seepage, a soil movement. The stabilization techniques outlined here are appropriate for immediate protection of road banks against surface erosion and small gully repair. Large-scale slope projects and landslide prevention should be referred to geotechnical engineers.



Design

Design will depend on the type of stabilization approach selected. There are a wide variety of techniques to choose from. Selection will depend on what materials are readily available, cost, aesthetics, and steepness of the slope in question. Most slopes would benefit from a combination of grading, vegetation, and “hard” structures.

- Proper grading or regrading of slopes to a maximum 2:1 slope can often stabilize banks without the use of structures.
- When naturalizing slopes with vegetation, use native species and consider root structure (e.g., woody plants & vetiver with extensive roots to hold soils). Combine with surface grading techniques on steep slopes such as terracing or bank benches to break slope and provide planting shelves.
- Retaining walls and revetments may be required where space limitations necessitate vertical slopes. There are a number of bioengineering alternatives that incorporate plants into traditional “hard” structures.

Application

- | | |
|---|--|
| <input checked="" type="checkbox"/> Retrofit | <input checked="" type="checkbox"/> Unconsolidated cut slopes |
| <input checked="" type="checkbox"/> New roads | <input checked="" type="checkbox"/> Fill slopes subject to erosion |
| | <input checked="" type="checkbox"/> Not for large-scale landslide protection |

Construction

- Installation procedures will depend on the specific stabilization method selected (see below). Follow manufacturer’s installation instructions for geogrids, hydroseeding, and erosion control blankets.
- During construction all slopes should be temporarily (if not permanently) stabilized.
- We tend to create smooth, uniform slopes, but we should embrace every opportunity to incorporate features to roughen slopes.

Maintenance

- Different methods will necessitate different maintenance needs.
- Once vegetative is established or structures in place, then relatively little maintenance anticipated if designed and installed properly.
- Repair any slope failures and replant as needed.



Rows of vetiver grass recently planted along road outslope. Hydroseeding is visible between rows to help hold exposed soil in place while vetiver establishes.



Example of a stone revetment used to stabilize road banks. Gabion baskets are also popular. Consider options that combine both rock with native vegetation.



Example of geosynthetic soil containment cells used on road outslope to hold soil in place for subsequent planting.

Naturalizing the Bank Shape through Grading

(graphics from VT Better Back Roads Manual)

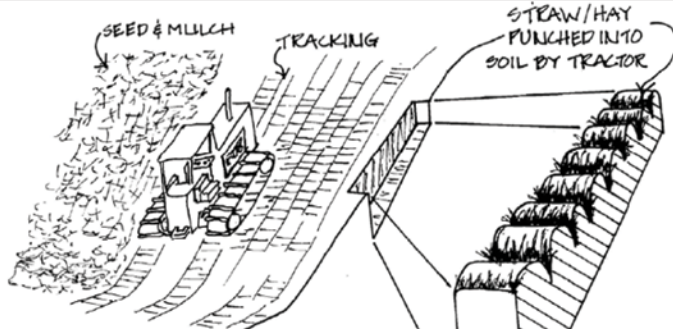

SURFACE ROUGHENING/TRACKING

During road construction activities, all slopes composed of loose, erodible material should be stabilized as soon as possible. At a minimum, slopes should be tracked to prevent rills and gullies, and temporarily seeded or mulched to increase surface roughness. This technique is a basic erosion and sediment control requirement for temporary management of construction sites.

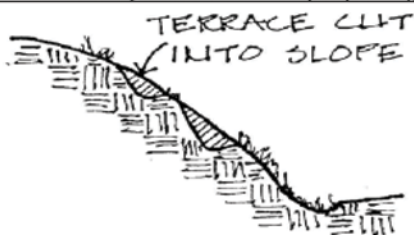

TERRACING

Construct benches on excessively steep and long slopes to provide areas to intercept and divert water or to serve as planting shelves. Often used in combination with hydroseeding and diversion ditches. Backslope terraces inwards toward the slope to intercept water and prevent erosion.

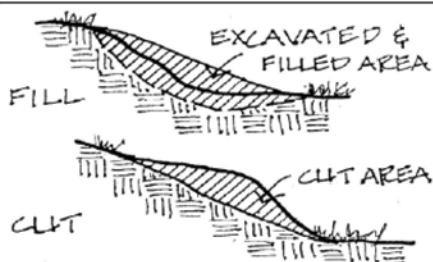

CUT AND/OR FILL

Where slopes are too steep, additional soil can be removed (or fill can be added) to the bank to create the desired 2:1 or flatter slope. This technique can be used to replace less stable soils with more adequate material or to incorporate stabilizing geotextiles during the process of regrading. Sometimes better soils are required in order to promote plant growth.



NOTCHING & KEYING

Where fill is placed on a slope, the cutting of "V" or trapezoid shaped contours into the existing ground can help improve slope stabilization by giving the fill material a footing into the native subgrade. Geosynthetics and structural anchors may be needed on steeper slopes.

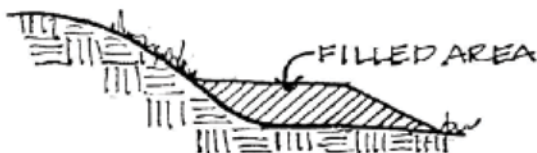

COUNTERWEIGHT

Where space is available, a one level bench and slope can be added next to a steep failing bank to hold the bank up and prevent continued sliding. Makes for a good planting bench.



Tracking upslope to create horizontal cleat depressions across slope surface.



Creating benches on an almost vertical slope.



Large scale terracing prior to vegetative planting.

Slope Stabilization with Vegetation



SEEDING

An efficient and inexpensive method to stabilize a bank by slowing the movement of water, allowing more water to seep into the ground.

- Seed within 14 days of disturbance.
- Clear debris from slope surface in advance.
- Apply native seeds and grasses uniformly with seed spreader or hydroseeder.
- Check with regional NRCS on appropriate grass species and other seed mixes.
- Hydroseeding uses a water truck with a mounted sprayer that broadcasts a mixture of seed, mulch, and tackifier. Wood mulch preferred over paper to retain soil moisture.
- Plant at beginning of rainy season.

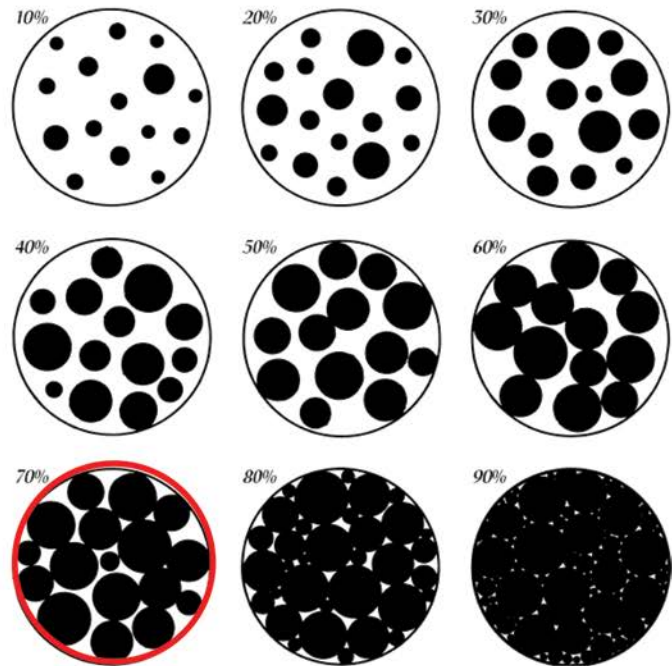

Visual Representation of % Coverage
(from Cornell University)

A seeded area can be considered successfully vegetated when the established grass coverage in multiple spots is at least 70% (black dots indicate vegetation, white voids is bare soil).



Hydroseeding can help with grass establishment, particularly during the dry season. Try to smooth slope and eliminate clumps and rills prior to seeding to improve surface area contact during seeding, eliminate erosion pathways, and support vegetative establishment.

Use appropriate seed mixes, tackifier, and paper or wood mulch (wood mulch is better). Fertilizer may be necessary.

VETIVER

A perennial bunch grass with massive root system (2 ft on each side of the plant and >8 ft deep) that is great for stabilizing slopes, phytoremediation of heavy metals and PAHs in the soil, as well as wastewater treatment. It grows on a wide variety of soils from sands to clay with a pH range from 4 to 7.5. Prefers neutral to slightly alkaline soils. It tolerates saline soils.

- Use only sterile genotypes, such as “Sunshine” and “Sierra” varieties in the Pacific and Caribbean, respectively.
- Harvest and divide clumps with shovel or pick-axe, keeping as much of root as possible. Prune to 10-20 in.
- Store in fresh, humid location until planting.
- Mark contour lines in the field and dig furrow.
- Plant clumps an equal distance from each other 4-6 inches apart. DO NOT LEAVE OPEN SPACES, which might allow gullies to form. Plant a double row if high water flows anticipated.
- Once established, monitor the barrier and replant vetiver if needed. Keep it pruned to about 20 inches tall to encourage more root growth.
- See NRCS. 2015. Fact sheet: *Control Soil Erosion, Maintain and Improve Water Quality with Vetiver Barriers*

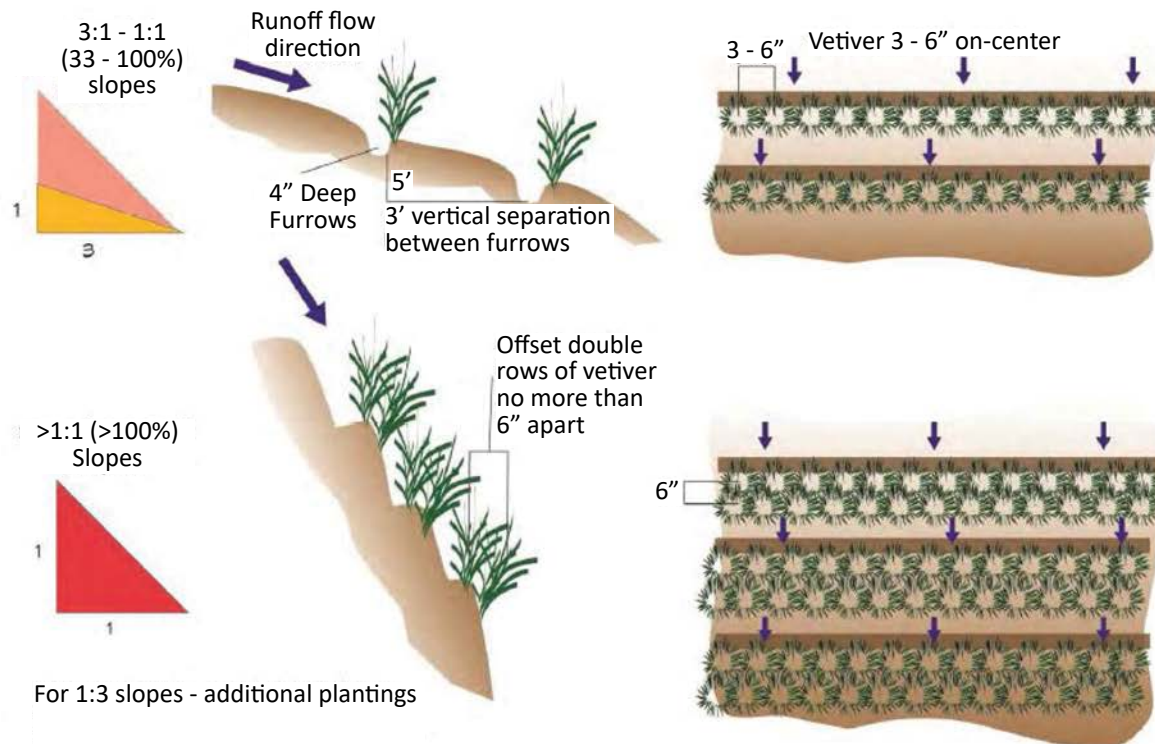

Example details from Coral Bay Community Council (2017) provides guidance on vetiver installation techniques for different slopes. For slopes flatter than 33%, vertical spacing between rows can increase to 6".

Structural Stabilization Alternatives *(Graphics: VT Better Backroads Manual)*

GEOGRIDS

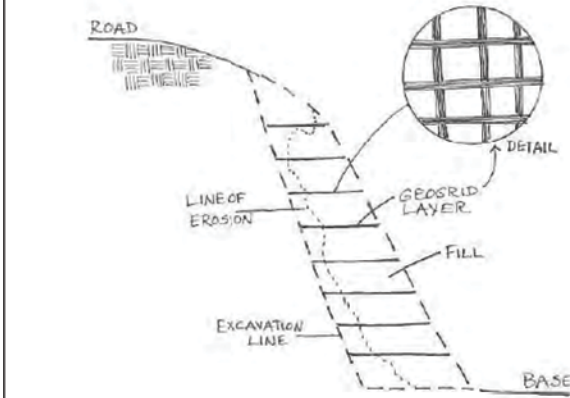

Extremely durable geosynthetics with high tensile strengths that are ideal for stabilization on slopes steeper than 2:1.

- Can be used as an alternative to riprap or a concrete retaining wall.
- Can be planted over with vegetation for additional strength and aesthetics.
- Resist degradation by water and chemicals normally found in soils.
- Check with product manufacturer for specific installation details.

EROSION CONTROL BLANKET

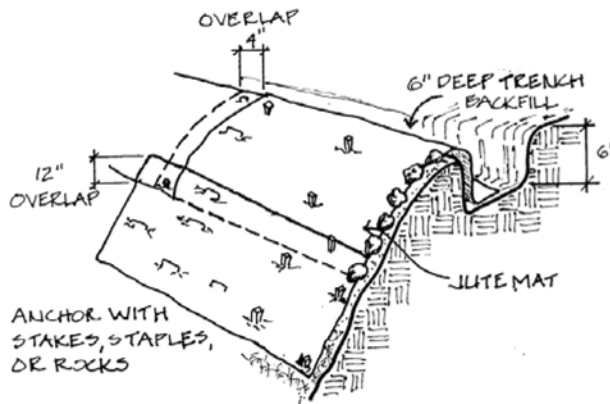

Biodegradable netting or rolled matting made of jut, coconut fibers, synthetics, or other material laid on surface to hold soil in place and to help vegetation establish. Use on cut/fill slopes >15%. Select product based on slope, flow velocities, durability, and manufacturer's recommendations.

- Spread over seeded and mulched areas.
- Bury up slope end of each section in a 6-inch vertical slot/anchor trench, backfill and compact.
- Overlap each up slope section with 12 inches of mat; side-by-side sections by 4 inches.
- Securely anchor with stakes and/or staples.

VEGETATED ROCK WALL

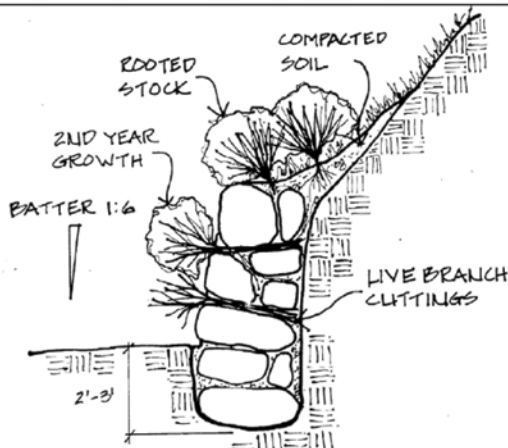

A combination of rocks and live branches, as used in brush layering.

- Provide a well-drained base for the wall and weep holes (if needed).
- Excavate a minimum amount of slope behind wall.
- Place rocks with long axis slanting inward toward the slope.
- Backfill between each layer of rocks and place live branch cuttings on backfill.
- Cover with soil and compact.
- Use at the base of a slope where a low wall, not higher than 5 feet is required.



Geogrid layers stacked on a slope.



Coir fiber erosion control mat on hydroseeded slope.

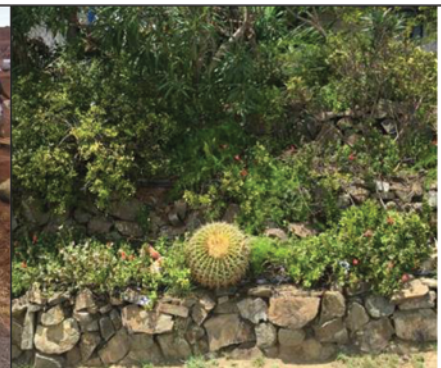

Use appropriate vegetation for planting in a rock wall.

Biotechnical installations are good for very steep slopes - 1:1 (100%) or more.

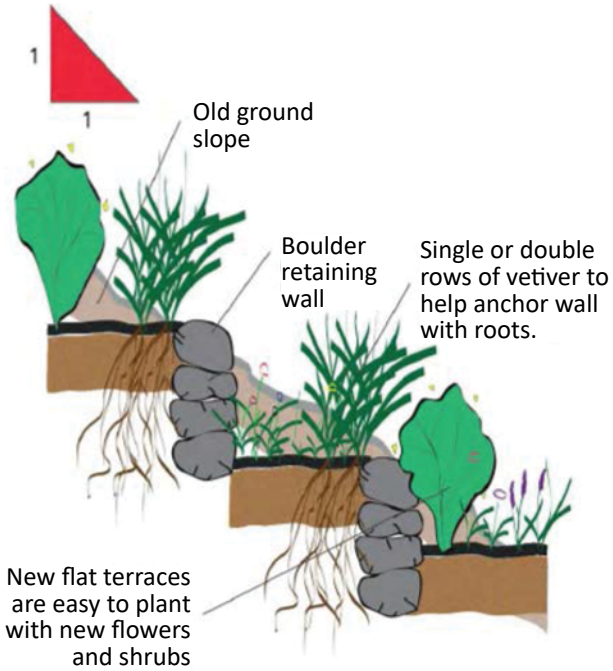

Stagger vetiver plants for maximum root development and runoff control

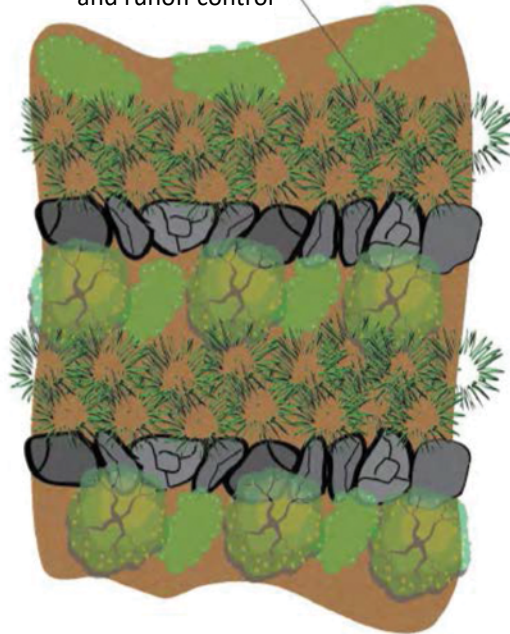

Combination of terracing, retaining walls, and vetiver to stabilize a slope (Coral Bay Community Council, 2017).

Suitable for All Slopes

Stakes should be inserted up to 6" and secured on steeper slopes with re-bar.

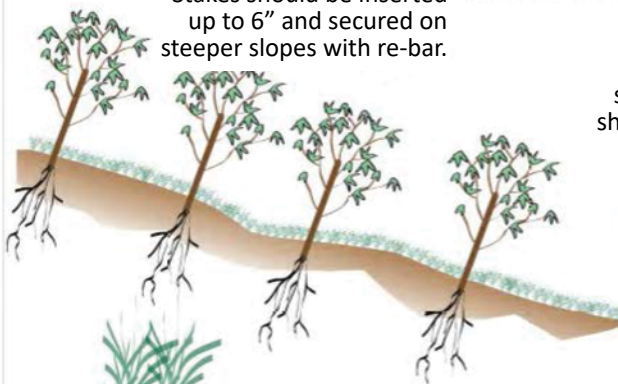

Space stakes according to species. Species with spread should be spaced farther apart.

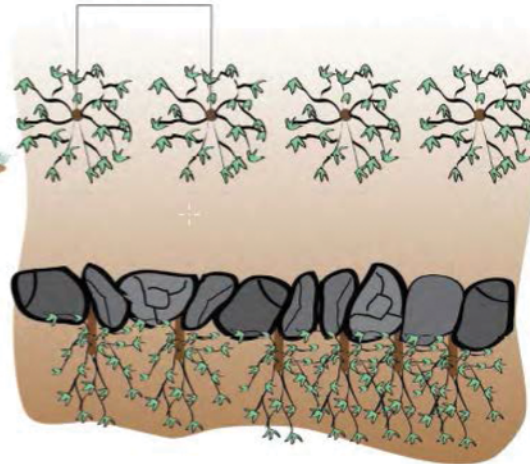

Stakes can be inserted in soil between dry-stacked boulders in retaining walls.

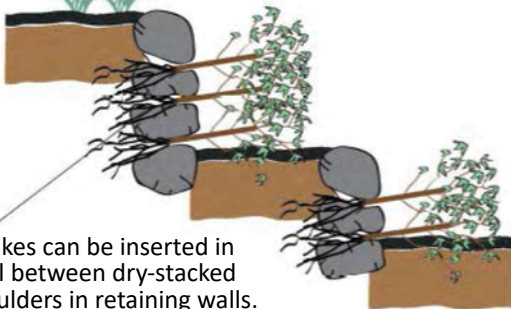

Coral Bay Community Council (2017) describes methods for live staking (length and diameter of cutting, cutting storage time, planting depth, etc.). Types of plant species suitable to the US Virgin Islands recommended include: *Ficus citrifolia*-wild fig or wild banyan tree, *Bursera simaruba*-turpentine tree, and *Plumeria alba*-wild frangipani.



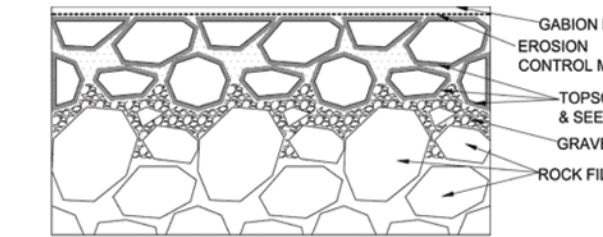
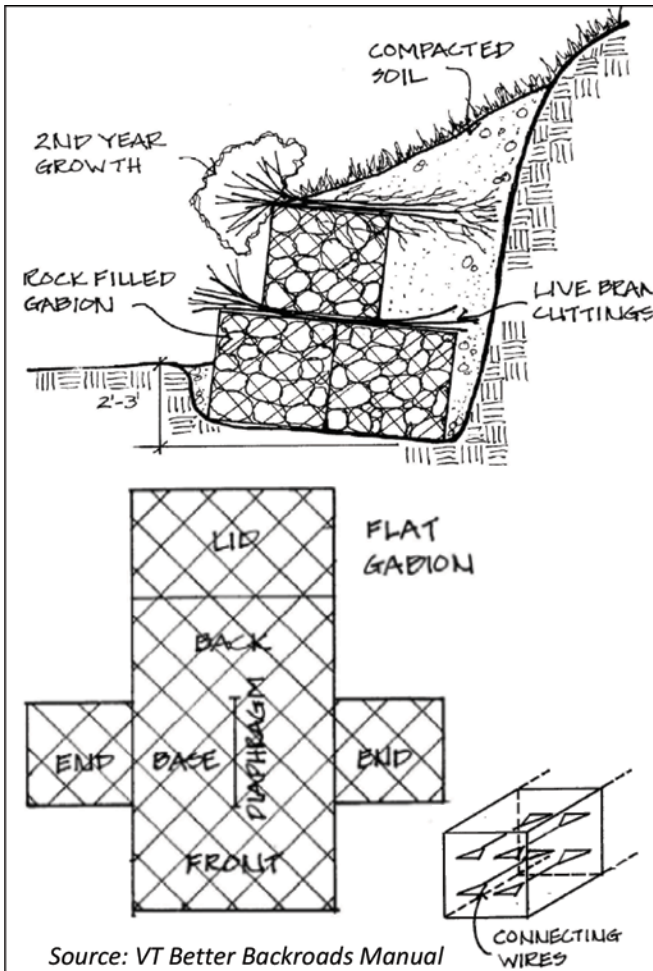

GABION SECTION

(Source: Terraqua.com)



VEGETATED GABION BASKETS

Wire mesh rectangular boxes filled with locally-available rock, bricks, or other recycled materials and used as a retaining wall. Great for driveway cuts and at the base of a slope where a low wall (< 5 feet) is required.

- Wire baskets and connecting wires are shipped flat for onsite assembly.
- Gabions are permeable allowing water to seep through and aiding in the removal of sediments.
- Gabions can be stacked or terraced (tilted inward towards slope). Backfill between each layer of gabions. Cover with soil and compact.
- Gabions can be combined with woody and non-woody vegetation for aesthetics and stabilization, where live branches/roots can be used to bind gabions into the slope. Place live cuttings between each layer and extend into back fill.
- Top soil layer can be used in baskets to help establish plants. A layer of soil can also be installed on top of basket. Use filter fabric, erosion control matting, and/or smaller gravel layers between soil and gabions to prevent soil washout.
- Relatively no maintenance needed once installed. May have to water until plants become established. May loose topsoil if fabric is punctured or improperly installed.



References

- Berkshire Regional Planning Commission. 2001. The Massachusetts Unpaved Roads BMP Manual: A Guidebook on How to Improve Water Quality While Addressing Common Problems. www.mass.gov/eea/docs/dep/water/resources/a-thru-m/dirtroad.pdf
- Center for Dirt and Gravel Road Studies. 2012. Environmentally Sensitive Maintenance Practices for Dirt and Gravel Roads. Penn State University. www.fs.fed.us/eng/php/library_card.php?p_num=1177%201802P
- Center for Dirt and Gravel Road Studies. Technical and Informational Bulletins www.dirtandgravel.psu.edu/general-resources/informational-and-technical-bulletins
- Center for Dirt and Gravel Road Studies. 2017. Driving Surface Aggregate Handbook. Penn State University. www.dirtandgravel.psu.edu/general-resources/driving-surface-aggregate-dsa
- Coral Bay Community Council. 2017. Vegetation for Erosion Control—A Manual for Residents. <http://coralbaycommunitycouncil.org/landscaping-sediment-reduction/>
- FAO Road Construction Techniques www.fao.org/docrep/006/T0099E/T0099e06.htm
- Halsted, G., W. Adaska, W. McConnell. 2008. Guide to Cement-Modified Soil. (CMS), EB242 Portland Cement Association, Skokie, IL, 20 pp.
- Halsted, G., D. Luhr, W. Adaska. 2006. Guide to Cement-Treated Base (CTB), EB236 Portland Cement Association, Skokie, IL, 20pp.
- NRCS. 2015. Fact sheet: Control Soil Erosion, Maintain, and Improve Water Quality with Vetiver Barriers.
- Ramos-Scharrón CE, MacDonald LH. 2005. Measurement and prediction of sediment production from unpaved roads, St. John, USVI. *Earth Surface Processes and Landforms* 30: 1283-1304.
- Texas A&M Forest Service. 2013 <http://tfswater.blogspot.com/search/label/Broad-Based%20Dip>
- Transportation Information Center. 2002. Pavement Surface Evaluating and Rating System: Gravel PASER Manual. University of Wisconsin.
- USDA Forest Service. 2008. Soil and Water Road-Condition Index-Field Guide.
- USDOT Federal Highway Administration, US Department of Transportation. 2015 Gravel Road Construction and Maintenance Guide. www.fhwa.dot.gov/construction/pubs/ots15002.pdf
- Vermont Better Backroads Manual, 2009. <http://vtrans.vermont.gov/sites/aot/files/highway/2009%20Better%20Backroads%20Manual.pdf>.
- VT Better Backroads Erosion Inventory Assessment Manual, 2015. <https://anrmaps.vermont.gov/websites/pdfs/Road%20Erosion%20Risk%20Manual.pdf>
- VT Department of Environmental Conservation. 2016. Municipal Roads General Permit. <http://dec.vermont.gov/watershed/stormwater/permit-information-applications-fees/municipal-roads-program>



Acknowledgements:

Much of the information provided here was crafted from original guidance developed by the VT Better Roads Program and the Penn State Center for Dirt and Gravel Roads Studies and adapted to the islands. Thank you to the many individuals who worked with us over the past decade on taming unpaved roads. These experiences have informed our understanding of road behavior and provided a wide range of opportunities to experiment with different practices in different island settings. Most of the local examples included here come from restoration work on Culebra, PR, St. John, USVI, and Saipan, CNMI. The authors want to specifically acknowledge Lisa Vandiver and Rob Ferguson with NOAA for their editorial and graphic contributions, as well as photos and resources provided by the Coral Bay Community Council, Derek Chambers and the CNMI Bureau of Environmental and Coastal Quality, Dave Hirschman, Carlos Ramos-Scharron, and other island practitioners.



Potholes and polyps
sculpted by flowing waters—
at odds over dirt.
-ACK

Photo: Mohamed Sarim